

PURCHASE AGREEMENT

Order #: 20043
Client Name: Martin Schacht

Status: Version: Created: Revised:
Order 13.9.0 02/17/2016 03/24/2016



SALES CONTACT:

Scott Rausch
scott@beckercustomtrailers.com
702.802.1564 (Work)

BECKER CUSTOM TRAILERS

6963 Speedway Blvd.
Las Vegas, NV 89115
800-595-7729
beckercustomtrailers.com

CONTACT INFORMATION

NOTES

MODEL INFO

Configured Model #: QSTAB8520+0-2T3.5K
2016 Quest Aluminum Trailer
8.5'W x 20'L x 6.5'H, (2) 3500# Torsion Axle(s)
VIN: 5JXAE2427GE203970
Warranty: 5 YR STR, 3 YR LTD, 1 YR ELEC WARRANTY

COLOR: Polar White (Standard)

REAR COLOR: None

COLOR - CABINETS: NONE

SPECIFICATIONS

Part Name	Qty	UOM	Total Ext. \$	Ref.
BASE MODEL				
QSTAB8520+0-2T3.5K	1	ea	\$11,981	STD
<ul style="list-style-type: none"> Modification: Delete Roof Vent 				
Limited Options Discount	1		(\$503)	OPT
AXLE - 3500# - TORSION - EZ LUBE HUBS - ELECTRIC BRAKES	2	ea		STD
<ul style="list-style-type: none"> GROUND CLEARANCE: STANDARD (APPROX. 14.25" - NO LOAD) 				
AXLE SPACING - SPREAD AXLE	1	ea		STD
ALL TUBE CONSTRUCTION	20	ft		STD
COUPLER - A-FRAME - 2-5/16" - 10,000#	1	ea		STD
CROSS MEMBERS - FLOOR - 16" O/C	20	ft		STD
CROSS MEMBERS - ROOF - 16" O/C - 1" X 3"	20	ft		STD
CROSS MEMBERS - WALL - CS - 16" O/C - 1" X 1.5"	20	ft		STD
CROSS MEMBERS - WALL - RS - 16" O/C - 1" X 1.5"	20	ft		STD
FRAME - 5"	20	ft		STD
FRAME - FULL PERIMETER - ALUMINUM	20	ft		STD
FRAME PROTECTION - SKID PLATES	1	pr		STD
FRONT DESIGN - FLAT	1	ea		STD
JACK - TONGUE - TOP WIND - 5000# - ZINC	1	ea		STD
TONGUE - STANDARD	1	ea		STD
TRUCK PLUG - 7 WAY	1	ea		STD
EXTERIOR ALUMINUM - STANDARD COLOR	20	ft		STD
<ul style="list-style-type: none"> Color: Polar White (Standard) 				

EXTERIOR FASTENER - SCREWLESS	20 ft	STD
EXTERIOR ALUMINUM THICKNESS - .030	20 ft	STD
FENDERETTES - AL	4 ea	STD
GRAVEL GUARD - ATP - 24" - WITH J RAIL	1 ea	STD
ROOF - ONE PIECE - ALUMINUM	20 ft	STD
INTERIOR HEIGHT - 6.5'	20 ft	STD
FLOORING - ADVANTECH - 3/4"	20 ft	STD
WHEEL BOX - SMOOTH AL	2 ea	STD
LIGHT - CLEARANCE - LED - 12V - AMBER - LOWER	2 ea	STD
LIGHT - CLEARANCE - LED - 12V - AMBER - UPPER	4 ea	STD
LIGHT - CLEARANCE - LED - 12V - RED - LOWER	2 ea	STD
LIGHT - CLEARANCE - LED - 12V - RED - UPPER	7 ea	STD
LIGHT - TAILLIGHT - SLIMLINE - LED - 12V - RED	1 pr	STD
PACKAGES		
PACKAGE - CAR HAULER	1 ea	(\$82) OPT
FLOOR DESIGN - BEAVERTAIL	1 ea	\$184 PKG
D-RINGS - 5000# - RECESSED	4 ea	\$144 PKG
DOOR - REAR RAMP - PREMIUM - CONTINUOUS ALUMINUM HINGE - 4000# RATED	1 ea	\$632 PKG
RAMP DOOR EXTERIOR - REAR - COLOR MATCHED	1 ea	PKG
TRANSITION FLAP - ADVANTECH - 3/4" - 16"L	1 ea	PKG
RAMP DOOR FLOORING - REAR - ADVANTECH - 3/4"	1 ea	PKG
DOOR HARDWARE - LATCH - BAR LOCK - ALUMINUM	1 pr	PKG
HASP - STAINLESS STEEL - FOR CAM BARS/BAR LOCKS ON RAMP DOOR	1 pr	OPT
PACKAGE - ELECTRICAL #1	1 ea	(\$80) OPT
POWER INLET - MOTORBASE - 15A	1 ea	\$69 PKG
RECEPT - INTERIOR - 120V - 15A	1 ea	\$44 PKG
<ul style="list-style-type: none"> GFCI PROTECTED USED FOR: 55 AMP CONVERTER 		
BATTERY - 12V AGM (930 CA, 775 CCA)	1 ea	No Charge
CONVERTER - 55 AMP WITH BATTERY CHARGER	1 ea	\$165 PKG
OPTIONS		
JACK - STABILIZER - SCISSOR - 24" - 5000#	1 pr	\$322 OPT
<ul style="list-style-type: none"> Location: REAR 		
TIRE/WHEEL - ST235/80R16/LRE - RADIAL ON ALUMINUM - W/STAINLESS STEEL LUGNUTS	4 ea	\$732 OPT
SPARE TIRE/WHEEL - ST235/80R16/LRE - RADIAL ON ALUMINUM	1 ea	\$398 OPT
SPARE TIRE MOUNT - INTERIOR WALL	1 ea	\$72 OPT
TONGUE COVER - ATP	1 ea	\$100 OPT
LOGO PROGRAM - BECKER CUSTOM TRAILERS	1 ea	STD
TRIM - VERTICALS - FRONT & TOP RADIUS - STAINLESS STEEL WITH CAST CORNERS - POLISHED	1 ea	\$220 OPT
TRIM - SPOILER - REAR - COLOR MATCHED W/ 3 LED LIGHTS	1 ea	\$569 OPT
TRIM - VERTICALS - REAR - COLOR MATCHED	1 ea	OPT
TRIM - RUB RAIL - UPPER - ALUMINUM - 4"	20 ft	\$80 OPT
TRIM - RUB RAIL - LOWER - ALUMINUM - 7"	20 ft	\$160 OPT
VENT SYSTEM - TWO WAY - SALEM	1 pr	\$173 OPT
DOOR - ENTRANCE - 405 SERIES - 48" X 72" - FLUSH LOCK	1 ea	\$373 OPT
<ul style="list-style-type: none"> RIGHT HINGE 		
DOOR - ESCAPE - PREMIUM - 88" X 66" - TOP HINGE - FLUSH LOCK - REMOVABLE WHEEL WELL	1 ea	\$1,423 OPT
<ul style="list-style-type: none"> ALUMINUM STEP ONE PIECE REMOVABLE INTERIOR WHEEL WELL EXTERIOR FENDERETTES INTEGRATED INTO DOOR 		

- (2) 140# GAS SHOCKS
- (2) PROP RODS

INTERIOR CEILING - WHITE VINYL	20 ft	\$300 OPT
<ul style="list-style-type: none"> • Cove Color: Dark Gray Metallic • Spring Box Color: Dark Gray Metallic 		
INTERIOR WALLS - WHITE VINYL WITH H-MOLDING	20 ft	\$280 OPT
BATTERY BOX - IN-FLOOR - SINGLE	1 ea	\$399 OPT
LIGHT - DOME - LED - 12V - RECESSED	3 ea	\$120 OPT
SWITCH - WALL - 12V	1 ea	\$30 OPT
<ul style="list-style-type: none"> • USED FOR: LED LIGHTS IN REAR SPOILER 		

Grand Total \$18,566.00
F.O.B.-Las Vegas

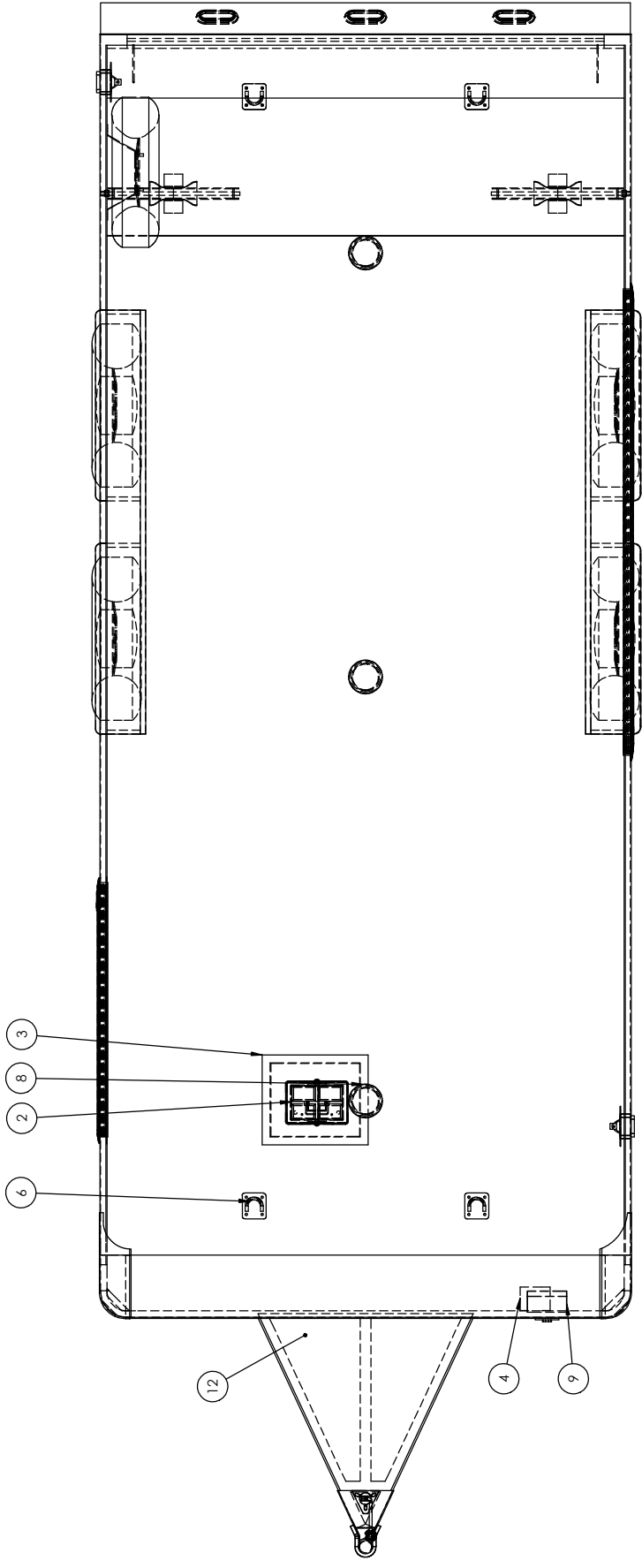

ATTENTION:
 ATC IS NOT RESPONSIBLE FOR CLEARANCE OF VEHICLE
 UNTIL CUSTOMER/DEALER COMPLETES VEHICLE CLEARANCE
 FORM AND IS VERIFIED BY ATC ENGINEERING DEPARTMENT.

**DIMENSIONS ARE NOMINAL. STRUCTURAL MEMBERS OFTEN DICTATE
 WHERE INTERIOR FEATURES CAN BE PLACED. CONSEQUENTLY, SOME
 DIMENSIONED ITEMS RETAIN A +/- 2" TOLERANCE. CRITICAL (BUBBLED)
 DIMENSIONS WILL RETAIN A TOLERANCE OF +/- 1/4".**

REV.	DESCRIPTION	DATE	DONE BY
A	REMOVED BATT. SPARE BOX. V NOSE ADDED SPARE MOUNT AND CAST CORNERS	3/8/2016	GOM
B	ADDED SPARE AND DOME LIGHTS	3/11/2016	GOM
C	CHANGED JACK TO TOP WIND	3/16/2016	GOM
D	CHANGED DOOR TO 48 AND FIXED HEADER *	3/16/2016	GOM
E	ADDED SPARE BOX. SCISSOR JACKS, ELEC PKG 1, 16 RIMS	3/23/2016	GOM
F	SPARE BOX TO BATT BOX *	3/24/2016	GOM

**ALL LOCATIONS ARE NOMINAL UNLESS CRITICAL
 DIMENSIONS ARE SPECIFICALLY NOTED**

PROPRIETARY AND CONFIDENTIAL:
 THE INFORMATION CONTAINED IN THIS DRAWING IS THE SOLE
 PROPERTY OF THE ALUMINUM TRAILER COMPANY. ANY
 REPRODUCTION IN PART OR AS A WHOLE WITHOUT THE WRITTEN
 PERMISSION OF THE ALUMINUM TRAILER COMPANY IS PROHIBITED.



FILE NAME	8520+0-2T ALUMINUM
DATE	03/03/16
VIN/PART #	203970
REV.	F
FILE NAME	DW-BP 8524-Becker-Schacht-203970
SCALE	1:16
DATE PRINTED	3/24/2016
SHEET	1 OF 6

ITEM NO	PART NO	FILE NAME	DESCRIPTION	QTY
1		AXLE, TORSION	3500# (94-78) ODEG	2
2	68749	BATTERY	AGM, 775 CCA	1
3		BOX, IN FLOOR	1 Battery	1
4	12451	CONVERTER, 12VDC	55 AMP	1
5		COUPLER, 10K		1
6	13413	D-RING	5000#	4
7	18531	JACK, TOP WIND	5,000#TOP WIND	1
8	33515	LIGHT, DOME	SURFACE MOUNT	3
9		MOTORBASE	15 AMP	1
10	11023	SCISSOR JACKS	24" 5000#	2
11		TIRES	235/80/16	4
12		TONGUE COVER		1
13	14626	VENT, SALEM		2
14	40249	WHEEL, WELL	7.5" x 13" x 80"	2

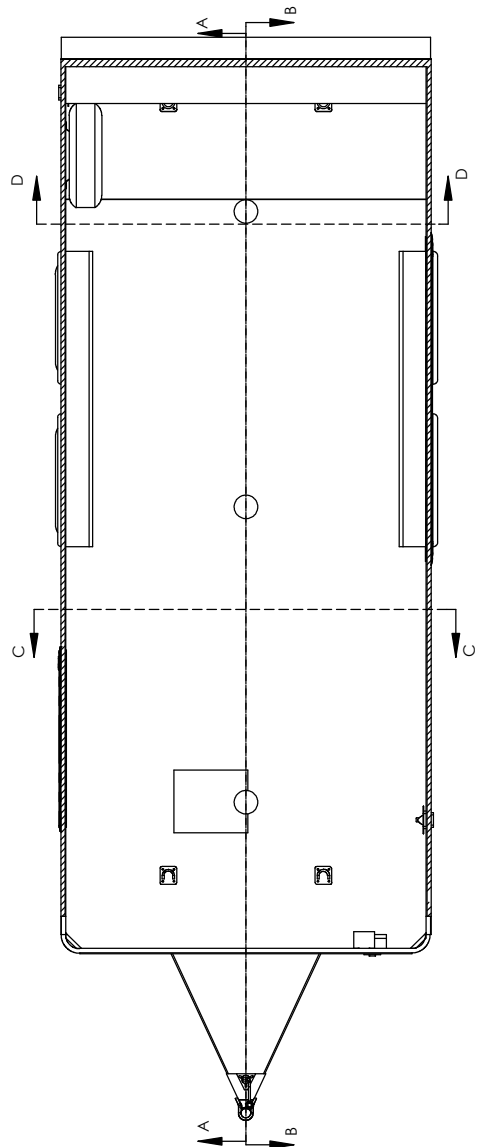
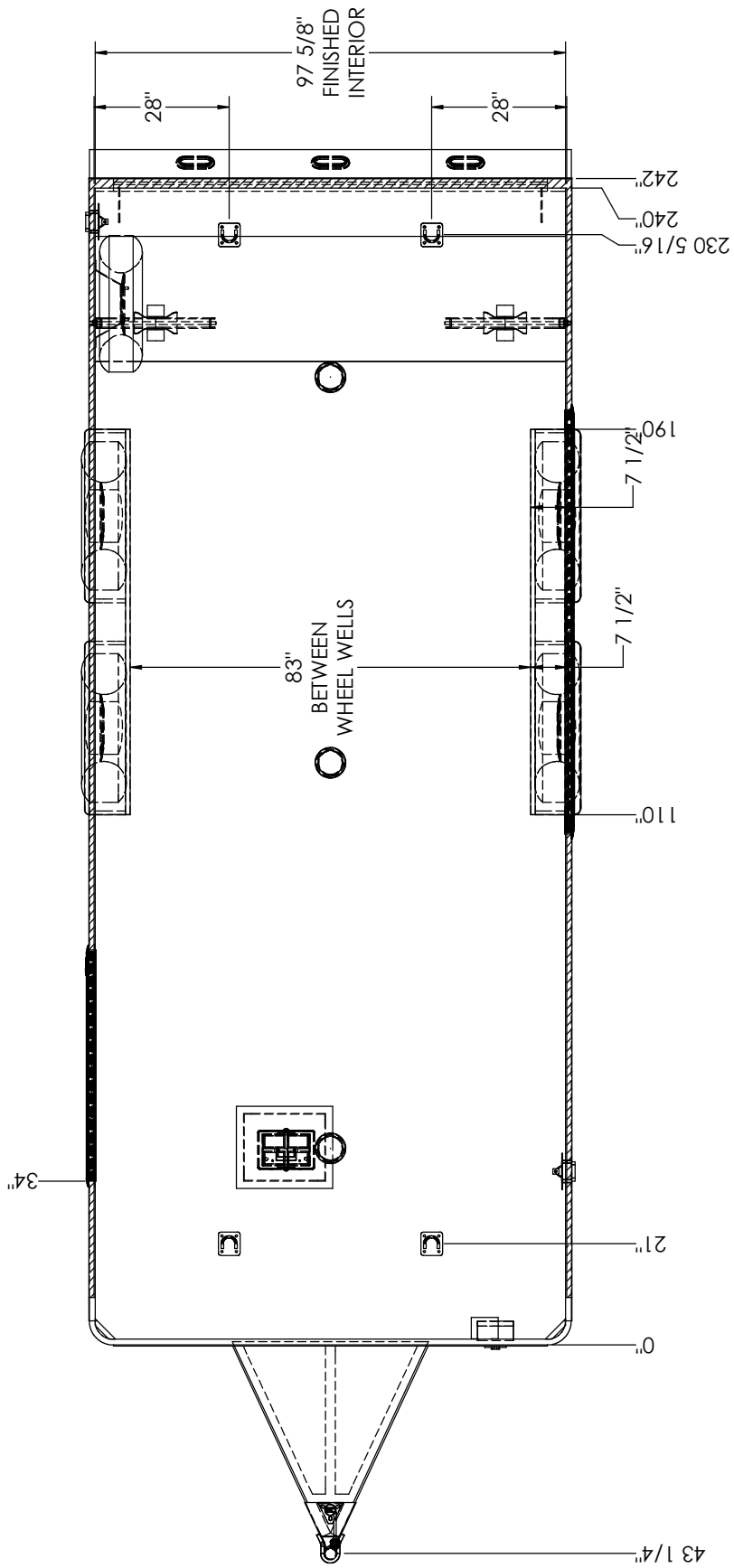

TITLE: 8520+0-2T ALUMINUM		REV.:
DRAWN BY: GOM	DATE: 03/03/16	VIN/PART # 203970 F
FILE NAME: DW-BP 8524-Becker-Schacht-203970		SCALE: 1:15
DATE PRINTED: 3/24/2016		SHEET 2 OF 6

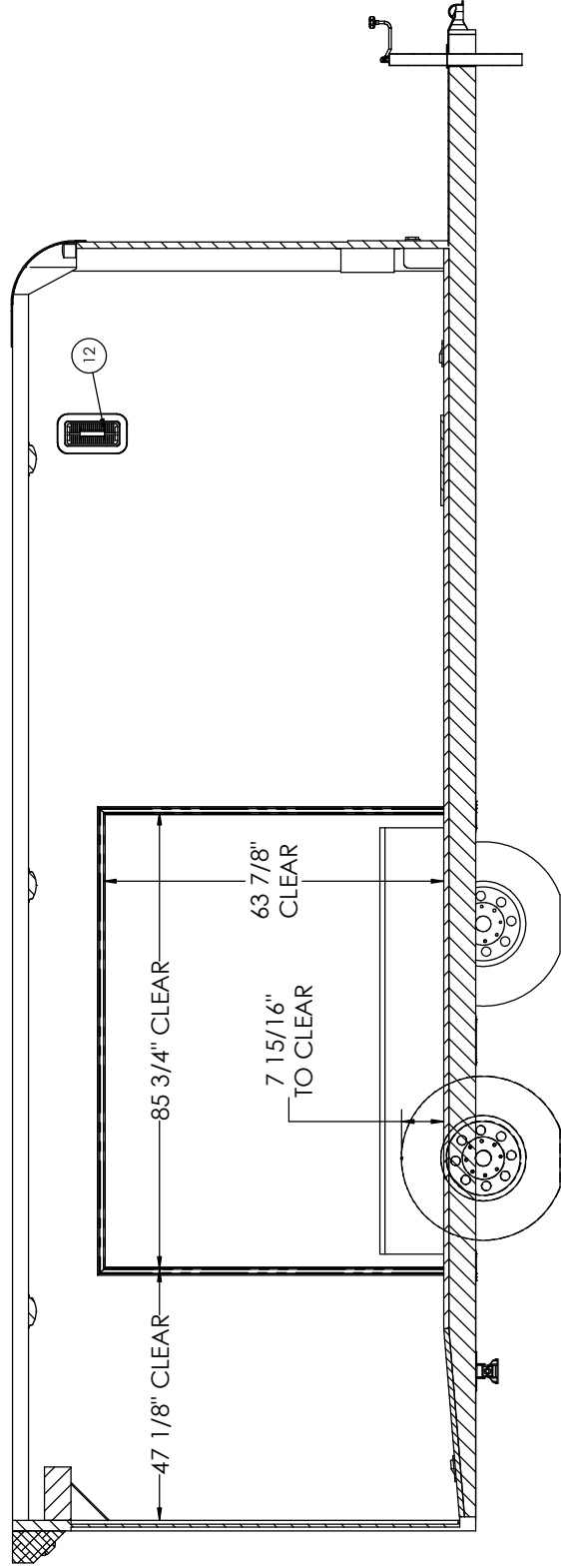
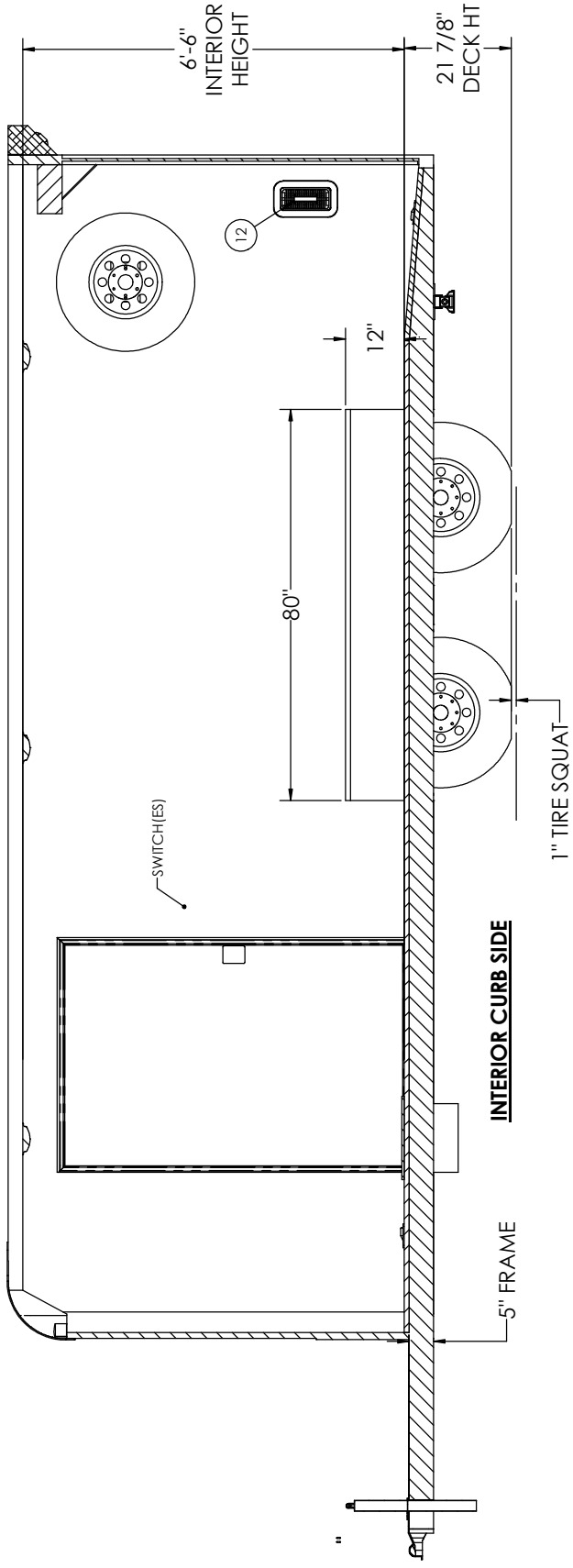

INTERIOR ROAD SIDE



TITLE:	8520+0-2T ALUMINUM		
DRAWN BY:	DATE:	VIN/PART #	REV.
GOM	03/03/16	203970	F
FILE NAME:	DW-8P-8524-Becker-Schacht-203970		
SCALE:	1:18	DATE PRINTED:	3/24/2016
			SHEET 3 OF 6

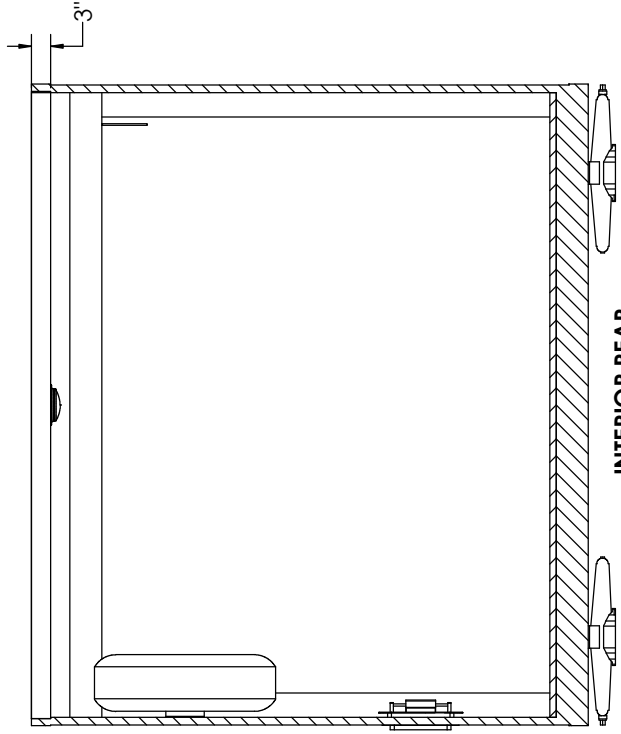
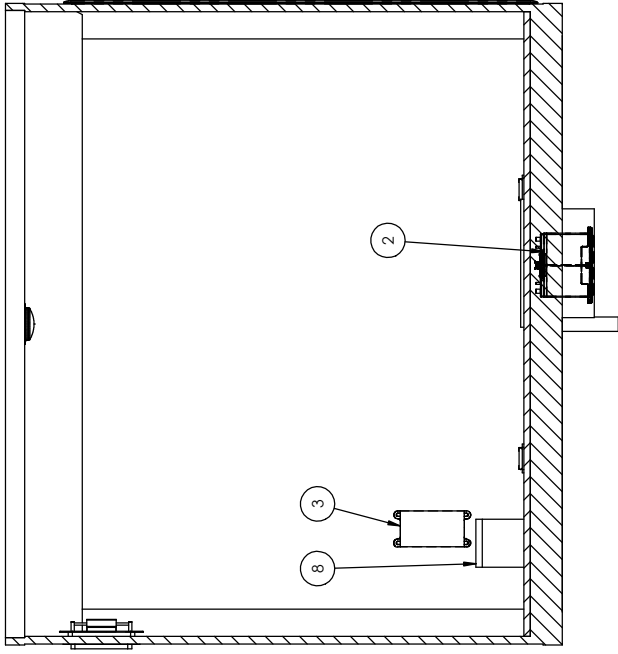
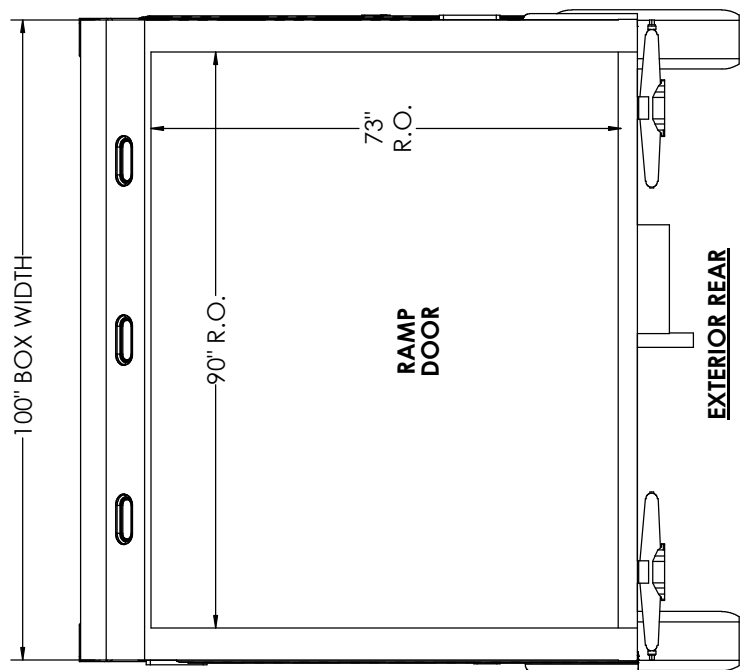
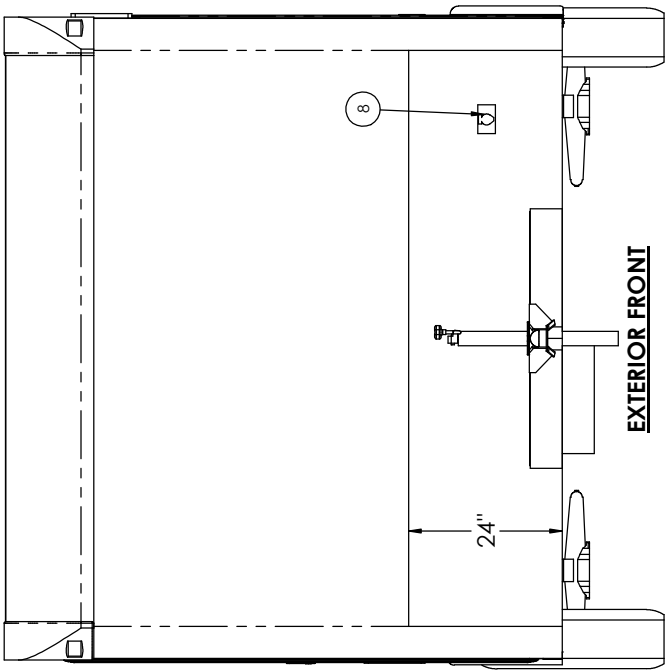

TITLE:	8520+0-2T ALUMINUM	REV.:	F
DRAWN BY:	GOM	DATE:	03/03/16
FILE NAME:	DW-BP 8524-Becker-Schacht-203970	VIN/PART #:	203970
SCALE:	1:15	DATE PRINTED:	3/24/2016
			SHEET 4 OF 6

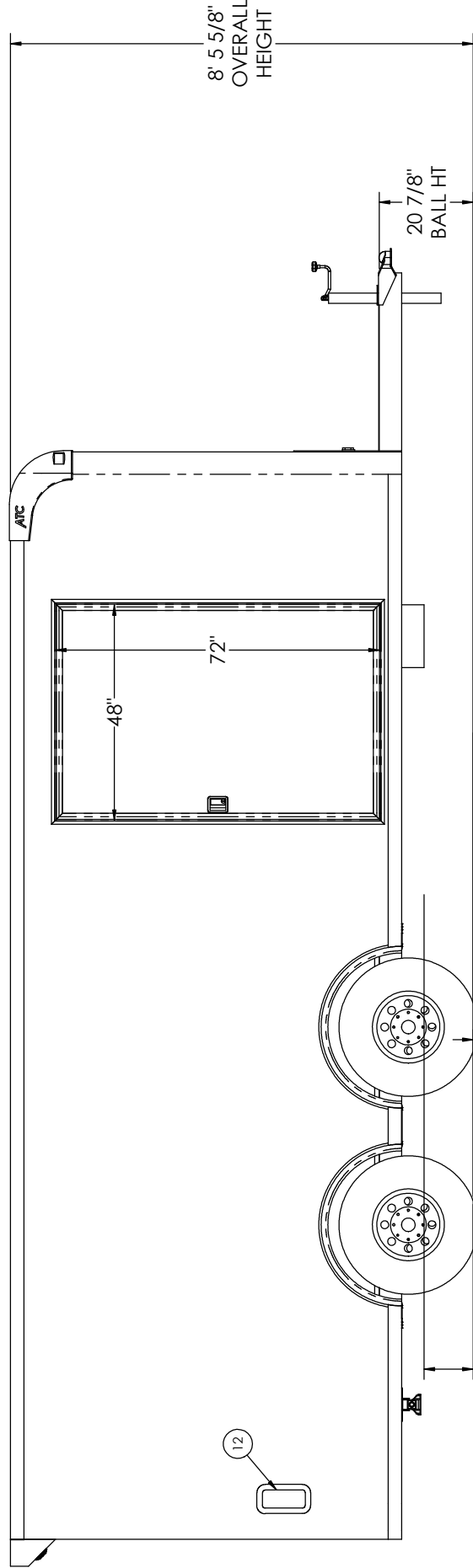
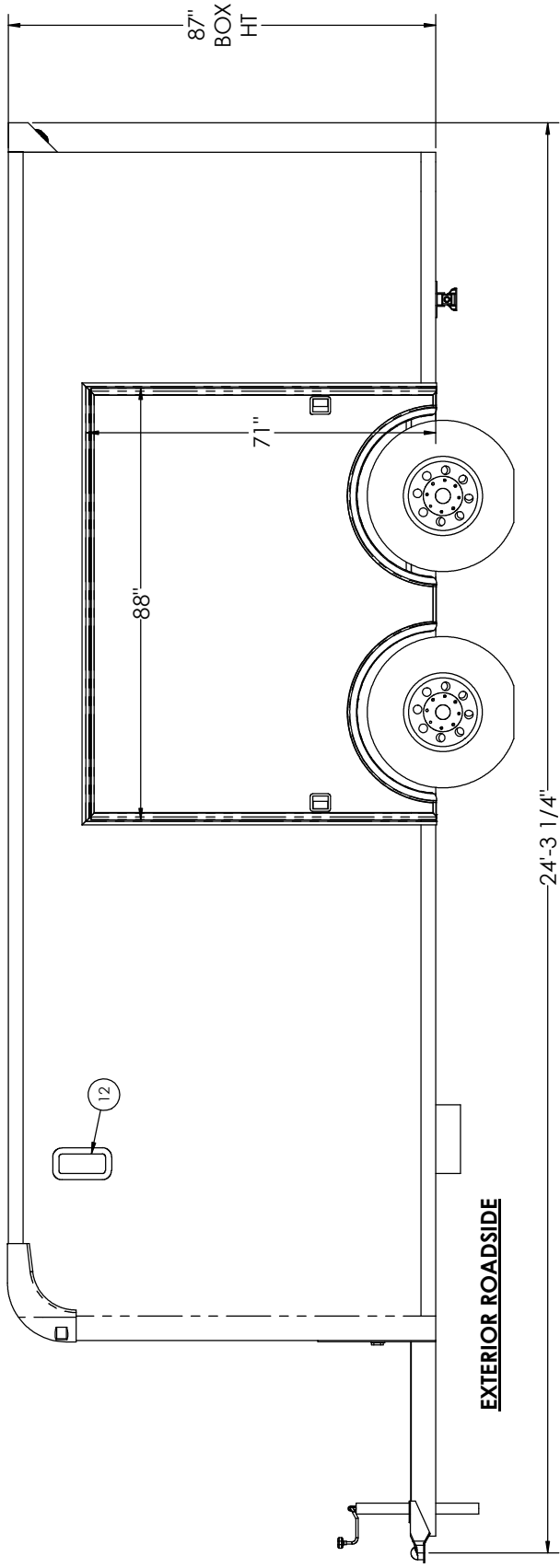

TITLE:	8520+0-2T ALUMINUM		
DRAWN BY:	DATE:	VIN/PART #	REV.
GOM	03/03/16	203970	F
FILE NAME: DW-BP-8524-Becker-Schacht-203970			
SCALE: 1:18			
DATE PRINTED: 3/24/2016			
SHEET 5 OF 6			

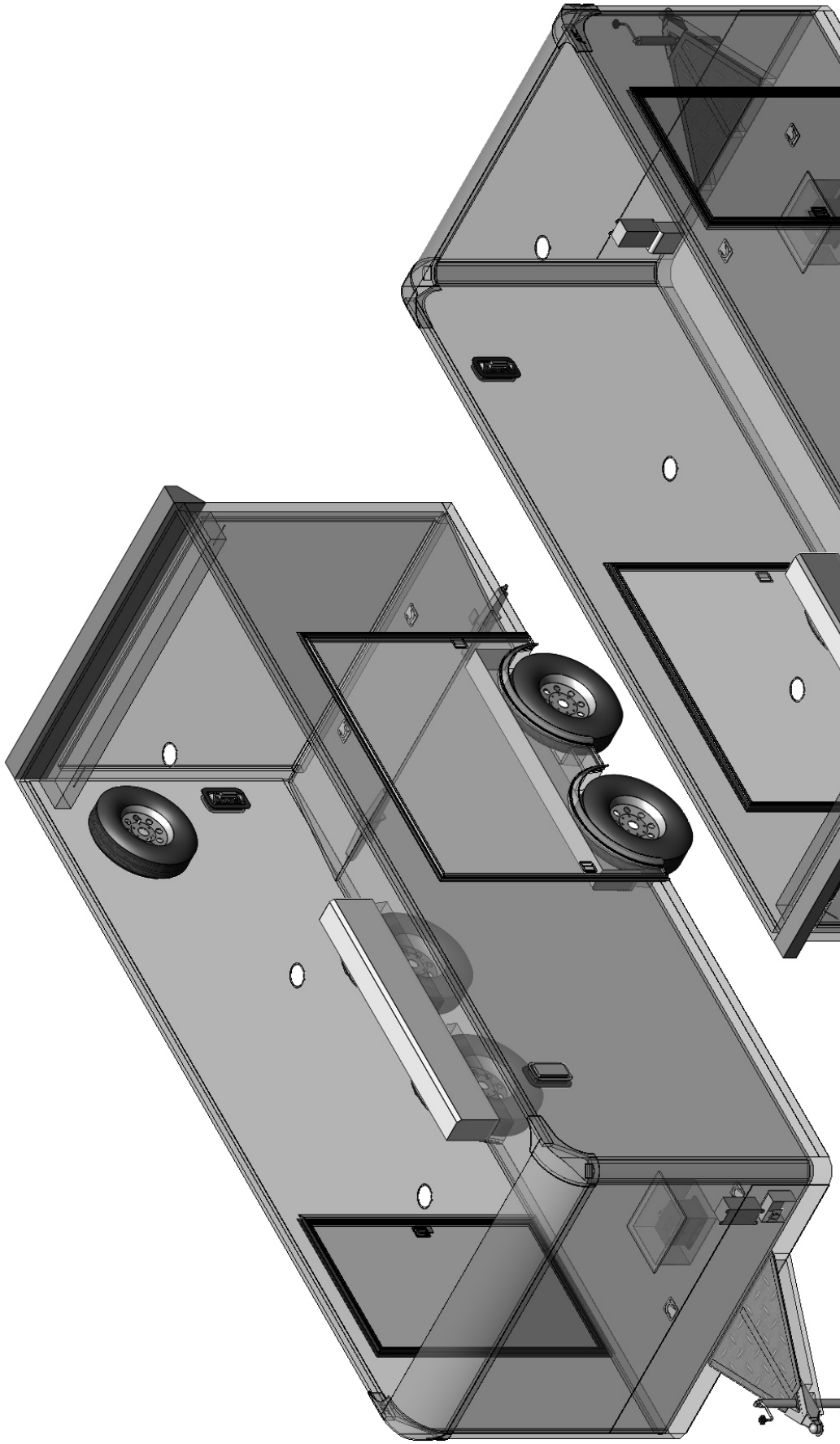

ROAD SIDE VIEW

CURB SIDE VIEW



TITLE:	8520+0-2T ALUMINUM			REV.:	
DRAWN BY:	GOM	DATE:	03/03/16	VIN/PART #	203970 F
FILE NAME:	DW-BP-8524-Becker-Schacht-203970				
SCALE:	1:20	DATE PRINTED:	3/24/2016	SHEET 6 OF 6	

ORDER CONFIRMATION:

By signing this order, the buyer acknowledges that the order and final prints have been reviewed and are correct in the regards to the buyer's specifications. It is the buyer's responsibility to review the final prints and order sheet in full extent as this document will serve exactly how the trailer will be manufactured. Any further changes required after sign off will impose a change order fee which will be determined by the complexity of the requested changes.

Once this agreement is signed, the buyer is fully responsible for costs incurred for any changes once the trailer is manufactured. By signing this agreement this will release Becker Custom from further responsibility or costs for these changes. Final payment is due 10 days before completion of the trailer. If a custom order is cancelled the deposit is non-refundable and a restocking fee will apply to total unit price.

By signing the buyer agrees to the terms of this agreement and acknowledges receipt of a copy. Buyer has read and understands this agreement in its entirety.

Signature: *Martin F. Schacht*
Martin F. Schacht (Mar 24, 2016)

Email: mfschacht@gmail.com