

“GT1” Engine Coolant Lines

The importance of water retention

BY TONY CALLAS AND TOM PRINE

You are driving your 996 Turbo on the open road. It's a cool autumn morning, and you've been enjoying the opportunity to open it up a little as traffic is light. Your exit is coming up, so you accelerate to get around some cars. The two-lane exit is long and has great forward visibility of the upcoming right, then left turns.

With no one ahead of or behind you, you decide to maximize the fun factor of the off-ramp and head into the first curve a bit faster than you might when your significant other is sitting in the passenger seat. Of course, it's nothing you haven't done many times before.

As you turn in, focusing on the first apex, you hear a muffled pop and then a faint squeal behind you — if you're lucky, because they're masked by the sound of the engine. Even if you start to think, *What was that?*, you'll only get to “what” before you begin to sense in the seat of your pants that the rear tires are no longer following the fronts. To your total disbelief, you realize the rear end is coming around.

You apply full opposite steering lock to no avail. It's like you're on ice, and the car proceeds to swap ends. You depress the clutch fully and get on the brakes, now going backwards. You get an awful feeling and brace yourself as you see the guardrail coming closer. But, just then, the car's tires regain traction and you come to a stop a little short of impacting the barrier.

What just happened? you think. *Was I hit from behind?* As your mind plays back the event, you glance in the rearview mirror and see what appears as smoke billowing from the back of the car. *What now? Fire?* Your adrenal glands go ballistic. You shut the engine off, unlatch the hood and the engine lid as you exit the car. You grab your fire extinguisher from the trunk and, as you reach the engine, realize what you thought was smoke is steam. There's coolant everywhere, including all over the rear tires. A coolant line let go, causing your spin.



A failed 996 GT3 cast-aluminum coolant manifold, 996 106 039 73.

Substitute this scenario for any driving situation — from freeway driving to canyon runs, from track days to heavy traffic, or simply sitting at a stop light. As you can imagine, there's dangerous potential if a failure occurs at the wrong time. Unfortunately, its timing cannot be controlled. If your Porsche has been tracked on a semi-regular basis, there may be a higher likelihood that this failure will take place. However, cars driven only on the street have experienced this problem, as well.

As in all water-cooled engines, coolant leaks can and do happen in water-cooled Porsche engines. Over time, you expect rubber coolant hoses to get hard and brittle after repeated heat and pressure cycles. Eventually, they crack and leak. You expect water-pump seals to start leaking as they age, causing their axial bearings to fail. What you may be surprised to learn is that the potential exists for a catastrophic failure of the cooling system in 996 and 997 Turbo, GT2, and GT3 models.

This *Tech Forum*, then, will examine an

unusual issue affecting cooling systems in some of Porsche's highest performing cars.

All in the Family

Porsche ended its production of the air-cooled flat sixes in 1998. At that time, the 911 (993) Turbo, with its M64.60 engine, was recognized as one of the world's premier high-performance sports cars. A replacement was a foregone conclusion. The powerplant for the next-generation 911 Turbo would have to be powerful, reliable, and meet ever-increasing emissions mandates worldwide. Porsche looked to its motorsports division at Weissach.

Porsche Motorsport had a lot of experience with water cooling the flat six boxer engine. The 935/78, 956, 961, and 962 race cars all utilized differing configurations of engine water cooling, as did Porsche's first road-going supercar, the 1988 959. For the 1996 racing season, Porsche Motorsport had designed and produced the twin-turbocharged 911 GT1 sports racer. It was based on the 993, but you had to look long

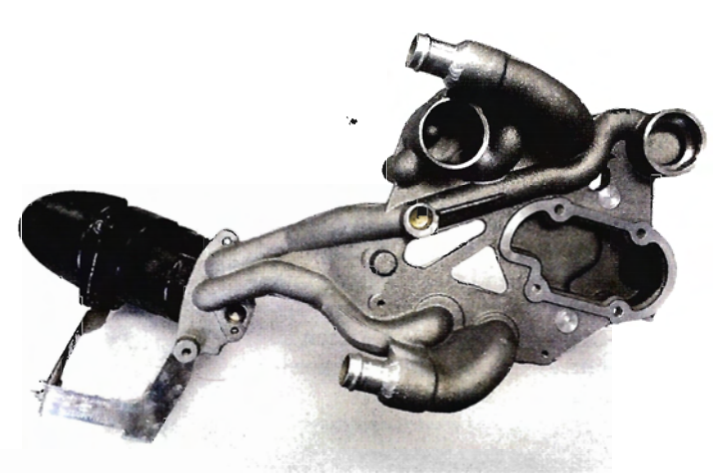
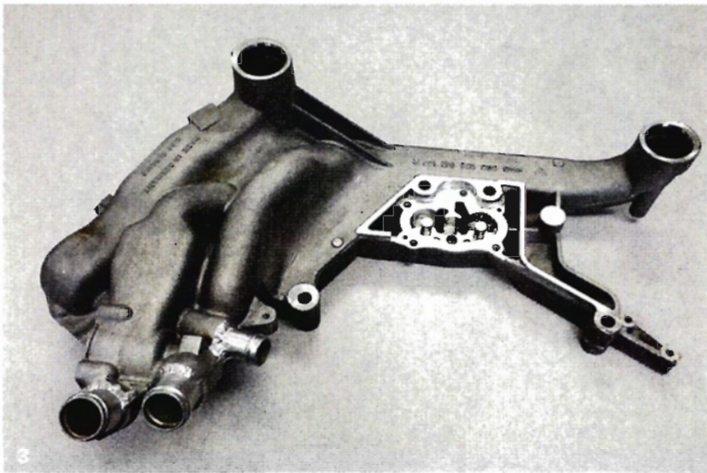
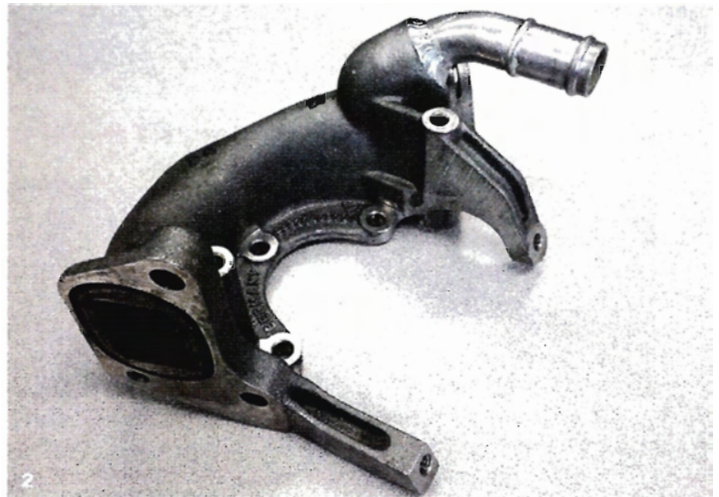

and hard to find the similarities. Porsche actively campaigned the GT1 through the 1996, 1997, and 1998 seasons. It sold GT1 race cars to privateer teams, and built 25 detuned “street versions,” as well.

The GT1’s six-cylinder boxer utilized a split-crankcase, eight-main-bearing design — a near duplicate of the air-cooled 964/993 engine. Unlike air-cooled 911 engines, however, which use six individual cylinder heads and six individual cylinders, the GT1 engine uses two water-cooled cylinder heads and two “cylinder blocks.”

The cylinder blocks, which consist of water-housing assemblies that mount to the crankcase, each contain three cylinder sleeves. The water-cooled cylinder heads, one per cylinder bank, feature two intake and two exhaust valves for each cylinder. Coolant is distributed to the heads and cylinders through a network of ancillary external coolant manifolds and hoses.

The GT1 engine performed fantastically; Porsche Motorsport had again produced a great racing engine. It then took the basic GT1 engine and developed new, normally-aspirated racing engines. The water-cooled GT3 Cup engine for 1998 and the GT3R engine for 1999 were both

996 106 039 73 after TIG-welding both extruded aluminum pipes (1). 996 GT3 coolant manifold following TIG welding, which mounts below the power-steering pump (2); 997 part is very similar. 996 GT3 water-pump housing after TIG welding (3). GT3 oil filter/heat exchanger manifold (4); both pipes have been TIG-welded into cast manifold, allowing the coolant to circulate through the heat exchanger.

descendants of the GT1. It should therefore be no surprise that Porsche chose to use the basic design of the GT1 engine for its line of high-performance road 996s.

The M96.70 and M96.70S engines were introduced to the U.S. market in the 2001–2005 996 Turbo and 2002–2005 996 GT2. The 2004–2005 996 GT3 was powered by the high-revving, normally-aspirated M96.79 — an engine that was only slightly detuned from the GT3 Cup unit, with many of its parts being the same or interchangeable. The 2007–2009 997 Turbo with the M97.70 engine came next. The 2007–2008 997 GT3 and GT3 RS used the M97.76 engine, while the 2008–2009 997 GT2 used the M97.70S engine.

While these flat sixes are commonly referred to as “GT1” engines, we refer to them as the M96.70 and M97.70 engine

family. While there are differences between them, the parts and issues relating to the cooling system are fundamentally the same.

The Problem

The M96.70 and M97.70 engine family are of a hybrid design, meaning they combine components from the older, air-cooled 911 engine with new, liquid-cooled cylinders and heads. As such, there are no provisions within the crankcase that allow coolant to circulate between both sides of the engine. Circulation of the coolant is achieved through an externally mounted water pump, coolant manifolds, and hoses. By comparison, M96.01 Boxster and M96.20 Carrera engines were designed to use a water pump that is mounted in the crankcase as well as coolant passages throughout the engine.

The external plumbing of the M96.70 and M97.70 engines in and of itself is not the issue; the construction of the coolant manifolds is the problem. All versions of the M96.70 and M97.70 family have multiple cast-aluminum coolant manifolds attached to the engine. Extruded aluminum piping extends out from the cast manifolds and serves as attachment points

for all rubber hoses. The extruded aluminum pipe fits into the manifold and is held in place by glue or a bonding agent. The failure point is between the cast manifold and the extruded aluminum pipe, and is caused when the glue or bonding agent fails and allows the extruded aluminum pipe to separate from the cast manifold while the engine is running.

As mentioned in the December 2010 *Tech Forum*, 2008–2009 Cayenne V8s are known to have a similar problem. An extruded aluminum pipe pops out of the cylinder-head crossover manifold that connects the right and left cylinder heads at the rear of the engine. When this separation occurs, hot and pressurized coolant will explode out of the manifold at high velocity and in significant volume.

The effect will be immediate, with no warning and likely no sign of a problem prior to the failure. Depending on which connection fails, it may have an effect on the direction of escaping coolant. But within the tight quarters of an engine compartment, coolant may go in all directions. If coolant gets onto the tires in sufficient quantity, a sudden loss of traction could occur.

Why

We cannot say why the bonding agent fails at this time, but a few thoughts come to mind. It seems possible that inconsis-

Preparing to reinstall heat exchanger manifold (5) with new O-rings and seals. Moving manifold into position (6) with top of engine apart for better access. Checking O-ring seal (7). Four O-rings (999 707 411 40) on top of engine are held in place by right and left cylinder head coolant manifolds (8). Parts breakdown for M96.70 driver's side coolant manifold (9) and 997 GT3 driver's side coolant manifold (10). 996 driver's side coolant manifold following TIG welding (11). View from back of 997 GT3 driver's side manifold (12); note addition of curved hose 997 106 233 72 and coolant pipe 997 106 252 90.

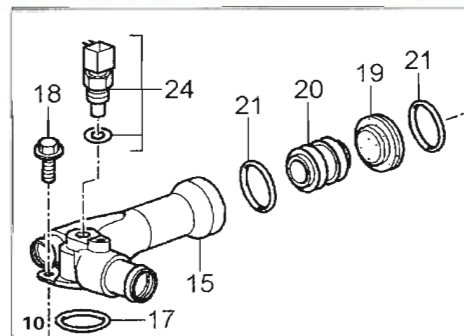
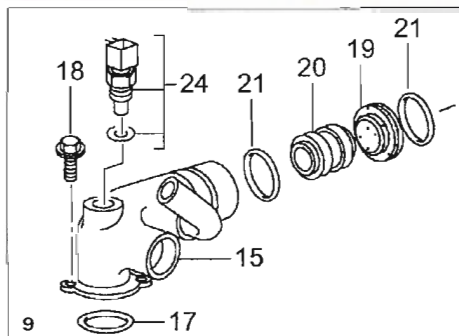
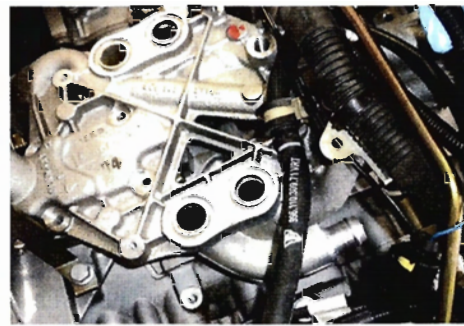

tencies in the quantity and/or quality of the bonding agent applied during the manufacturing process could be a suspect. A poorly bonded connection of newly manufactured parts may pass all quality control inspections but fail in time. Years of high heat and pressure cycles may cause the part to fail prematurely.

Cars with cooling-system issues that go unresolved for periods of time could potentially cause or contribute to this problem. Coolant leaks are problematic not just because of the liquid volume loss, but also because of air intrusion into the cooling system. This can cause the engine to run warmer than its normal operating temperature range, which

in turn also increases the pressure within the system.

The coolant reservoir is a common failure point in modern Porsches. As the reservoir ages, its material becomes brittle and cracks, causing leaks. The front radiators are another place to watch for leaks; they should be kept clean, as collected dirt and road debris will cause cooling efficiency to drop. Also, a radiator fan that is not operating properly will cause higher operating temperatures and pressures. (Remember: The GT3 only has one fan.)

Renewing the coolant is an important part of servicing your car. The coolant has a PH factor that will turn acidic over time when exposed to aluminum. It should also

be mentioned that it is critically important to bleed as much air out of the system as possible when flushing the cooling system. Coolant flushes should be done every two to three years. Additionally, when filling or topping off your cooling system, only use the factory brand coolant and/or distilled water; this is best done when the system is cold, such as first thing in the morning.

The point here is to keep the cooling system operating at maximum efficiency. Over time, higher-than-normal operating temperatures and pressures can take a toll on your engine and cooling system. With respect to bonding agents for the coolant manifolds, this may accelerate failure regardless of the root cause.

A Common Failure Point

We want to stress that a failure point can potentially be at any location where the extruded aluminum pipes are bonded. That said, there seems to be one point that has been more likely to fail than others. Sitting on top of cylinder bank #1 — driver's side in left-hand-drive cars — is a cast-aluminum manifold (part number 996 106 039 73). This manifold is shaped like an "L" and has a long, curved extruded aluminum pipe extending out from the rear-facing (of car) side of the manifold. This pipe seems to fail more often than the others.

Interestingly, Porsche changed this part on M97.76 (GT3) engines to part number 997 106 039 90, which is of a different configuration and does away with the curved pipe altogether. The updated part is from the 997 GT3 and will fit all versions of the M96.70 engines in the 996 Turbo, GT2, and GT3. The same part on a 997 Turbo or 997 GT2 is different. The 997 GT3 part is a tight fit in the older cars and will also require the addition of part numbers 997 106 233 72 (hose) and 997 106 252 90 (coolant pipe). All other flanges, O-rings, and components are the same.

Misconceptions

We have heard suggestions that failures

have occurred due to problems with one or more of the four manifold O-rings on top of engine part number 999 707 411 40. These O-rings could be the source of a leak if damaged during installation — or if they become brittle and crack over time. However, this would be an unlikely cause of the catastrophic coolant loss as experienced when a coolant pipe separates from the coolant manifold.

Options

The repair of a specific, single-point failure can most likely be accomplished with the engine in the car — but this is dependant on the location and access to the parts. If you opt to modify all potential failure points of the system as a preventative repair, removing the engine and transmission as a unit will provide much better access. It will also simplify the task of dismantling and reinstalling all of the components involved.

With the engine in place, you'll need to disassemble and remove the induction system to gain access to the coolant manifolds and oil cooler. Due to the cramped quarters in a 996/997 engine compartment, we feel engine removal is a wiser choice in the long run. While the engine is out, consider replacing all hoses, O-rings, etc. on the

engine as part of the job. The cost is relatively low and little additional labor is required, as everything is apart anyway.

Option 1: TIG-weld the original extruded aluminum pipes into the cast aluminum manifolds. This may be your best option, as it provides a permanent repair. Prior to the TIG-welding process, the bonding agent should be removed from the parts. If this is a preventive repair, all extruded aluminum pipes must be removed from the manifolds. This involves using a MAP gas torch to heat the cast-aluminum manifold near — but not on — the connection point with the aluminum pipe until the bonding agent starts to ooze out of the connection. It is important that the heat being applied to the aluminum pipe is not excessive, as that could distort the pipe, rendering it useless.

With the bonding agent softened, the extruded aluminum pipe can be removed. Be careful not to damage it. Both the pipe and manifold must be cleaned with a wire brush to remove any residual bonding agent. A high-quality aluminum hose fitting with the correct outside and inside dimensions can be used or substituted for a damaged extruded aluminum pipe. The parts are reassembled and TIG-welded at



Licensed Porsche® Mats Available For Your Porsche®



Features:
Highest quality Licensed Porsche® Mats available.
60 Porsche® emblems to choose from.
Custom embroidery & options available.
18 mat colors offered & additional colors available.
Rubber & vinyl mats available.
(not a Porsche® licensed product)
Order up to 6pc set.
Order Licensed Porsche® Mats in many combinations.
18 embroidery colors offered.
Cheaper pricing than dealerships.
(Offset alignment for Cayenne mats only.)

Order your Licensed Porsche® Mats in any color with any Porsche® emblem(s). You can order single or double embroidery with one or two colors. A 5yr. ltd. mfg. warranty comes with Licensed Porsche® Mats.

Ordering/Questions/Info
1-800-816-0929
www.hwaccessories.com



Licensed Porsche® Mats are manufactured by Lloyd Design Corp. under license from Porsche® AG. All emblems shown on mats for Porsche® vehicles are trademarks of Dr. Ing h.c.f. Porsche® AG.





Better Technology
Better Performance
Better Quality

**Wavetrac is DIFFERENT:
It's the ONLY gear diff
that keeps driving when
others can't.**



See how at: www.wavetrac.net/different

Designed & Manufactured in the USA
by AUTOTECH Driveline

Now available for these Porsche models:
901: 911, 914 1969-74
915-18: 911, 930 1974-77
915-43: 911 1978-86, 930 1978-88
G50: 911 '87-88, 930 5spd '89>, 964, 993, 968
996 6MT, 986 BOXSTER S 6MT
944 1986>
987 CAYMAN S / BOXSTER S (3.4L 6MT)
997 6MT

Contact us to locate an authorized dealer:
www.wavetrac.net 949.362.8700

the joint between the pipe and manifold.

If you elect to go this way, be sure to work with a professional welder who is experienced at TIG welding light-gauge aluminum piping to thick cast aluminum.

Option 2: Re-glue the extruded pipe back into the cast manifold without removing the manifold while the engine remains in the car. This can be a good choice to repair a single-point failure when a quick fix is needed and/or a longer-term preventative repair is not in your interest. Use only a high-quality, epoxy-type bonding agent that is corrosion-resistant and designed for high temperatures and high pressures.

Option 3: Tap threads into the cast manifolds and install screw-in hose connection fittings. *Note: These must seal very well.* Basically, there are two different types of threads used for fittings — tapered (pipe) and straight. In this case, it is not recommended to utilize tapered threads because of the load placed on the brittle cast-aluminum manifold by an installed fitting. It is possible to tap straight threads into the cast-aluminum manifolds, but there is no sufficient means to seal the threaded insert without significant machining. Because of these reasons, we feel that this is not a practical option.

Option 4: Pin the extruded aluminum pipes into the cast manifolds. After a hole is drilled through the manifold and the extruded aluminum pipe, the hole is tapped with threads and a screw is installed with a thread sealer. This will only prevent the extruded pipe from coming out. However, we are concerned about any coolant leakage from the additional hole.

Option 5: Replace the old, faulty manifold with a new factory piece. This will keep the vehicle “factory,” but we suspect it is somewhat likely that the new manifold will suffer the same failure in time.

Conclusion

Many of these Porsches with mileage over the 70,000 mark have never suffered the failure described in this *Tech Forum*. On the other hand, there are street-driven cars that have, some of them with less than 30,000 miles — *but* the number of these failures still appears to be quite low. In street-only cars, no clear trend in failures has been established, but this may change in time. For track-driven cars, the failure rate appears to be much higher.

To gain more perspective, we asked several well-known professional Porsche rac-

ing teams about their experiences with this cooling-system manifold failure. Almost all of them weren't even aware of the problem, or had never experienced a manifold failure even though the GT3 Cup race car uses the same coolant manifolds the street cars do. We did hear that some failures have occurred specifically in the 2007 997 GT3 Cup due to an inadequate quantity of bonding agent applied to the pipe and manifold connections.

If you track a water-cooled Turbo, GT2, or GT3 regularly or drive very aggressively, consider a preventative modification to eliminate the possibility of this failure. As these Porsches get older and reach higher mileage, this problem may become worse. But it's also possible that it won't.

At this time, modifying all bonded connections in the cooling system appears to be the only way to totally eliminate the possibility of future failures. If a failure does take place, you have some options to consider. Enjoy your Porsche. ■

Some technical information used in this article is copyrighted by and used with the permission of Porsche Cars North America. All photos by Tom Prine except where noted. Have a technical question? Email us at: techforum@excellence-mag.com



AWA
AutoWerks of America

OEM, Aftermarket & Performance Parts For Your Porsche

Replacement Parts by
Genuine Porsche
Bosch
Brembo
Continental
Denso
Goetze
Hella
Mann
Pagid
Textar
Sachs
Sebro
Victor Reinz
Zimmerman

Performance Parts by
Bilstein
Eibach
Fabspeed
Hawk Performance
Hotchkis
K&N
Koni
Mantis Sport
Momo
Pagid RS
PowerSlot
Remus Exhaust
Sparco
and many others

FREE SHIPPING
on orders over \$75
Lower 48 States Only

Great Accessories, Too!

- Park 'n Place Only \$12.99
- CG Lock Only \$44.99
- Altec License Plate Only \$144.99

(888) 4 A-Werks
www.AutoWerksOfAmerica.com
Celebrate Your Passion!



DELIVERING THE HIGHEST STANDARDS IN

**REBUILT
CAYENNE
DRIVE / CARDAN
SHAFTS**

ALSO AVAILABLE FOR
AUDI Q7 & VW TOUAREG

\$389 PLUS CORE CHARGE

FREE SHIPPING • 1 YEAR WARRANTY

866.668.0660
VERTEXAUTO.COM