

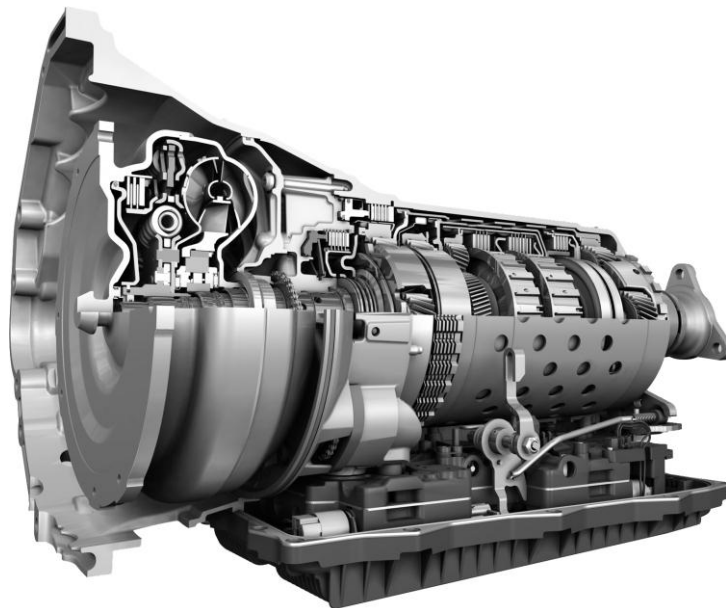

8HP45

8-Gang-Automatgetriebe für Pkw
8 speed automatic transmission for cars



Getriebetyp / Transmission type		8HP45	
Antriebsart Type of drive		Standard / Standard drive	
Eingangsdrehmoment Input torque		max. 450 Nm	max. 500 Nm
Drehmomentwandler Torque converter		NW 235 TTD/ZDW/DAT NW240 DAT	NW 240 DAT (Diesel / diesel)
Standard-Übersetzungen / Standard ratios Gang / Gear			
	1	4.714	
	2	3.143	
	3	2.106	
	4	1.667	
	5	1.285	
	6	1.000	
	7	0.839	
	8	0.667	
	R	-3.295	
Getriebespreizung Transmissions spreading		7.071	
Masse ohne Anbauteile (incl. Öl) Weight without ancillaries (incl. oil)		77 kg	79 kg
Ölmenge Oil capacity		≈ 9 dm ³	
Getriebeöl Transmission oil		Lebensdauerölfüllung Lifetime oil fill	

8HP45

Einbaumaße / Installation dimensions

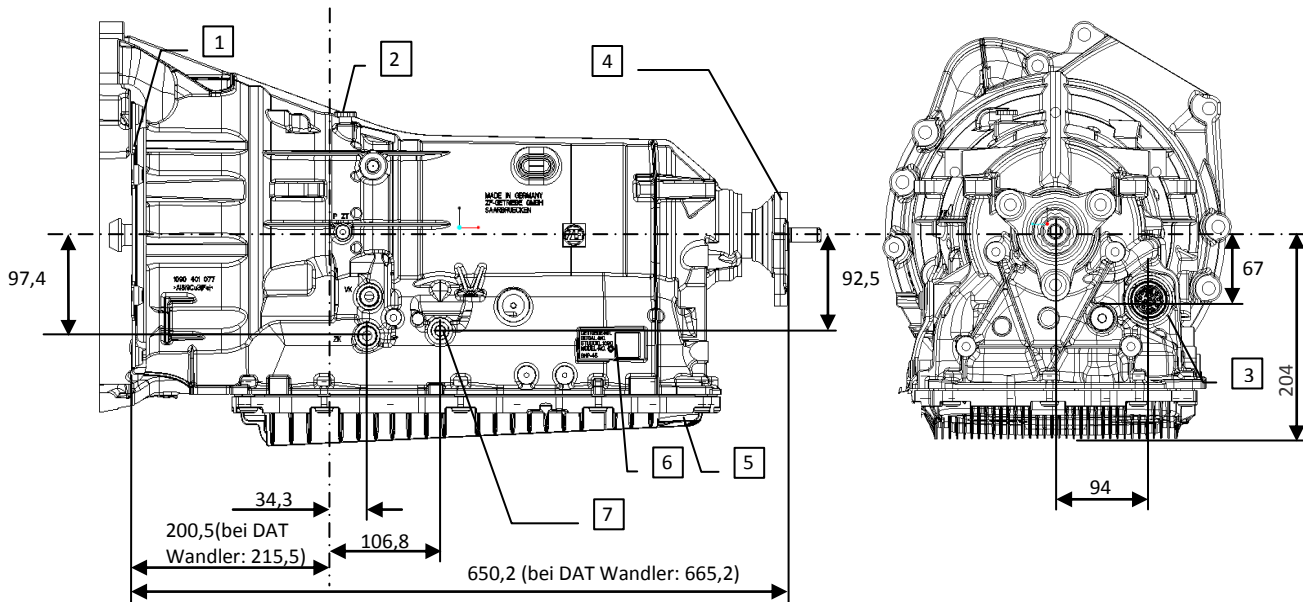

- | | | | |
|---|---|---|---|
| 1 | Wandler / Torque converter | 5 | Ölablass / Oil drain |
| 2 | Entlüfter / Breather | 6 | Öleinfüllung und Ölüberlaufmessung /
Oil fill and oil overflow |
| 3 | Steckeranschluss zum Fahrzeugsystem /
Plug connection to vehicle systems | 7 | Notentriegelung Parksperr (Shift-by-wire) oder
Wählhebel (manuell)
Emergency disengagement of parking brake
(Shift-by-wire) or selector lever (manually) |
| 4 | Abtrieb / Output | | |

Highlights

- Hohe Gesamtspreizung bei kleineren Gangsprüngen / High total spreading with small gear steps
- Niedere Schleppmomente / low drag torque
- Hochwirksame Torsionsschwingungsdämpfer / highly effective torsionsvibration absorber
- Standabkopplung / Neutral idle control
- Mechatronik / Mechatronic
- ASIS – adaptive Schaltstrategie / ASIS – adaptive shifting strategy
- Hohe Leistung bei geringem Gewicht, Innovatives Radsatzkonzept / High power-to-weight ratio, innovative gear set concept
- Allradfähig / AWD capable