

WM 508119 REMOVING AND INSTALLING CROSS PANEL > PRELIMINARY WORK

>

PRELIMINARY WORK FOR LEFT CROSS PANEL

1. Remove cowl panel cover. → REMOVING COWL PANEL COVER - section on "Removing"
Remove front trim panel (engine compartment) at the left. → REMOVING FRONT TRIM PANEL (ENGINE COMPARTMENT) - section on "Removing"

WM 508119 REMOVING AND INSTALLING CROSS PANEL > PRELIMINARY WORK

>

PRELIMINARY WORK FOR RIGHT CROSS PANEL

1. Remove wind deflector cover. → REMOVING COWL PANEL COVER - section on "Removing"
Remove front cover (engine compartment) at the right. → REMOVING FRONT TRIM PANEL (ENGINE COMPARTMENT) - section on "Removing"
- 2.
3. Remove DME control unit. → REMOVING DME CONTROL UNIT - section on "Removing"

WM 508119 REMOVING AND INSTALLING CROSS PANEL > REMOVING CROSS PANEL > REMOVING LEFT CROSS PANEL

1. Unclip plug connections -1- from the bracket.

Fig 1: Identifying Plug Connections From Bracket

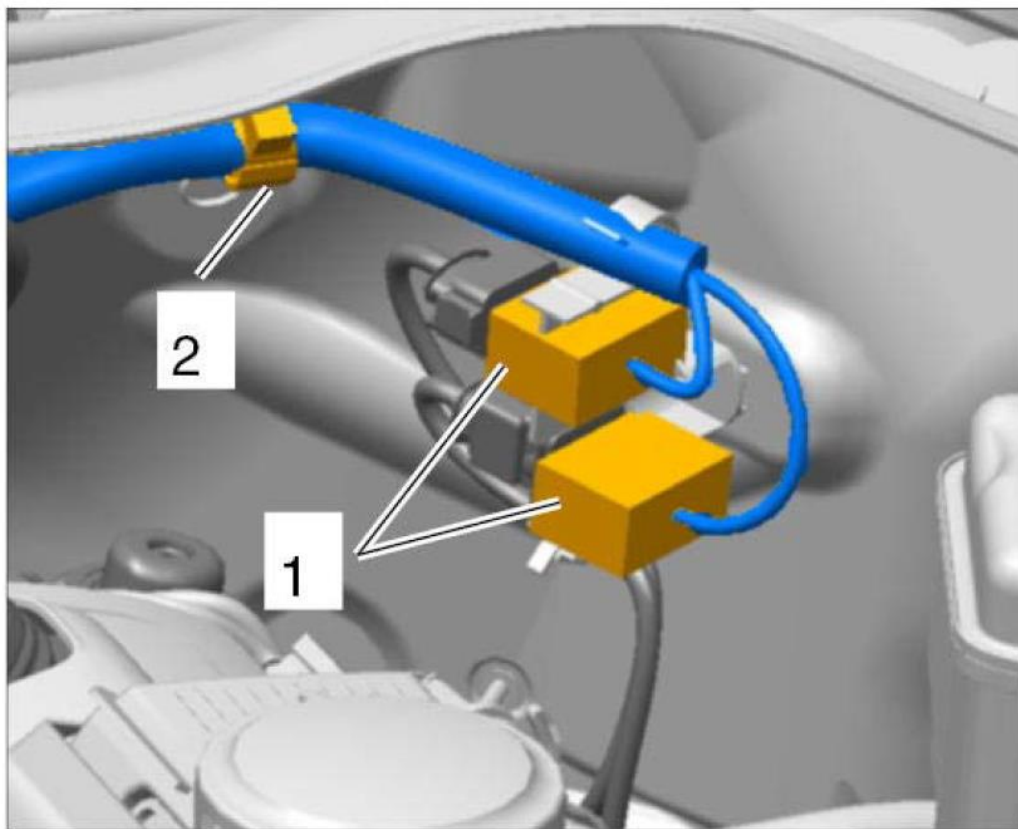

Courtesy of PORSCHE CARS NORTH AMERICA, INC.

2. Unclip wire harness -2- from the bracket.

3. Unscrew three fastening screws -3- .
- Fig 2: Removing Left Cross Panel

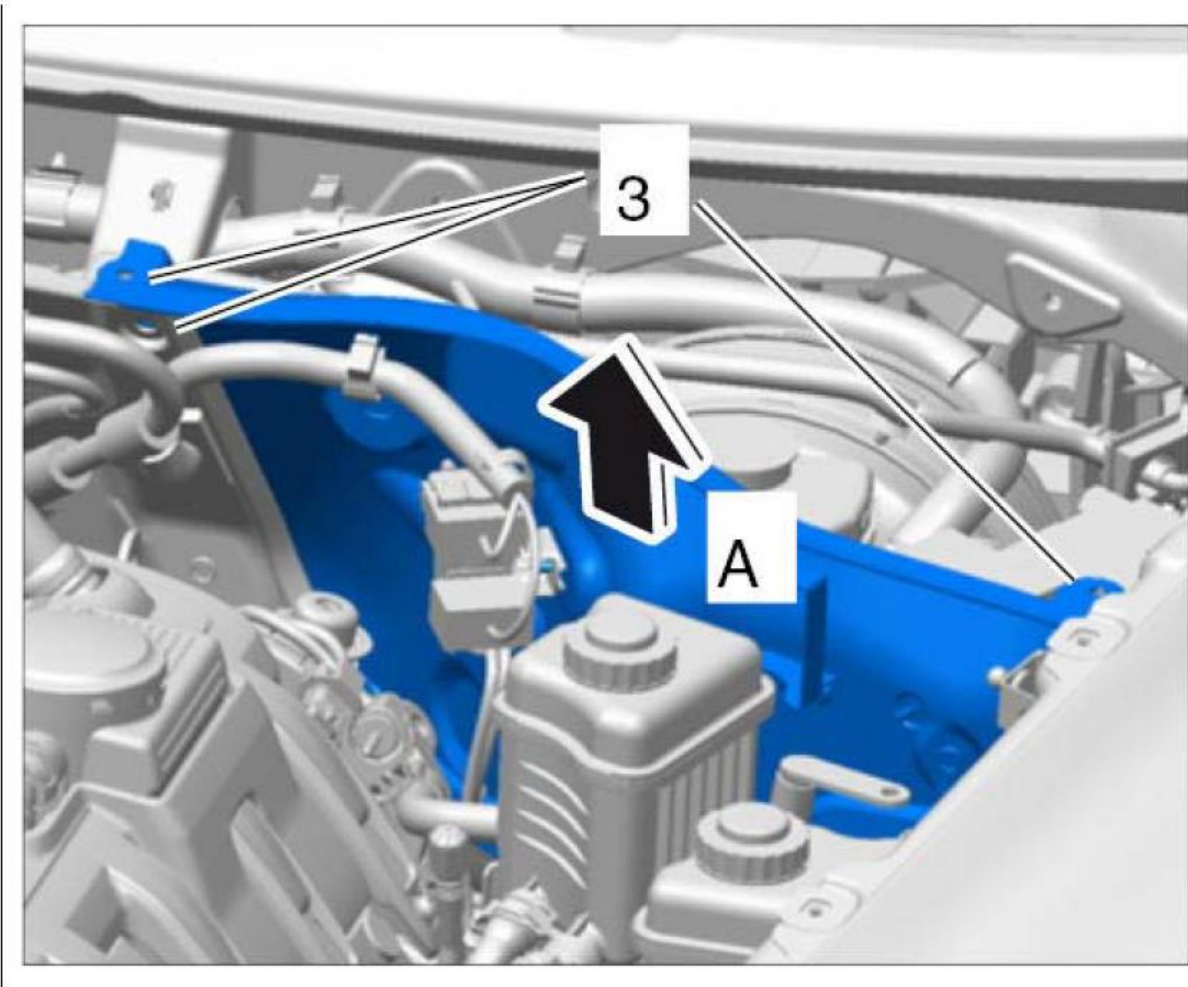

Courtesy of PORSCHE CARS NORTH AMERICA, INC.

4. Lift cross panel up and remove it -A- .
- WM 508119 REMOVING AND INSTALLING CROSS PANEL > REMOVING CROSS PANEL > REMOVING RIGHT CROSS PANEL**
1. Unclip plug connections -1- from the bracket.

Fig 1: Identifying Plug Connections From Bracket

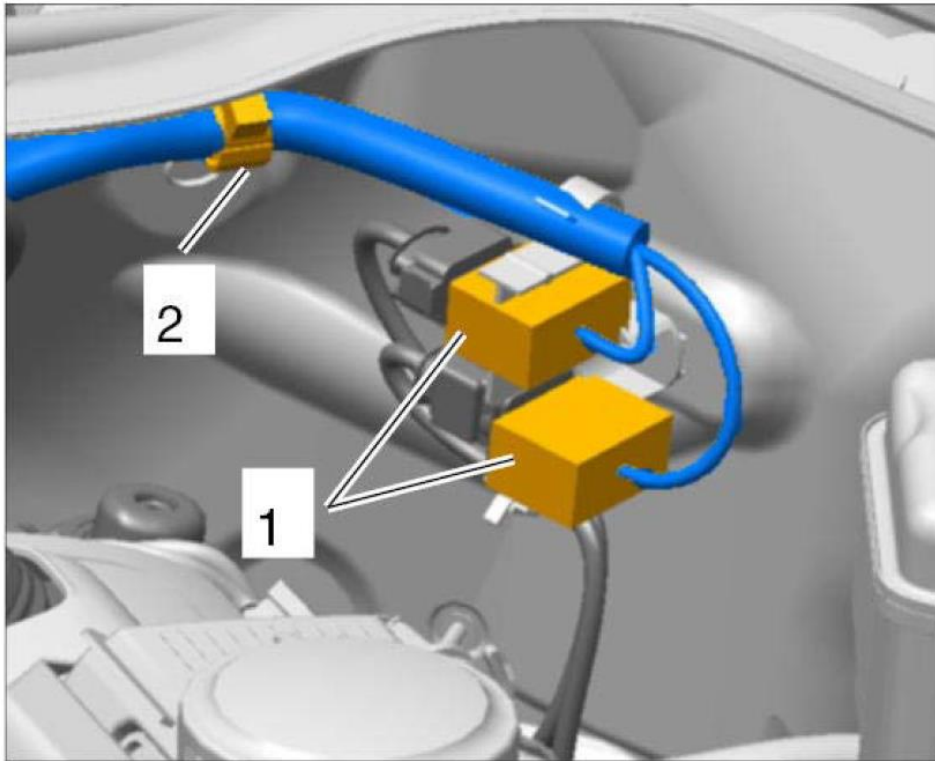

Courtesy of PORSCHE CARS NORTH AMERICA, INC.

2. Unclip wire harness -2- from the bracket.
3. Open two tie-wraps -1- .

Fig 2: Identifying Tie-Wraps Wire Harness

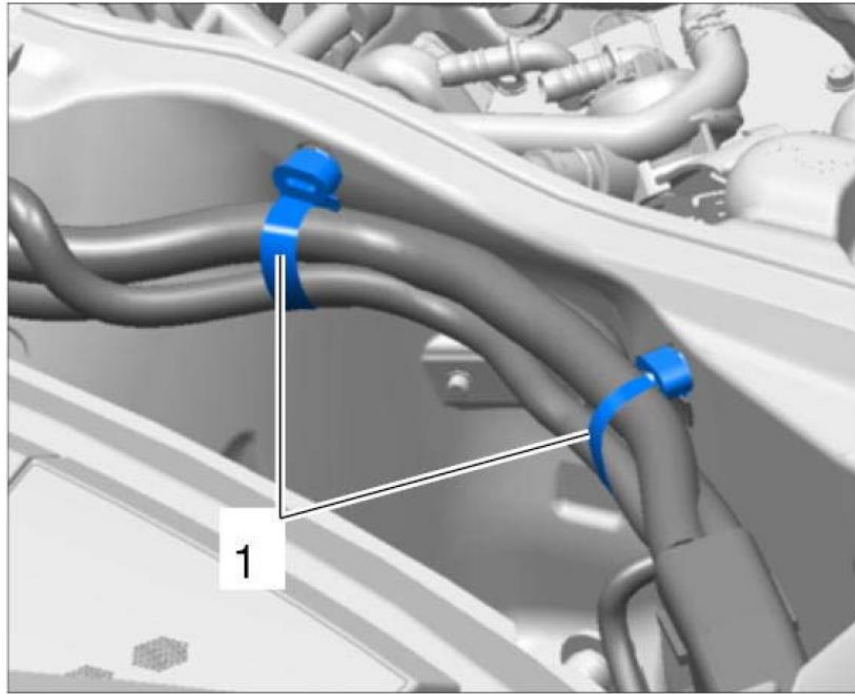

Courtesy of PORSCHE CARS NORTH AMERICA, INC.

Remove rubber sleeve on cable bushing -1- from the cross panel -A- .

Fig 3: Removing Rubber Sleeve On Cable Bushing From Cross Panel

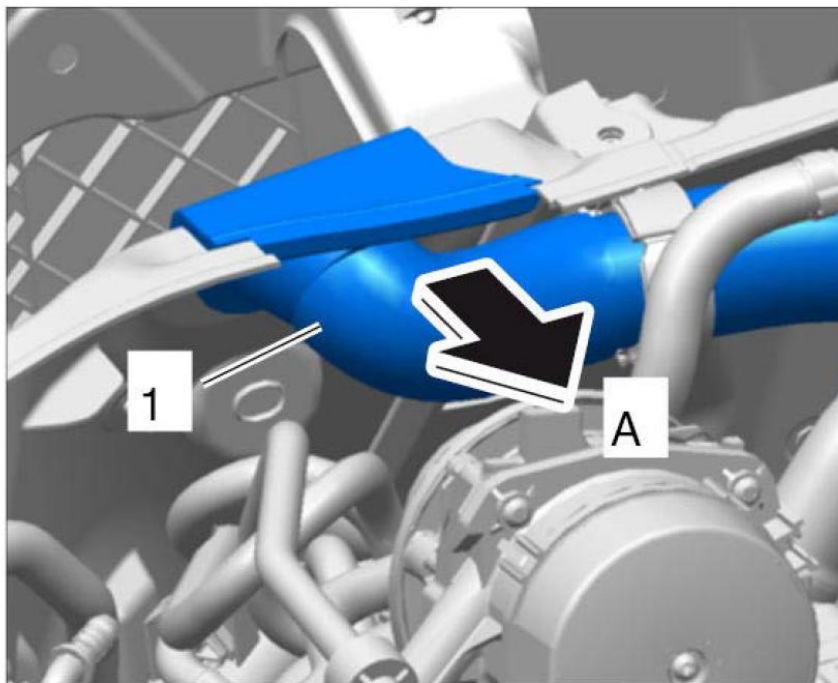

Courtesy of PORSCHE CARS NORTH AMERICA, INC.

5. Unscrew three fastening screws -3- .

Fig 4: Removing Right Cross Panel (Left)

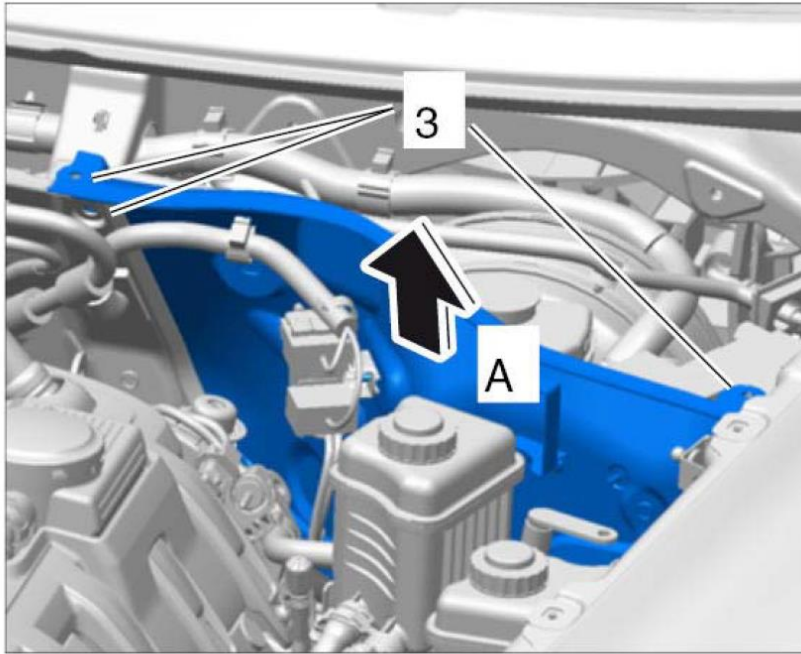

Courtesy of PORSCHE CARS NORTH AMERICA, INC.

6. Lift cross panel up and remove it -A- .

WM 508119 REMOVING AND INSTALLING CROSS PANEL > INSTALLING CROSS PANEL > INSTALLING LEFT CROSS PANEL

1. Push rubber seal -1- onto the bodyshell flange and center cross panel -A- .

2. Lightly coat the rubber seal with sliding compound, e.g. glycerine (to make it easier to refit the cross panel).

Fig 1: Pushing Rubber Seal Onto Bodyshell Flange And Centre Cross Panel

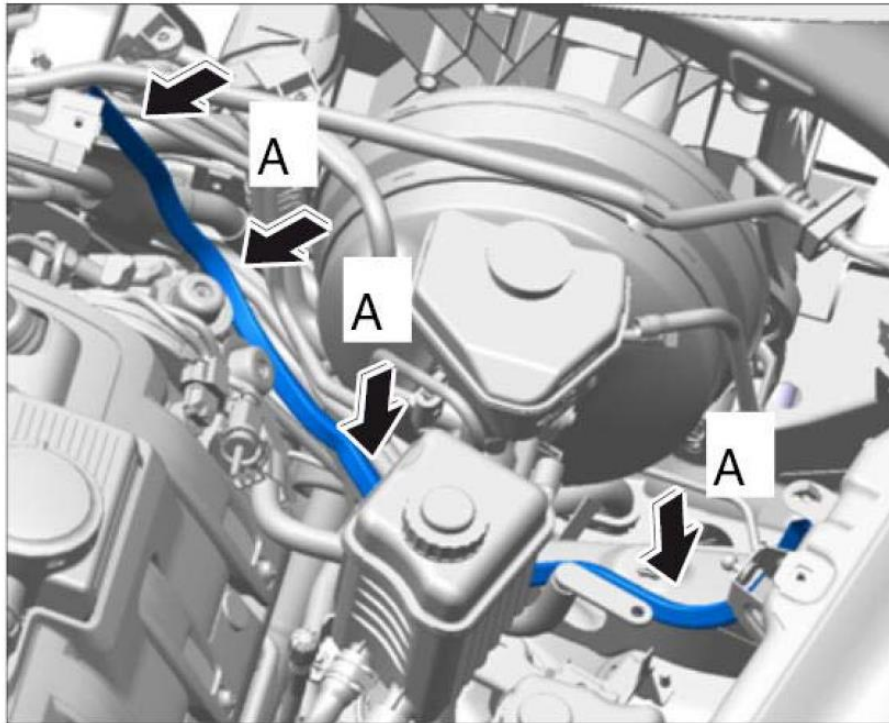

Courtesy of PORSCHE CARS NORTH AMERICA, INC.

2. Further installation of the left cross panel is performed in reverse order to removal.

WM 508119 REMOVING AND INSTALLING CROSS PANEL > SUBSEQUENT WORK

>

SUBSEQUENT WORK FOR LEFT CROSS PANEL

1. Install wind deflector cover. → INSTALLING COWL PANEL COVER - section on "Installing"
2. Install front cover (engine compartment) on the left. → INSTALLING FRONT TRIM PANEL (ENGINE COMPARTMENT) - section on "Installing"

WM 508119 REMOVING AND INSTALLING CROSS PANEL > SUBSEQUENT WORK

>

SUBSEQUENT WORK FOR RIGHT CROSS PANEL

1. Secure DME control unit. → INSTALLING DME CONTROL UNIT - section on "Installing"
2. Install cowl panel cover. → INSTALLING COWL PANEL COVER - section on "Installing"
3. Install front cover (engine compartment) at the right. → INSTALLING FRONT TRIM PANEL (ENGINE COMPARTMENT) - section on "Installing"