



# AfterSales Training

Cayenne Engine Repair – V8 and V6

**P10C**

# Porsche AfterSales Training

Student Name: \_\_\_\_\_

Training Center Location: \_\_\_\_\_

Instructor Name: \_\_\_\_\_

Date: \_\_\_\_\_

**Important Notice:** Some of the contents of this AfterSales Training brochure was originally written by Porsche AG for its rest-of-world English speaking market. The electronic text and graphic files were then imported by Porsche Cars N.A, Inc. and edited for content. Some equipment and technical data listed in this publication may not be applicable for our market. Specifications are subject to change without notice.

We have attempted to render the text within this publication to American English as best as we could. We reserve the right to make changes without notice.

© 2007 Porsche Cars North America, Inc. All Rights Reserved. Reproduction or translation in whole or in part is not permitted without written authorization from publisher. AfterSales Training Publications

Dr. Ing. h.c. F. Porsche AG is the owner of numerous trademarks, both registered and unregistered, including without limitation the Porsche Crest®, Porsche®, Boxster®, Carrera®, Cayenne®, Cayman™, Tiptronic®, VarioCam®, PCM®, 911®, 4S®, and the model numbers and distinctive shapes of Porsche's automobiles such as, the federally registered 911 automobile. The third party trademarks contained herein are the properties of their respective owners. Porsche Cars North America, Inc., believes the specifications to be correct at the time of printing. However, specifications, standard equipment and options are subject to change without notice.

<b>Description</b>	<b>Section</b>
Engine Type Designations . . . . .	1
Cayenne S and Turbo V8 Engines – 1st Generation . . . . .	2
Cayenne V6 Engine – 1st Generation . . . . .	3
Cayenne S and Turbo V8 Engines – 2nd Generation . . . . .	4
Cayenne V6 Engine – 2nd Generation . . . . .	5
Conversion Charts . . . . .	6



## Engine Type Designations

### Engine Number Identification

#### Cayenne S/T – V8

Digit: 1 2 3 4 5 6 7 8  
Example: 8 1 3 0 0 5 0 1  
Engine Type: (8 = 8 Cyl. Engine) \_\_\_\_\_  
Engine Version: \_\_\_\_\_  
Model Year: \_\_\_\_\_  
Serial Number: \_\_\_\_\_

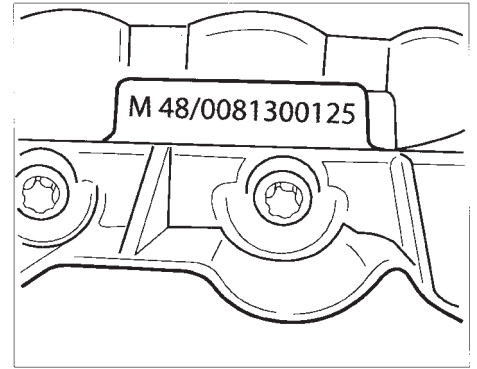

**V8** – The engine number is located on the bottom of the crankcase, left side (5-8 cylinder bank), by the oil pan sealing surface. **Note:** Underside paneling needs to be removed.

#### Cayenne – V6

Digit: 1 2 3 4 5 6 7 8  
Example: M 5 5 0 0 5 0 1  
Engine Version: \_\_\_\_\_  
Serial Number: \_\_\_\_\_

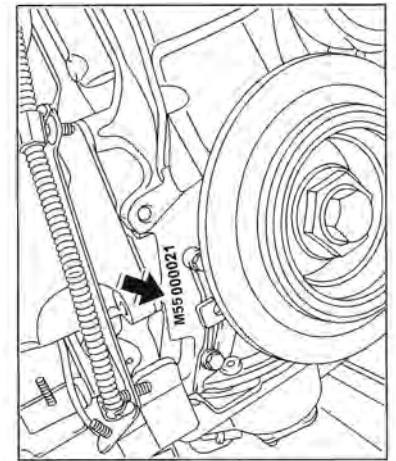

**V6** – The engine number is located on the front right of the crankcase next to the crankshaft pulley.

## Engine Type Designations

### Cayenne/S/T Engine Type Designations Since Model Year 2003

Model Year	Engine Type	Displ. Liters	Engine Power kW / HP	Installed In
2003	M48.00	4.5 V8	250/340	Cayenne S
	M48.50	4.5 V8	331/450	Cayenne Turbo
2004	M02.2Y (BFD)	3.2 V6	184/250	Cayenne
	M48.00	4.5 V8	250/340	Cayenne S
	M48.50	4.5 V8	331/450	Cayenne Turbo
2005	M02.2Y (BFD)	3.2 V6	184/250	Cayenne
	M48.00	4.5 V8	250/340	Cayenne S
	M48.50	4.5 V8	331/450	Cayenne Turbo
2006	M02.2Y (BFD)	3.2 V6	184/250	Cayenne
	M48.00	4.5 V8	250/340	Cayenne S
	M48.50	4.5 V8	331/450	Cayenne Turbo
2008	M55.01	3.6 V6	213/290	Cayenne
	M48.01	4.8 V8	283/385	Cayenne S
	M48.51	4.8 V8	358/500	Cayenne Turbo



<b>Subject</b>	<b>Page</b>
General .....	3
Cayenne S Engine Data .....	3
Cayenne Turbo Engine Data .....	4
Engine Mounts .....	4
Crankcase .....	5
Crankshaft, Vibration Damper .....	5
Cayenne S/T Pistons .....	6
Cayenne S/T Cylinder Head .....	7
Camshafts with Cylinder Specific Cam Contours .....	8
Chain Drive, Belt Drive .....	8
Camshaft Adjustment .....	9
Hydraulic Solenoid Valve .....	10
Cayenne S Oil Circulation .....	12
Cayenne Turbo Oil Circulation .....	13
Oil Spray Jets, Oil Pump .....	14
Cayenne S/T Crankcase Ventilation .....	15
Oil Filter .....	15
Oil Temperature and Level .....	16
Cooling System .....	17
Service Position & Engine Removal .....	20









## Crankcase

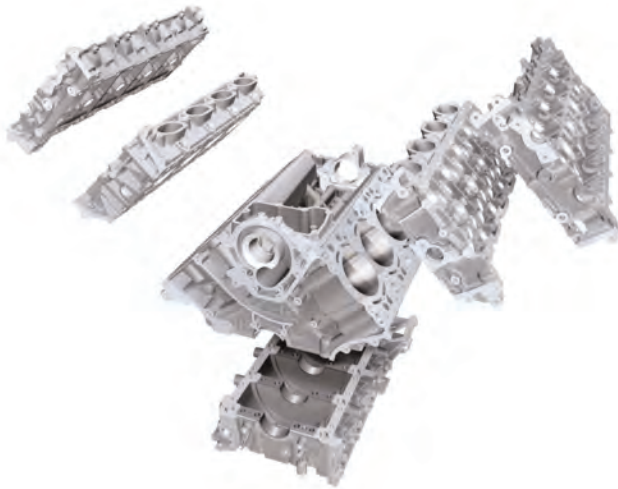

Engine Components

The crankcase in the Porsche Cayenne is a two-piece “closed deck” design, made of a light-weight alloy (AlSi17Cu4Mg). In closed deck construction, the sealing surface of the crankcase to the cylinder head is largely closed, only the bores and passages for oil and coolant are present. This design will strengthen the entire structure. The result is less cylinder distortion and benefits in oil consumption.

The alloy for the crankcase housing is a so-called hypereutectic alloy, in which silicon crystals are formed. To create a wear-resistant surface on the cylinder walls, these silicon crystals are uncovered by multiple special honing procedures. To minimize thermal changes in bearing clearance and thus reduce mechanical noise, the lower section of the crankcase is furnished with cast-in cast iron bearing blocks. Another advantage is that when the engine is at operating temperature, oil flow at the main bearings does not increase substantially as a result of the constant bearing clearance (approximately the same coefficient of thermal expansion between steel/crankshaft and cast iron/bearing block).

## Crankshaft



Crankshaft

The drop-forged crankshaft runs in five bearings and has eight counterweights. Main bearing number 3 is designed as a thrust bearing. Axial play is determined by two thrust washers, which are set into the bearing housing halves. The main bearings are dual material bearings and are 64 mm in diameter. The connecting rod bearings are triple material bearings and are 54 mm in diameter.

## Vibration Damper

A vibration damper is used to reduce torsional vibration at the crankshaft and additionally reduce component loads.



Vibration Damper

## Notes:

---

---

---

---

---

---

---

---

---

---





# Engine – Cayenne S/T – 1st Generation

## Camshafts with Cylinder Specific Cam Contours

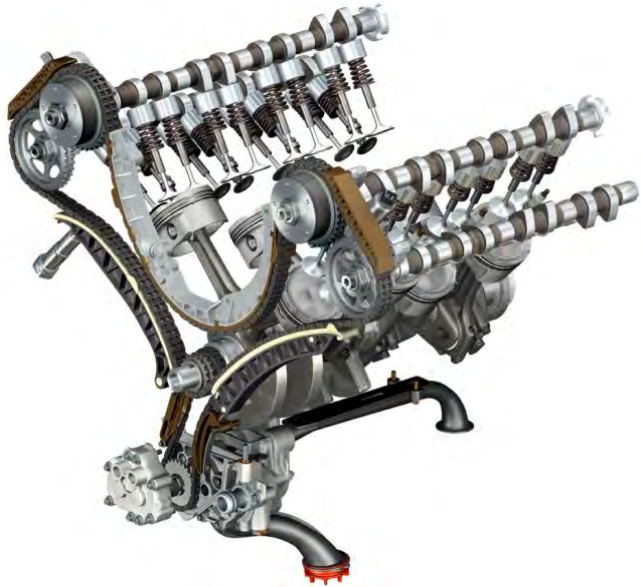

The intake and exhaust camshafts for both engine versions have a base diameter of 38 mm. Intake valve lift is 10 mm. Exhaust valve lift for cylinders 1, 2, 6 and 8 is 8 mm, for cylinders 3, 4, 5 and 7 exhaust valve lift is 9.85 mm.

The engine design with a V8 crankshaft and 90° throws ensures outstanding balancing of masses and forces. However, with this engine design and a layout with conventional cam contours (equal cam lift) individual cylinders would hamper each other as gas flows out into the exhaust manifold. The reason is that the exhaust lead impulse of the particular cylinder on the exhaust stroke (e.g. cylinder number 2) gets into the crossover phase of the following cylinder (cylinder number 3). This would have a detrimental effect on cylinder filling. In addition, excess residual gases have a negative effect on the knock limit. Because of the Cayenne's firing order (1 – 3 – 7 – 2 – 6 – 5 – 4 – 8), cylinders 3 and 4 as well as 5 and 7 would be at a disadvantage in their charge. These cylinders are given higher cam lift. This step achieves equal filling of the cylinders, which results in an optimized torque curve across the entire rpm range.

## Chain Drive

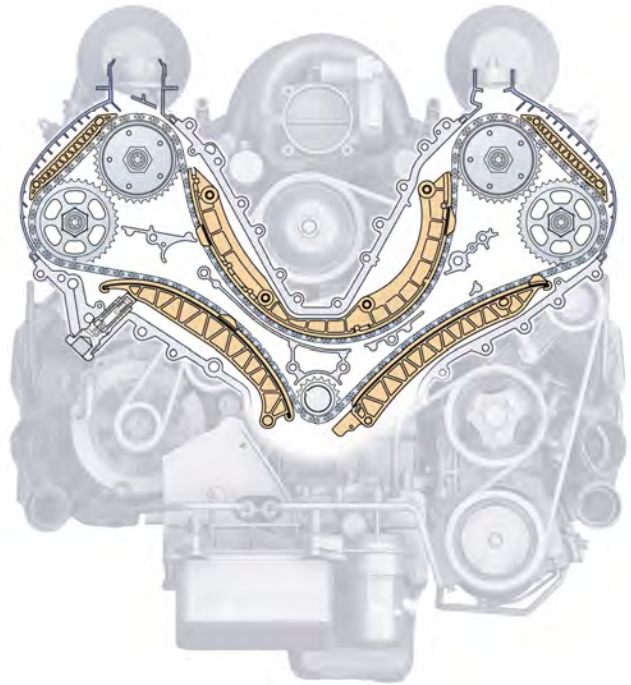

The chain drive consists of a duplex roller chain driving both intake and exhaust camshafts. The chain has specially coated guides. The lower guide on cylinder bank 1 – 4 is designed to be a tensioner at the same time. The chain tensioner is hydraulic and maintenance-free.

## Belt Drive

A poly-rib belt drives accessories such as the alternator, coolant pump, power steering pump and air-conditioning compressor by the vibration damper. A maintenance-free, hydraulic belt tensioner maintains correct tension.

## Notes:

---

---

---

---

---

---

---

---

---

---

**Camshaft Adjustment**

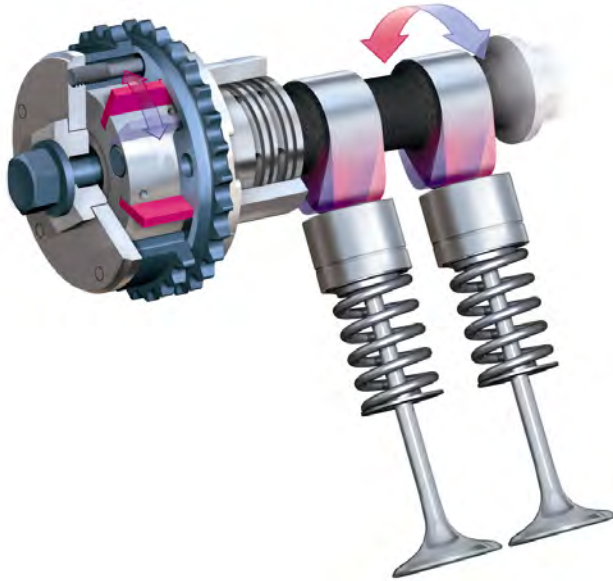

Camshaft adjustment at the intake camshaft is based on the operation of a vane-type adjuster. The DME control unit determines the current position of the camshaft to the crankshaft (actual angle) from the engine speed sensor and Hall sensor signals. The position control in the DME control unit determines the desired specified angle via the programmed map values (rpm, load, engine temperature). If there is a difference between the specified and actual angle, a regulator in the DME actuates a hydraulic solenoid valve according to the desired adjustment.

Adjustment angle is 50° crankshaft angle (25° camshaft angle).

**Notes:**

---

---

---

---

---

---

---

---

---

---

---

---

---

**Vane-Type Adjuster**

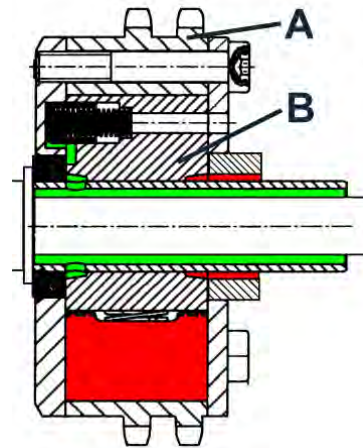

A - Stator  
B - Rotor

The vane-type adjuster consists of the stator (A), attached to the crankshaft through a sprocket, the rotor (B), attached to the camshaft; the vanes and two covers. The sprocket is attached to the outer diameter of the stator. It is a positive fit to the crankshaft through the chain drive. The rotor is bolted to the camshaft. Rotation between rotor and stator is possible (inner mounting of the adjuster). This rotation is limited by the vanes mounted in the rotor and by the stops on the stator. The vanes also divide each of the recesses on the stator into two chambers.

These chambers can be filled with oil through oil orifices and oil lines in the rotor. A cover attached to the sprocket seals the chambers laterally. The adjuster is locked to a stop (retard). To do this, a spring-loaded pin in the retard position of the adjuster moves into a hole in the cover. A positive connection is created between stator and rotor for starting the engine. This prevents noise during the time when the oil pump is starting to turn.

**Notes:**

---

---

---

---

---

---

---

---

---

---

---

---

---

# Engine – Cayenne S/T – 1st Generation

## Vane-Type Adjuster (cont'd)

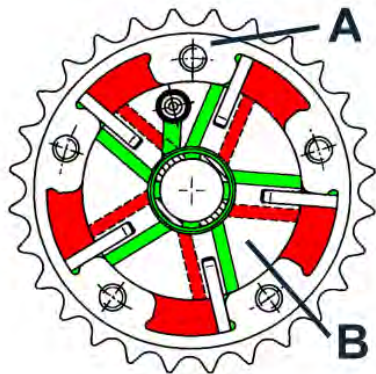

- A - Stator
- B - Rotor

### Operation

Two chambers acting in different directions are provided in the adjuster. Filling one chamber causes the rotor to rotate in one direction. By filling the other chamber, the rotor and the camshaft can be rotated back to its initial position. The oil from the non-pressurized chamber flows to the hydraulic solenoid valve back into the crankcase.

If the oil feed and the oil return at the hydraulic solenoid valve is interrupted while one chamber is being filled (middle position of the valve), the adjuster stops in the position it has just reached. The chambers lose oil due to leakage so that the adjuster leaves its position. The hydraulic solenoid valve is actuated accordingly through the DME and the adjuster returns to the desired position again.

### Hydraulic Solenoid Valve

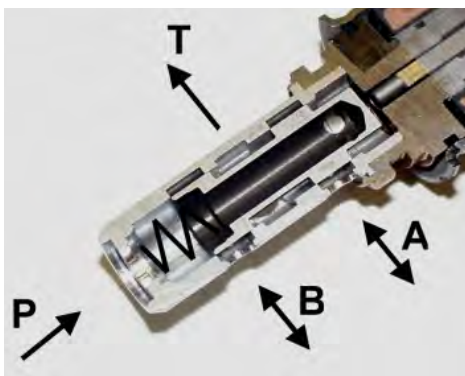

The hydraulic solenoid valve is designed as a four-way proportioning valve and, depending on the setting from the DME, opens one of the two control lines (A/B) to the oil

pressure supply line (P) and opens the other line to allow the oil to flow out to return to the crankcase (T-line). If oil pressure is applied to the A-line, the adjuster is rotated in the direction of early. If oil pressure is applied to the B-line, the adjuster is rotated in the direction of later timing. In the middle position both control lines are closed. The camshaft is held in the interim position.

So, it is not only possible to adjust the position very quickly, but also very slowly in the event of minor deviations of the valve from the middle position.

### Notes:

---

---

---

---

---

---

---

---

---

---

---

---

---

---

---

---

---

---

---

---

---

---

---

---

---

---





# Engine – Cayenne S/T – 1st Generation

## Cayenne S Oil Circuit

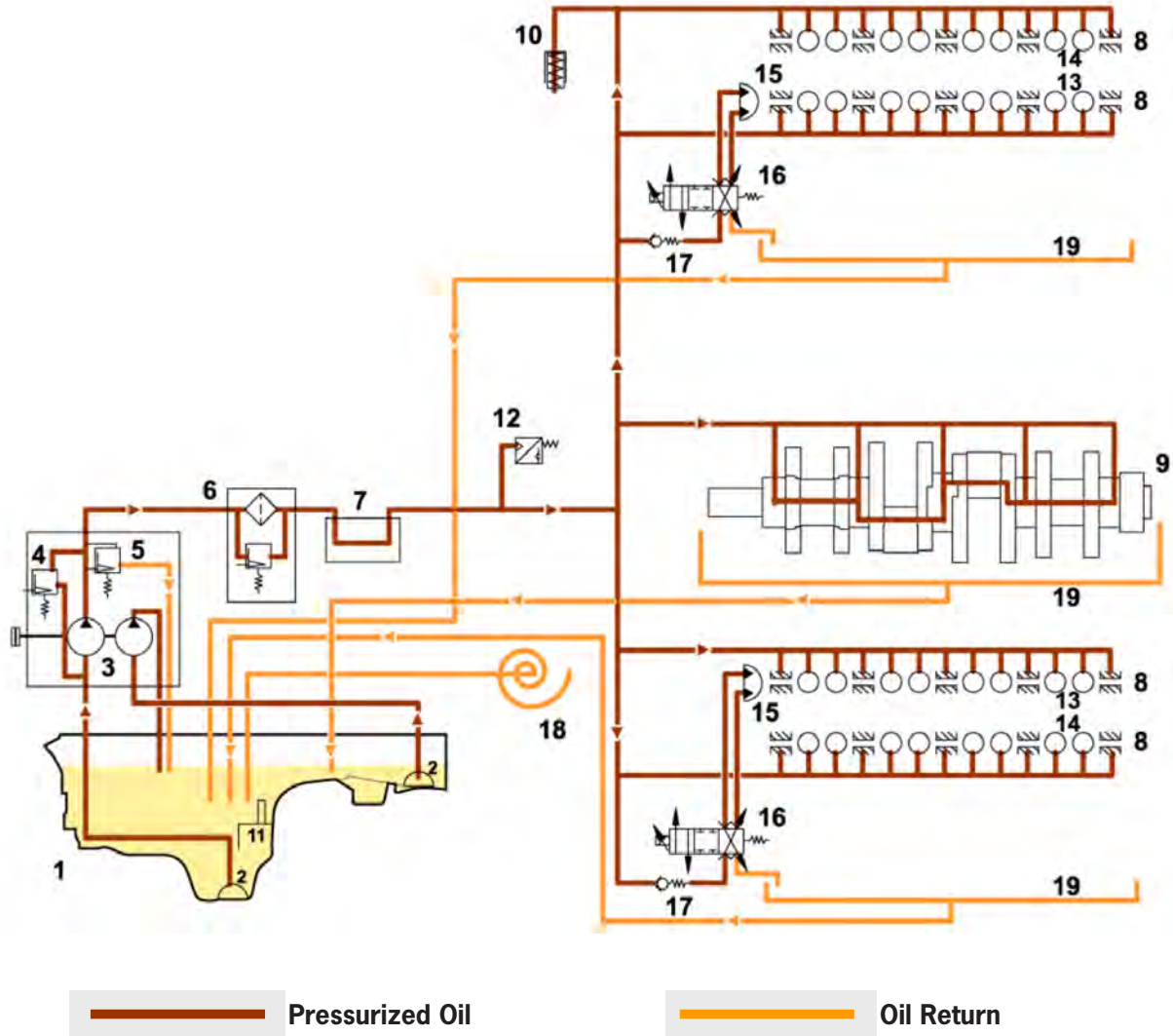

- |   |  |
|---|--|
| <ul style="list-style-type: none"> <li>1 - Oil pan</li> <li>2 - Suction tube with screen</li> <li>3 - Oil pumps</li> <li>4 - Control valve (regulates oil pressure to about 5 bar)</li> <li>5 - Safety valve (opens at 10 bar)</li> <li>6 - Full-flow oil filter with pressure relief valve</li> <li>7 - Oil to water heat exchanger</li> <li>8 - Camshaft</li> <li>9 - Crankshaft</li> <li>10 - Chain tensioner</li> </ul> | <ul style="list-style-type: none"> <li>11 - Oil level detector and oil temperature sensor</li> <li>12 - Oil pressure sensor</li> <li>13 - Hydraulic lifters, intake</li> <li>14 - Hydraulic lifters, exhaust</li> <li>15 - Camshaft adjuster</li> <li>16 - Hydraulic solenoid valve</li> <li>17 - Non-return valve</li> <li>18 - Oil mist separator</li> <li>19 - Oil return passages</li> </ul> |
|---|--|

## Cayenne Turbo Oil Circuit

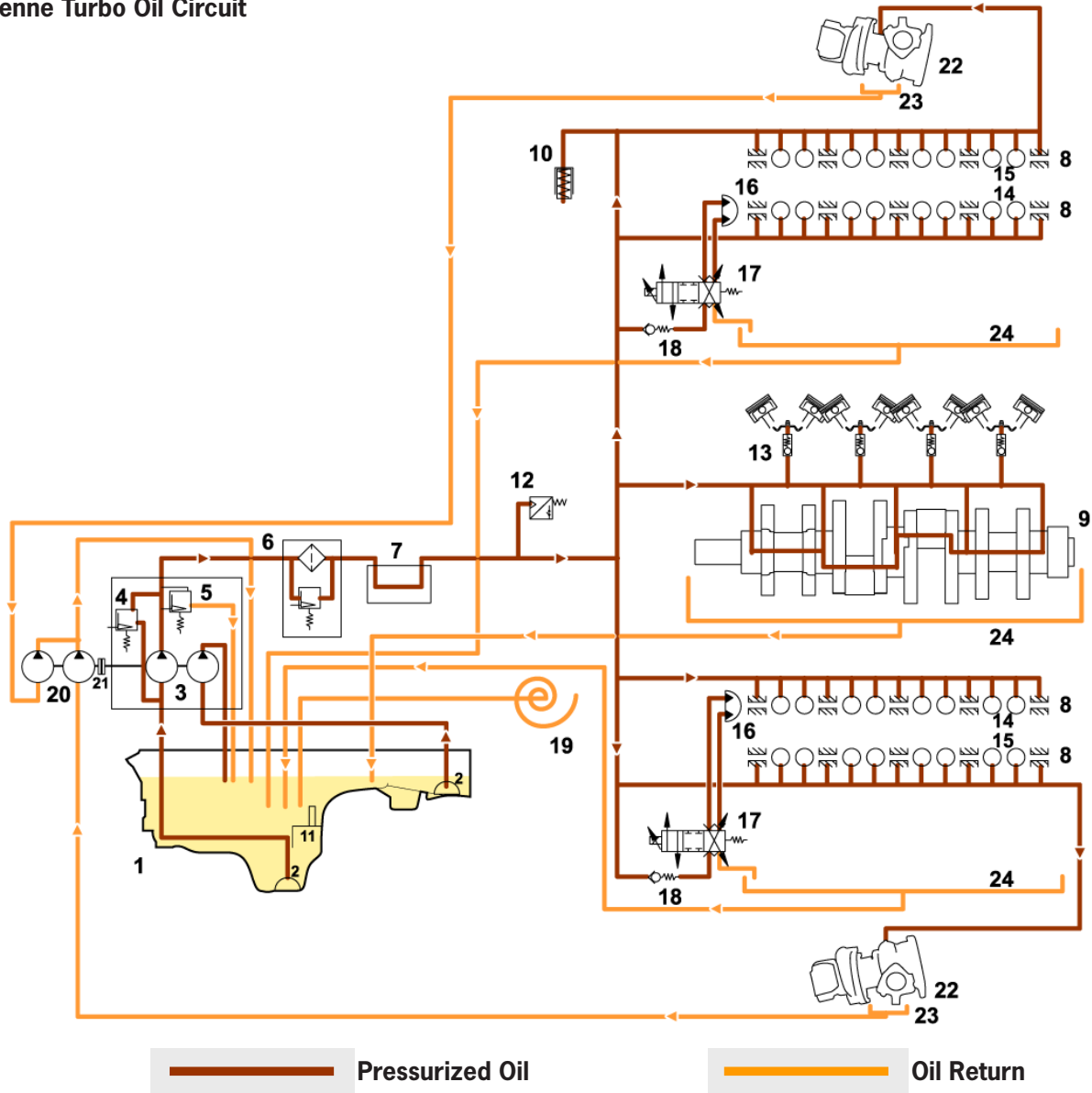

- |   |  |
|---|--|
| <ul style="list-style-type: none"> <li>1 - Oil pan</li> <li>2 - Suction tube with screen</li> <li>3 - Oil pumps</li> <li>4 - Control valve (regulates oil pressure to about 5 bar)</li> <li>5 - Safety valve (opens at 10 bar)</li> <li>6 - Full-flow oil filter with pressure relief valve</li> <li>7 - Oil to water heat exchanger</li> <li>8 - Camshaft</li> <li>9 - Crankshaft</li> <li>10 - Chain tensioner</li> <li>11 - Oil level detector and oil temperature sensor</li> <li>12 - Oil pressure sensor</li> </ul> | <ul style="list-style-type: none"> <li>13 - Piston oil spray nozzle (opening pressure 1.8 bar)</li> <li>14 - Hydraulic lifter, intake</li> <li>15 - Hydraulic lifter, exhaust</li> <li>16 - Camshaft adjuster</li> <li>17 - Hydraulic solenoid valve</li> <li>18 - Non-return valve</li> <li>19 - Oil mist separator</li> <li>20 - Suction pump, turbocharger</li> <li>21 - Equalizer clutch</li> <li>22 - Turbocharger</li> <li>23 - Suspended oil container</li> <li>24 - Oil return passages</li> </ul> |
|---|--|





# Engine – Cayenne S/T – 1st Generation

## Oil Level and Temperature Sensor

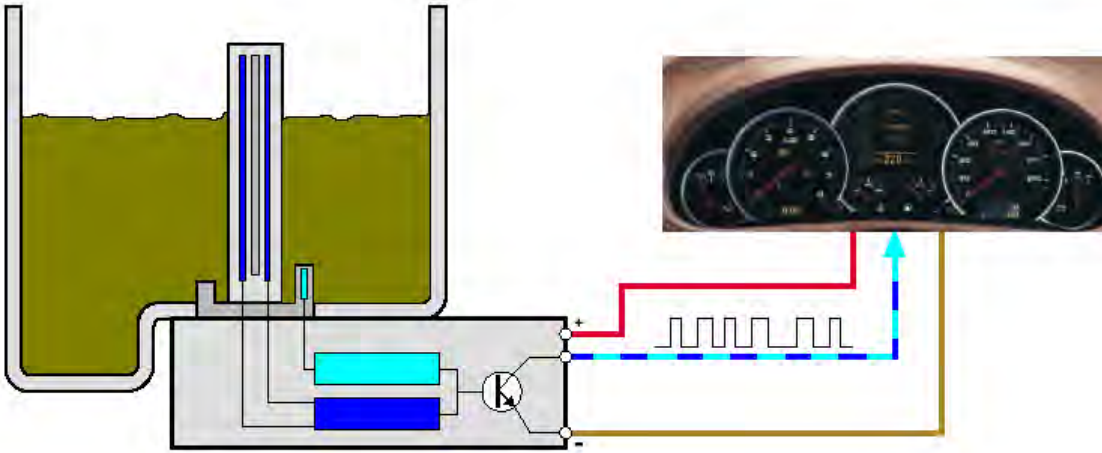

The Cayenne uses a new oil level and temperature sensor. The sensor bolts into the oil pan and sends oil level and temperature information to the instrument cluster.

The oil level/oil temperature sender is a thermal oil level sensor. While the engine is running, the engine oil temperature is continuously measured and the engine oil level is calculated. Both parameters are sent via a common pulse-width modulated signal to the instrument cluster.

A separate temperature sensor with integrated electronics detects the oil temperature. The measuring element for oil level also works with temperature measurement. The electronics therefore heat it up quickly above the current oil temperature. After the heater voltage is switched off, the measuring element is cooled down by the engine oil to the oil temperature level. The oil level is calculated from the length of time of the cooling phase.

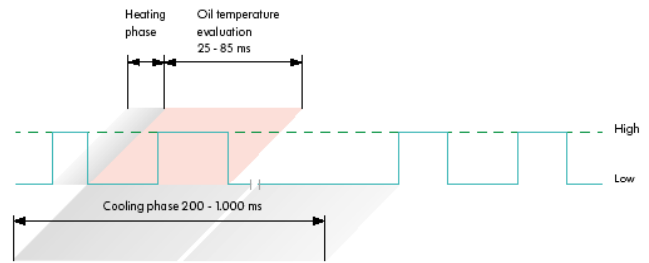

The signal indicates the heating phase as high voltage and the cooling phase as low voltage. During the cooling phase, engine oil temperature information is transferred as a separate high signal.

### Notes:

---



---



---



---



---



---



---



---



---



---



---

long cooling phase	low oil level
short cooling phase	normal



# Engine – Cayenne S/T – 1st Generation

## Cayenne S Coolant Circulation

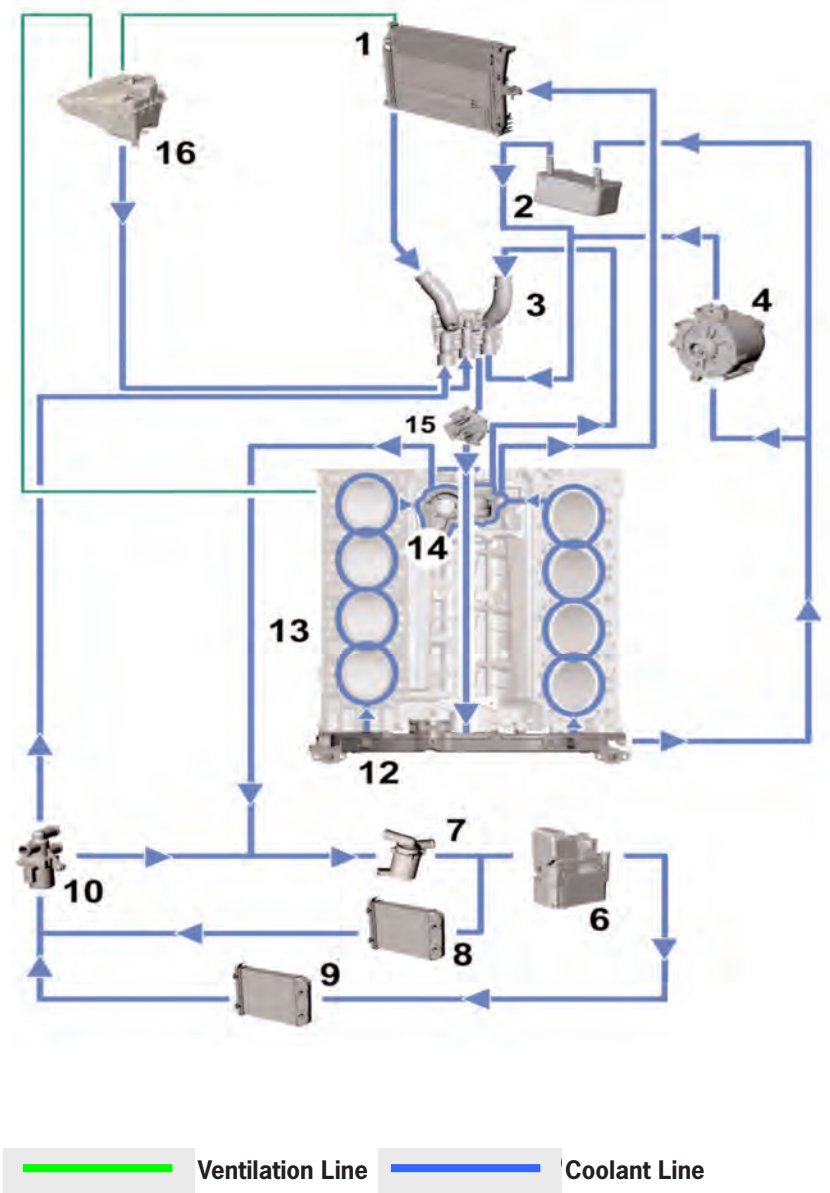

- 1 - Radiator
- 2 - Oil to water heat exchanger
- 3 - Thermostat housing
- 4 - Alternator
- 6 - Auxiliary heating
- 7 - Electrical run-on pump
- 8 - Rear heater core
- 9 - Front heater core
- 10 - 3/2-way valve
- 12 - Coolant distribution pipe
- 13 - Engine
- 14 - Coolant collection pipe
- 15 - Water pump
- 16 - Coolant overflow reservoir



Cayenne Turbo Coolant Circulation

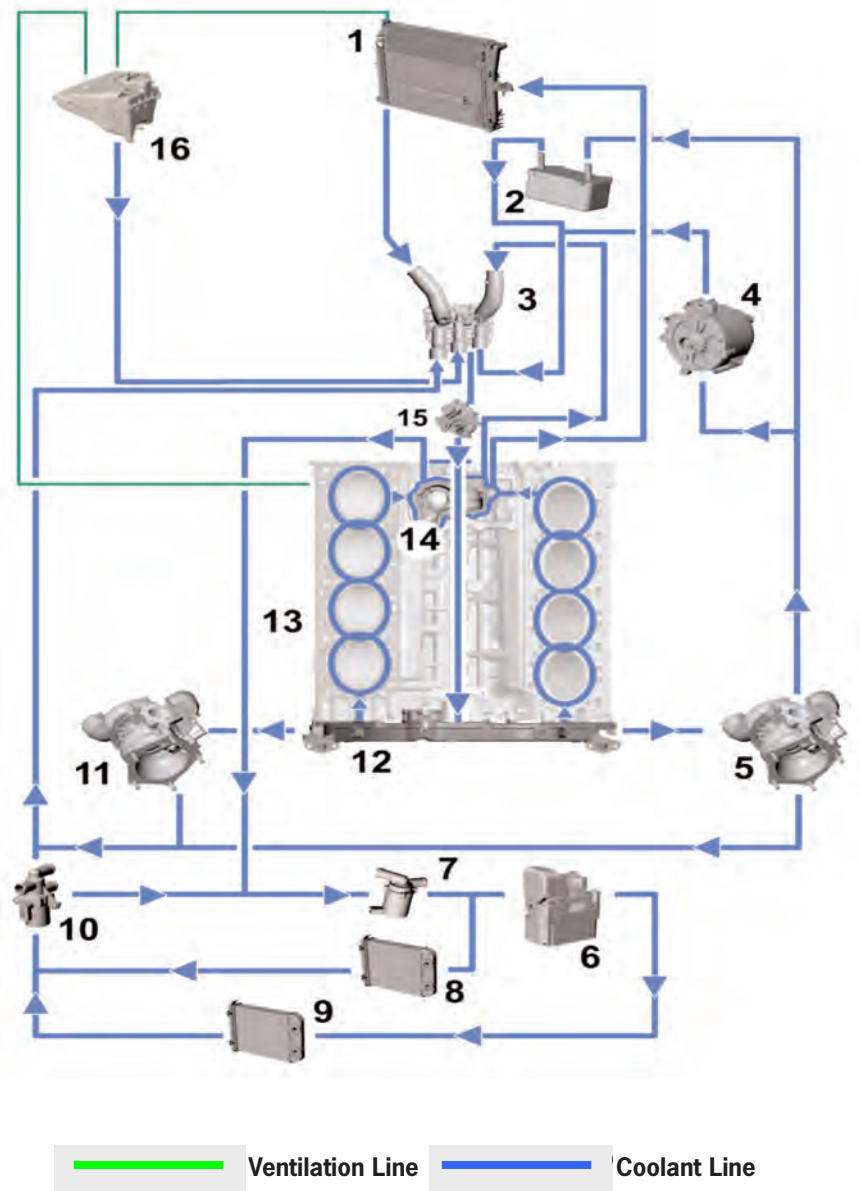

- 1 - Radiator
- 2 - Oil to water heat exchanger
- 3 - Thermostat housing
- 4 - Alternator
- 5 - Exhaust turbocharger
- 6 - Auxiliary heating
- 7 - Electrical run-on pump
- 8 - Rear heater core
- 9 - Front heater core

- 10 - 3/2-way valve
- 11 - Exhaust turbocharger
- 12 - Coolant distribution pipe
- 13 - Engine
- 14 - Coolant collection pipe
- 15 - Water pump
- 16 - Coolant overflow reservoir





<b>Subject</b>	<b>Page</b>
General .....	3
Cayenne Engine Data .....	3
Crankcase, Crankshaft .....	4
Vibration Damper .....	5
Connecting Rods and Pistons .....	5
Cylinder Head .....	5
Cylinder Head Gasket .....	6
Timing With Variable Camshaft Control .....	6
Camshafts .....	7
Belt Drive .....	10
Belt Tensioner .....	10
Oil Lubrication System .....	11
Oil Pump and Oil Pan .....	12
Crankcase Ventilation .....	13
Oil Filter .....	13
Cooling System .....	14



## Engine – Cayenne (V6) – 1st Generation



### General

In addition the 4.5 liter V8 naturally-aspirated and turbo engines, the Porsche Cayenne now has a third engine option. The 3.2 liter V6 gasoline engine offers a wide engine speed range with high power output and the long stroke creates high torque at low RPMs while maintaining good consumption and emission values.

Important features of the engine are:

- Weight-optimized grey cast iron crankcase (15° V)
- One-piece die-cast aluminum cylinder head
- Four valves per cylinder, operated via roller cam followers
- Continuously variable intake/exhaust camshaft timing
- Wet-sump lubrication
- Oil-spray piston cooling
- Oil-to-coolant heat exchanger
- Inclinations up to 45° to all sides possible
- Longitudinal cooling flow of cylinder head and crankcase

### Full-load Curve Cayenne

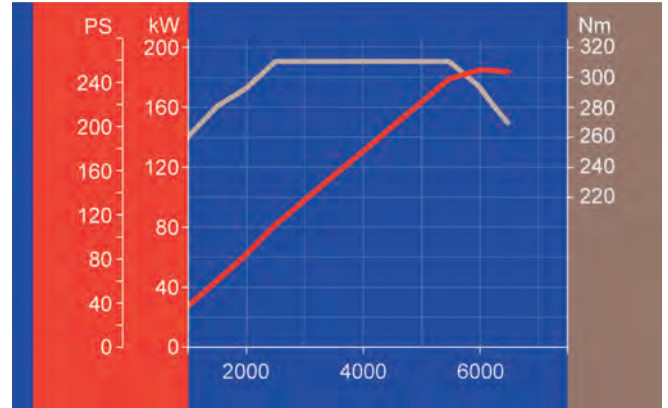

### Engine Data

Engine Type	M02.2Y (BFD)
No. of Cylinders	6
Bore	84.0 mm
Stroke	95.9 mm
Displacement	3.2 Liter
Compression Ratio	11.5
Max. Power	250 HP (184 kW)
At Engine Speed	6000 rpm
Max. Torque	229 ft lb (310 Nm)
At Engine Speed	2500 - 5500 rpm
Governed Speed	6700 rpm
Engine Weight with M/T	423 lbs (192 kg) (w/dual-mass flywheel, w/o clutch)
Engine Weight (Tiptronic)	397 lbs (180 kg) (with converter plate)
Firing Order	1 - 5 - 3 - 6 - 2 - 4

### Notes:

---



---



---



---



---



---



---



---



---



---



---

# Engine – Cayenne (V6) – 1st Generation

## Crankcase

The weight-optimized crankcase with the cylinders is manufactured from grey cast iron. The cylinders are arranged in a “V” at an angle of 15°, cylinder number 1 is located on the front passenger side. Bores are at 7.5° to gasket face.



Arrow shows the direction of travel.

## Crankshaft

The drop-forged crankshaft is carried on seven bearings. Main bearing number 4 is designed as an axial-thrust bearing. The axial clearance is determined by two axial-thrust washers, which are seated in the bearing pedestal. The bimetal main bearings have a diameter of 60 mm.



Main bearing cap number 4.

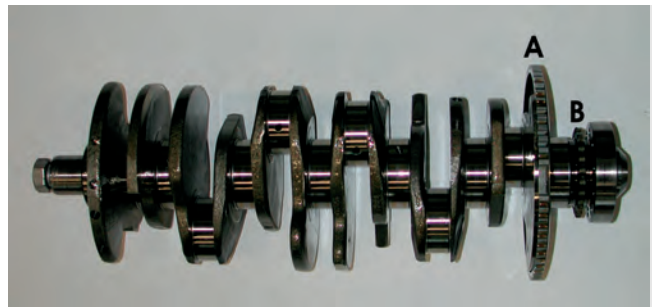

The pulse generator wheel for the engine speed and reference mark sender (A) along with the chain drive sprocket for the intermediate shaft (B) are on the crankshaft.

## Notes:

---

---

---

---

---

---

---

---

---

---

---

---

---

---

---

---

---

---

---

---

---

---

---

---

---

## Engine – Cayenne (V6) – 1st Generation

### Bearing Assignment

Markings are provided on both the crankcase and the crankshaft to indicate which bearing tolerances are installed.



### Torsional Vibration Damper

A torsional vibration damper is used to reduce torsional vibration at the crankshaft reduce component stress.

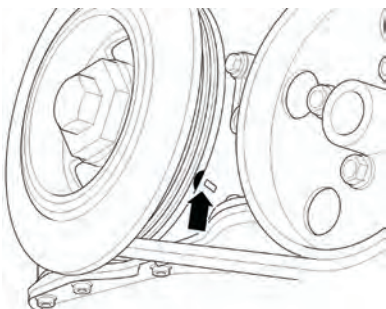

The torsional vibration damper has a TDC marking (arrow).

### Connecting Rods and Pistons

The connecting rod upper and lower halves each have a pairing number and are secured with reamed bolts. The bimetal connecting rod bearings have a diameter of 54 mm.



The pistons are alloy cast and are Graphal coated on the sliding surfaces to reduce noise. The full-floating wrist pin is lubricated with oil spray.

### Cylinder Head

The cylinder head is manufactured in one-piece from die-cast aluminum. The timing of the charge exchange takes place through four valves per cylinder, which are operated via roller cam followers with hydraulic valve clearance adjusters. The two intake and two exhaust valves are arranged in a "V" at a valve angle of 42.5°. The diameter of the valve head is 33.2 mm on the intake side and 30.2 mm on the exhaust side.

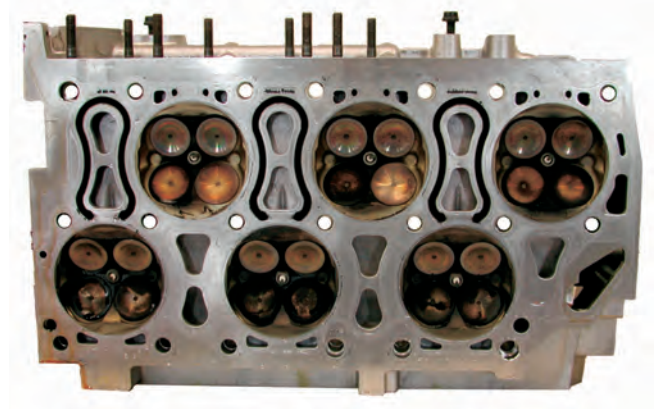

Cayenne V6 Cylinder Head













**Oil Lubrication System**

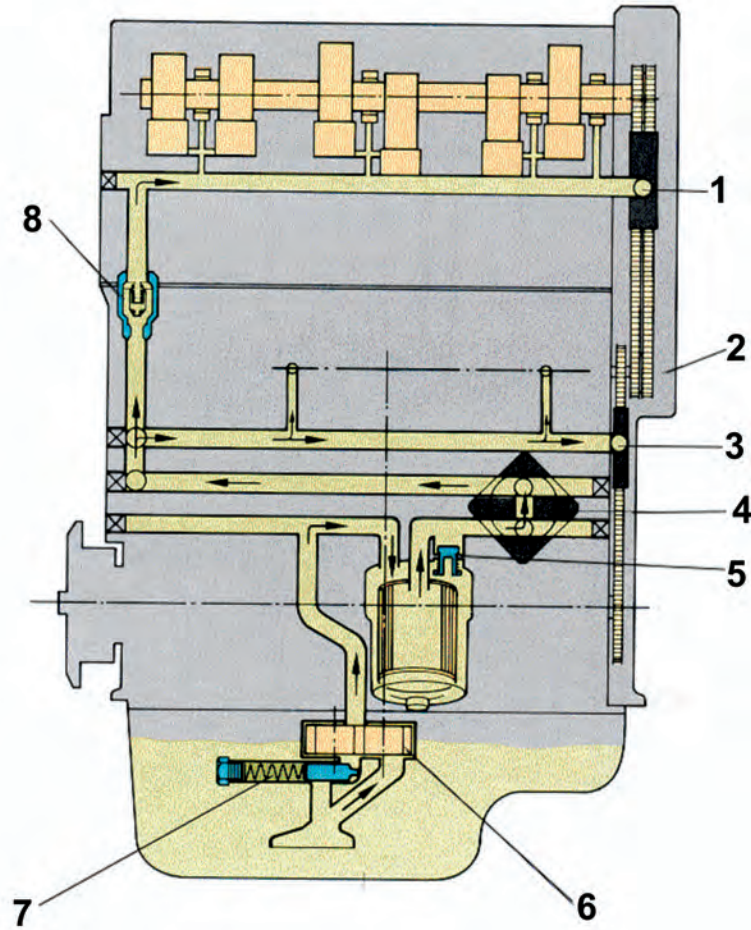

- 1 - Upper chain tensioner
- 2 - Intermediate shaft
- 3 - Lower chain tensioner
- 4 - Oil-to-water heat exchanger
- 5 - Bypass valve
- 6 - Oil pump
- 7 - Pressure relief valve (opens at 5.5 bar)
- 8 - Oil retaining valve

**Notes:**

---



---



---



---



---



---



---



---



---



---



---

## Engine – Cayenne (V6) – 1st Generation

### Oil Pump

The oil pump is a gear-type pump. The casing also contains the oil pressure control valve, which opens at 80 psi (5.5 bar).



Oil Pump

The oil pump is driven via a chain drive from the crankshaft to the intermediate shaft (1) and from there via a right-angle drive to shaft (3). The oil pump drive shaft (2) is hexagonal at both ends and drives the oil pump gear. The casing is closed and sealed by the cover (4). The cover also serves as a mount for the shaft (3).

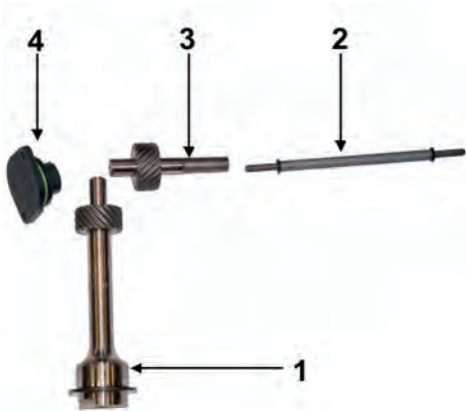

Oil Pump Drive

### Notes:

---

---

---

---

---

---

---

---

---

---

---

### Oil Pan



Oil Pan

The Porsche Cayenne V6 has a wet-sump lubrication system developed for reliable operation under extreme conditions, as well as off-road capability at inclinations up to 45° to all sides. For this reason, the oil pan shape and the form of the ribs and oil baffles have been optimized to ensure a constant oil return to the oil pump at 45° inclinations and to minimize oil foaming through spraying oil and churning losses.

### Oil Level Warning

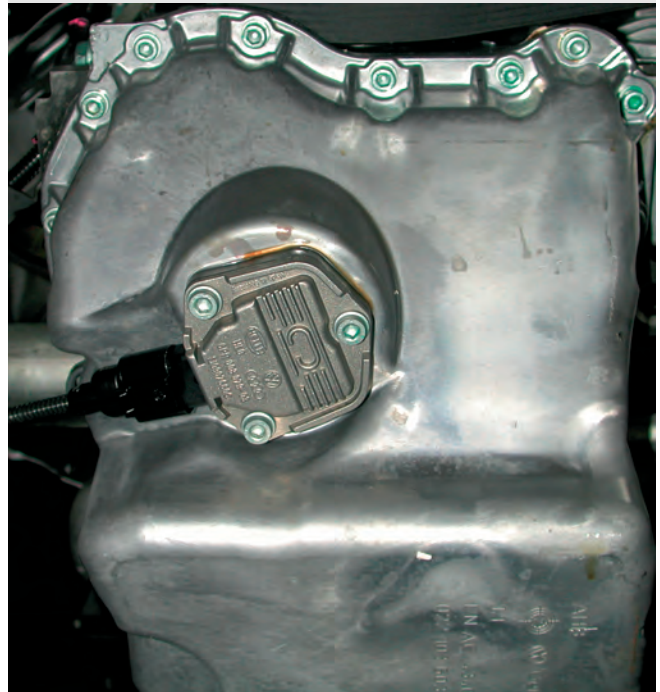

Oil Level Warning Sensor

An oil level warning device is fitted at the bottom of the oil pan. If the oil level drops too low, this is indicated on the instrument cluster with the appropriate warning.

### Oil Pressure Switch

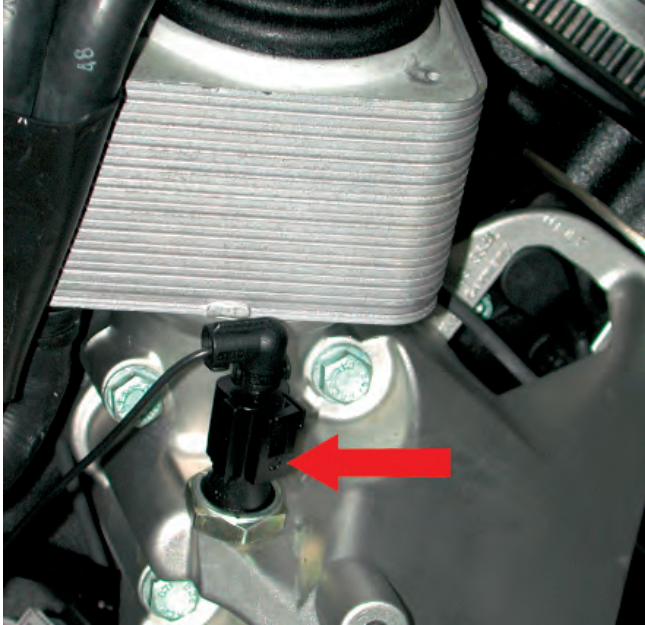

Oil Pressure Switch (Arrow)

The oil pressure switch is located on the oil filter bracket and indicates on the instrument cluster if the oil pressure falls below a specified value.

### Oil-Spray Piston Cooling

The Cayenne engine has oil-spray piston cooling to reduce the piston temperature. The spray jets are located in the main bearing pedestals. To ensure that the engine oil pressure is maintained at low engine speeds and high engine oil temperatures, the jets have an opening pressure of 29 psi (2 bar).

### Crankcase Ventilation

Crankcase ventilation takes place via the timing case cover in the rocker cover. Design of the timing case cover prevents oil from being pulled along over the timing chain. This pre-separation of the engine oil relieves the load on the ventilation system.

The oil vapor is also channeled through a stabilizing chamber in the rocker cover. At this point the engine oil is separated via an integrated condensation chamber. From there, the crankcase gases are channeled via a pressure control valve to the throttle valve of the intake system. To prevent freezing of the gases at extremely cold temperatures and high humidity levels, the inlet into the intake manifold is heated depending on the outside temperature.

This ensures effective operation of the ventilation system throughout the entire operational range of the engine, including under extreme off-road conditions at inclinations of up to 45°.

### Oil Filter

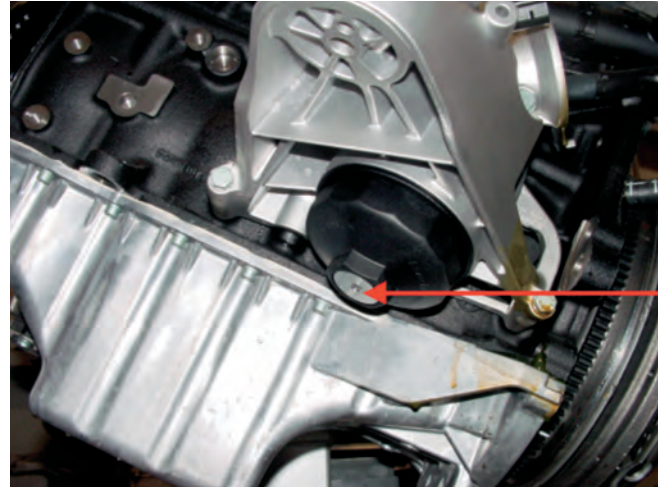

Oil Filter Cartridge Drain Plug (Arrow)

The oil filter is in the form of a replaceable filter cartridge. This is located on the mounting bracket and is removed from below. The oil can be drained from the cartridge via a drain plug.

Oil change volume without filter is 6.3 qts. (5.7 liters), 7 qts. (6.3 liters) with filter.

### Notes:

---

---

---

---

---

---

---

---

---

---

---

---

---

---

---

---

# Engine – Cayenne (V6) – 1st Generation

## Cooling System

- 1 - Expansion tank
- 2 - Throttle valve element
- 3 - Thermostat
- 4 - Coolant drain screw
- 5 - Oil-to-water heat exchanger
- 6 - Radiator with fan
- 7 - Crankcase vent
- 8 - Coolant pump

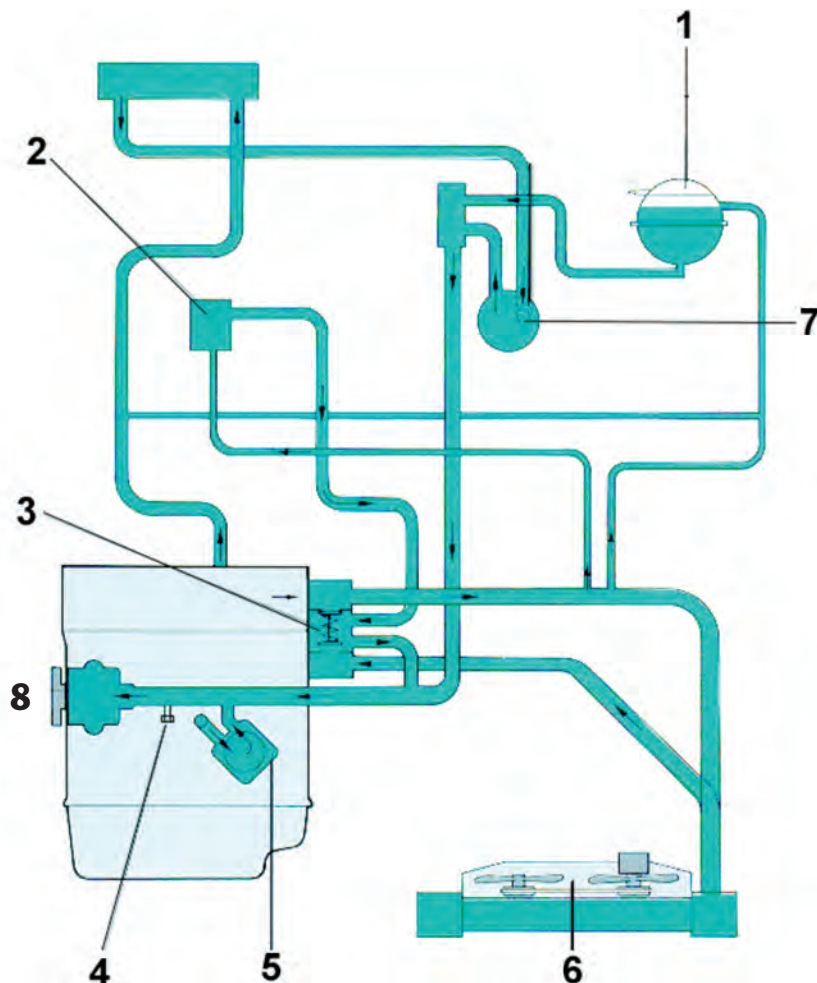

Coolant is passed from the coolant pump via the crankcase to the cylinder head. The coolant flows through the cylinder head longitudinally. From the cylinder head coolant flows to the thermostat housing, when the thermostat is closed, directly back to the coolant pump. At temperatures  $> 176^{\circ}\text{F}$ . ( $80^{\circ}\text{C}$ ), the coolant is directed through the radiator at the front of the vehicle and back to the pump.

The coolant pump has been appropriately adapted with regard to efficiency and flow to cope with the high thermal loading of the cooling circuit when towing a trailer in hot climates. To ensure even distribution of temperature in the engine, the coolant, depending on the engine temperature, continues to be circulated by an electric post-run coolant pump according to the load profile present before the engine was switched off.

The coolant (identical to Cayenne S and Cayenne Turbo) is intended to be a lifetime fill and therefore does not require replacement. The filling capacity is approx. 14 - 20 qts. (13 - 18 liters) depending on equipment.

### Notes:

---

---

---

---

---

---

---

---

---

---

---

---

---

---

---

---

---

---

---

---

---

---

---

---





<b>Subject</b>	<b>Page</b>
General .....	3
Cayenne S Engine Data .....	3
Cayenne Turbo Engine Data .....	4
Crankcase .....	4
Crankshaft .....	5
Torsional Vibration Balancer .....	5
Connecting Rods .....	5
Pistons .....	6
Cylinder Head .....	6
Valves, Valve Springs .....	10
Vacuum Pump .....	11
Belt Drive .....	11
Oil Lubrication System .....	13
Cayenne S Cooling System .....	17
Cayenne Turbo Cooling System .....	18



# Engine – Cayenne S/T – 2nd Generation

## 1 - Engine M 48.01/51

### General

Completely new engines have been developed for the Cayenne S and Cayenne Turbo for the 2008 model year.

### The main development aims were:

- More power and torque, while at the same time,
- Improving fuel economy and,
- Reducing the weight of the engine compared to previous engines.



**These development aims have essentially been achieved due to the following enhancements and new technologies:**

- Larger displacement
- Direct fuel injection (DFI)
- Sport button as standard
- VarioCam Plus
- Demand controlled oil pump

### Cayenne S Full Load Curve

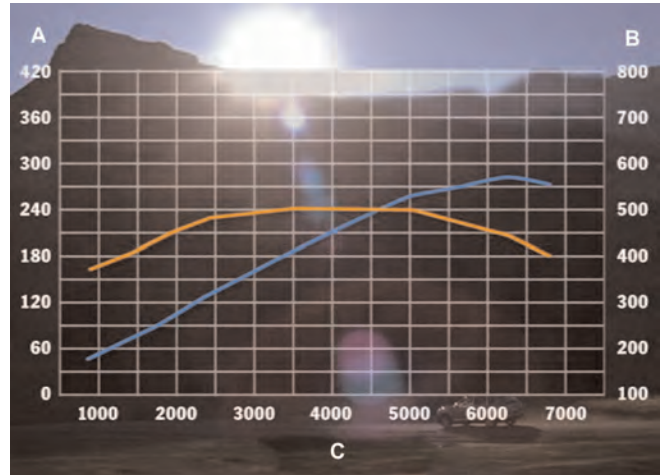

A - Power rating in kW  
 B - Torque in Nm  
 C - Engine speed

### Engine Data – Cayenne S

Engine Type	.....M48.01
No. of Cylinders	.....8
Bore	.....96 mm
Stroke	.....83 mm
Displacement	.....4.8 Liter
V-angle	.....90
Compression Ratio	.....12.5
Max. Output	.....385 HP (283 kW)
At Engine Speed	.....6200 rpm
Max. Torque	.....370 ftlb. (500Nm)
At Engine Speed	.....3500 rpm
Governed Speed	.....6700 rpm
Engine Weight (manual transmission)	.....503 lbs (228 kg)
Engine Weight (Tiptronic transmission)	.....456 lbs (217 kg)
Firing Order	.....1-3-7-2-6-5-4-8

### Notes:

---



---



---



---



---



---



---



---



---



---

# Engine – Cayenne S/T – 2nd Generation

## Cayenne Turbo Full Load Curve

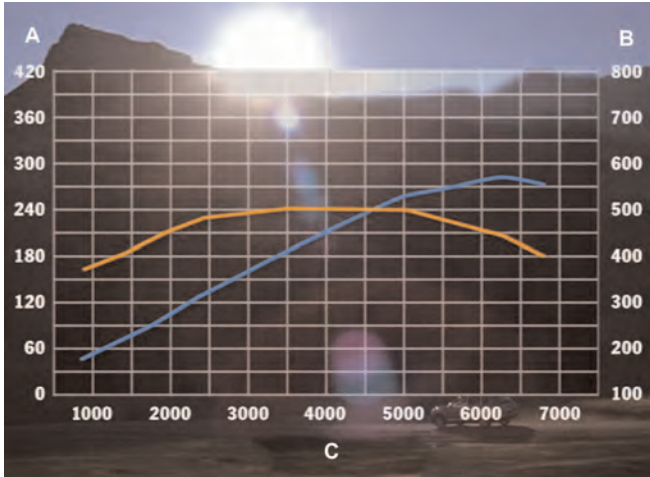

A - Power rating in kW  
B - Torque in Nm  
C - Engine speed

## Engine Data – Cayenne Turbo

Engine Type	.M48.51
No. of Cylinders	.8
Bore	.96 mm
Stroke	.83 mm
Displacement	.4.8 Liter
V-angle	.90
Compression Ratio	.10.5
Max. Output	.500 HP (358 kW)
At Engine Speed	.6000 rpm
Max. Torque	.518 ftlb. (700Nm)
At Engine Speed	.2250-4500 rpm
Governed Speed	.6700 rpm
Engine Weight	.520 lbs (236 kg)
Firing Order	.1-3-7-2-6-5-4-8

## Notes:

---

---

---

---

---

---

---

---

---

---

---

## Crankcase

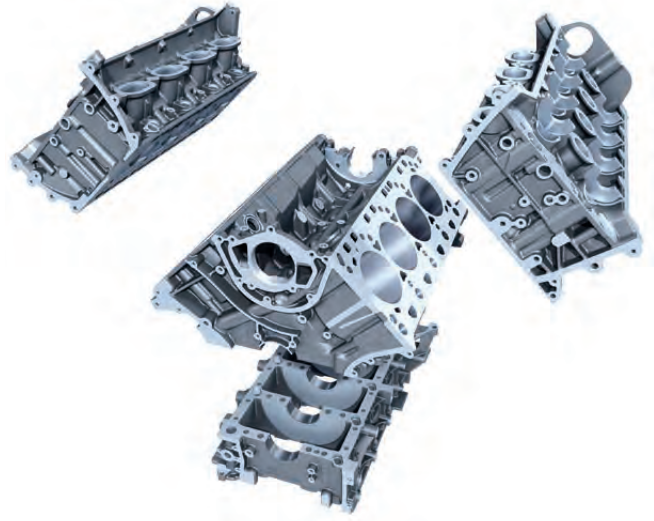

The crankcase in the Porsche Cayenne S and Cayenne Turbo is designed as a two-piece closed-deck component in a light metal alloy (AlSi17Cu4Mg). In the closed-deck design, the sealing surface of the crankcase is, for the most part, closed to the cylinder head, only the bores and channels for oil and coolant are exposed. The entire structure is additionally strengthened as a result of this design. This leads to less cylinder distortions and helps to reduce oil consumption.

The alloy used for the crankcase is known as a hypereutectic alloy in which silicon crystals form. These silicon crystals are exposed using several specialized honing processes in order to make the surface more durable. The crankcase has been lowered by 20 mm compared to the previous engine. As a result, the coolant pump and thermostat housing cover are also 20 mm lower and a modified water flow circuit was required.

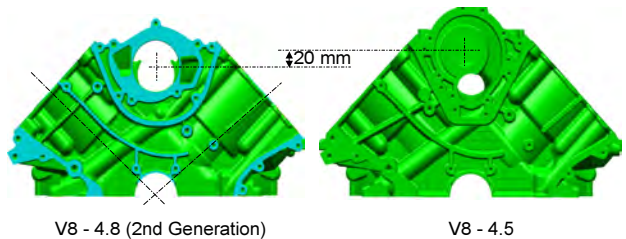

## Torsional Vibration Balancer



A torsional vibration balancer is used to reduce torsional vibrations on the crankshaft and to minimize component stress, e.g. on the belt drive. A shock absorber with the very best damping characteristics was selected because of the greater power impulses associated with direct fuel injection engines.

The viscous shock absorber has a floating flywheel in silicon oil in the housing. This allows the counter movement of the bearing mass to a not quite evenly rotating crankshaft.

## Connecting Rods

Compared to the 4.5 liter engine, the connecting rods are 2.4 mm longer. This reduces piston lateral runout and is more efficient. The connecting rod bearings are “lead-free” three-component bearings with a diameter of 54 mm. Oil is supplied to the connecting rod bearings via a Y-bore in the crankshaft.

## Notes:

---

---

---

---

---

---

---

---

---

---

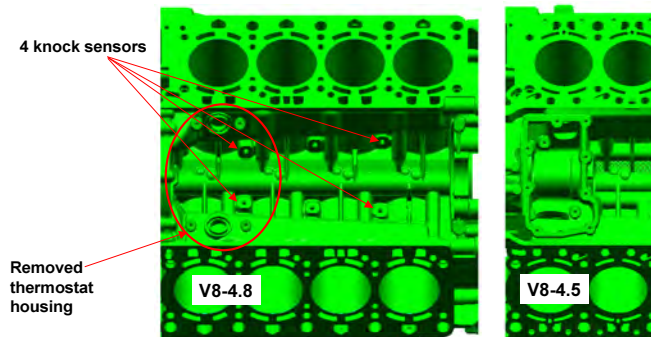
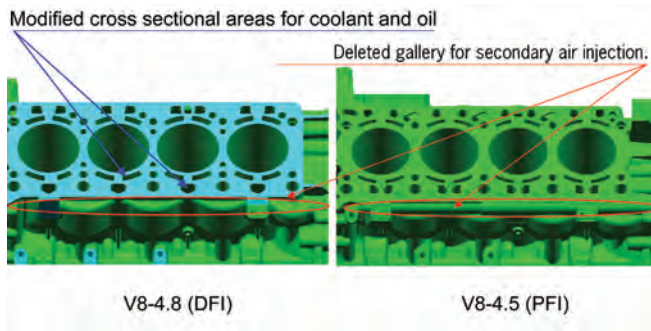

The lower part of the crankcase is machined and paired together with the upper part. To keep the weight as low as possible, the spheroidal graphite iron inserts are no longer used and the wall thickness has been reduced.

A low-pressure chill-casting procedure is used to make the upper and lower part of the crankcase.

## Crankshaft



The drop-forged crankshaft runs in five bearings and has eight counterweights. Main bearing 3 is designed as a thrust bearing. Axial play is determined by two thrust washers, which are inserted into the bearing halves. The main bearings are two-component bearings and have a diameter of 64 mm. Since the lower part of the crankcase is made of an all aluminum alloy, the main bearings are stronger than those used previously and the retaining lugs have been changed to avoid confusion. The main bearings are also “lead-free.”

# Engine – Cayenne S/T – 2nd Generation

## Pistons

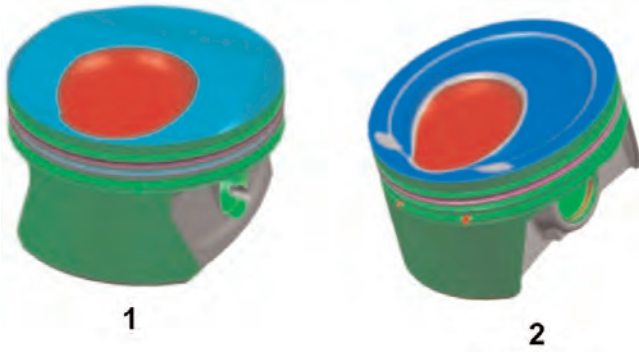

1 - Piston (naturally aspirated engine)  
2 - Piston (turbo engine)

The pistons are designed as recessed pistons made of aluminum alloy. They have an iron coating (Ferrocut) at the sides to improve friction characteristics. The pistons are different on cylinder bank 1 and 2 both in the Cayenne S and Cayenne Turbo. Another difference between the pistons in the Cayenne S and Cayenne Turbo is that the combustion cavities have different depths because the compression ratios of both engines are different. The piston ring packages for the turbo and naturally aspirated engines are the same.

## Cylinder Head

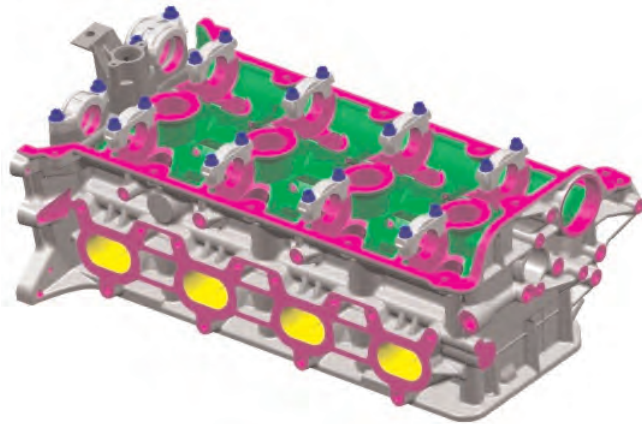

The cylinder head and camshaft mount is one joined component and is identical for the Cayenne S and Cayenne Turbo.

## Technical Data, Valve Drive

Intake valve diameter	.....38.3mm
Intake valve lift, large	.....11.0mm
Intake valve lift, small	.....3.6mm
Exhaust valve diameter	.....33.0mm
Exhaust valve lift, cyl. 3, 4, 5, 7	.....9.2mm
Exhaust valve lift, cyl. 1, 2, 6, 8	.....8.0mm
Intake valve angle	.....13.5°
Exhaust valve angle	.....15.4°
Fuel injector installation angle	.....29.0°
Camshaft bearing diameter	.....28.0mm

To ensure efficient gas exchange and valve lift control, the camshaft mount is 9 mm higher on the intake side compared to the outlet side. This arrangement meant that it was possible to optimize the intake port. The cooling system was designed in such a way that high temperature parts are optimally cooled. The cylinder head is made of AlSi7Mg.



Cylinder head water jacket.

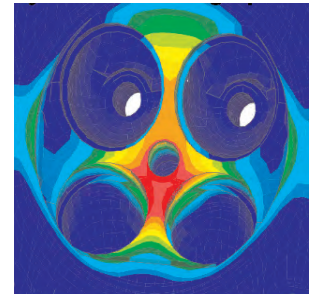

Combustion chamber stress area.

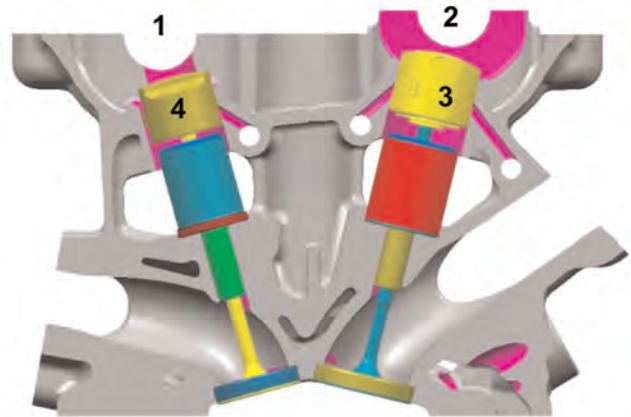

1 - Exhaust side  
2 - Intake side  
3 - Operating plunger  
4 - Outlet valve tappet



# Engine – Cayenne S/T – 2nd Generation

## Vane Controller

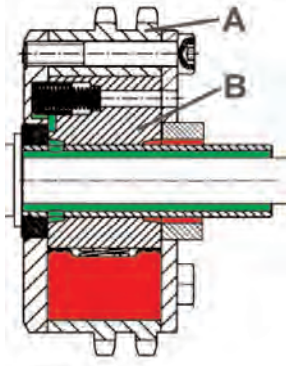

A - Stator

B - Rotor

The vane controller consists essentially of the stator (**-A-**), which is installed on the crankshaft via the sprocket, the rotor (**-B-**), which is installed on the camshaft, the inserted vanes and two lids. The sprocket is mounted to the outer diameter of the stator. It is interlocked with the crankshaft via the chain drive. The rotor is screwed securely to the camshaft. Rotation is possible between the rotor and stator (inner mounting of the controller). The rotation is limited by the vanes inserted in the rotor and by the stops on the stator. The vanes also divide the recesses on the stator into two separate chambers.

These chambers can be filled with oil via oil bores and oil passages in the rotor. To guarantee secure sealing, small springs are installed between the vanes and rotor. The chambers are each sealed off at the sides with a lid fixed to the sprocket. The controller is locked at a stop (retarded). To do this, a spring-loaded pin in the retarding device of the controller moves into a bore in the lid. An interlocked connection between the stator and the rotor is created for the engine's starting process. This locking prevents noises during the period before oil pressure is produced.

### Function

Two chambers, which act in different directions of flow, are contained in the controller. Filling of one chamber turns the rotor with respect to the stator. The rotor and the camshaft can be turned back into the original position by filling the other chamber. The oil of the non-pressurized chamber flows back into the chamber via the solenoid hydraulic valve.

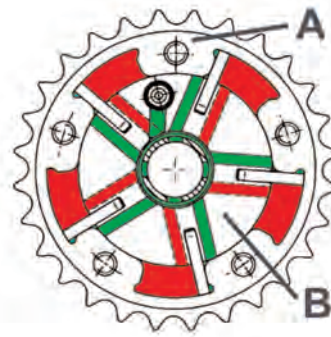

A - Stator

B - Rotor

If the oil supply and the oil return are interrupted at the solenoid hydraulic valve (center position of the valve) during the filling of a chamber, the controller remains at the position just assumed. The chambers lose oil through leakage so that the controller leaves its position. The solenoid hydraulic valve is controlled correspondingly by the control unit, and the controller returns to the desired position.

### Solenoid Hydraulic Valve

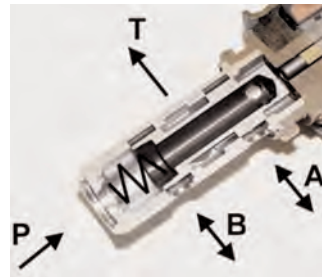

T - Solenoid hydraulic valve

P - Main oil pressure

A - Control pressure

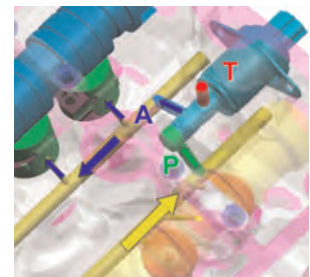

The solenoid hydraulic valve is designed as a 4-way proportional valve, which connects one of the two control lines (**-A/B-**) to the oil pressure supply line (**-P-**) depending on the control unit specification and opens the other line so that the oil can flow into the crank chamber (**-T-line-**).



# Engine – Cayenne S/T – 2nd Generation

If the **-A-** line is pressurized with oil, the controller will change direction to advance the valve timing. If the **-B-** line is pressurized with oil, the controller will change direction to retard the valve timing. Both control lines are closed in the center position. The camshaft is held in the desired position. In addition, any intermediate position between the three switch positions described above can be set via the control unit.

Therefore, it is possible not only to move the adjustment position very quickly but also to move it very slowly in the case of slight deviations of the valve from the central position. In this way, the solenoid hydraulic valve defines the adjustment direction and speed of the controller.

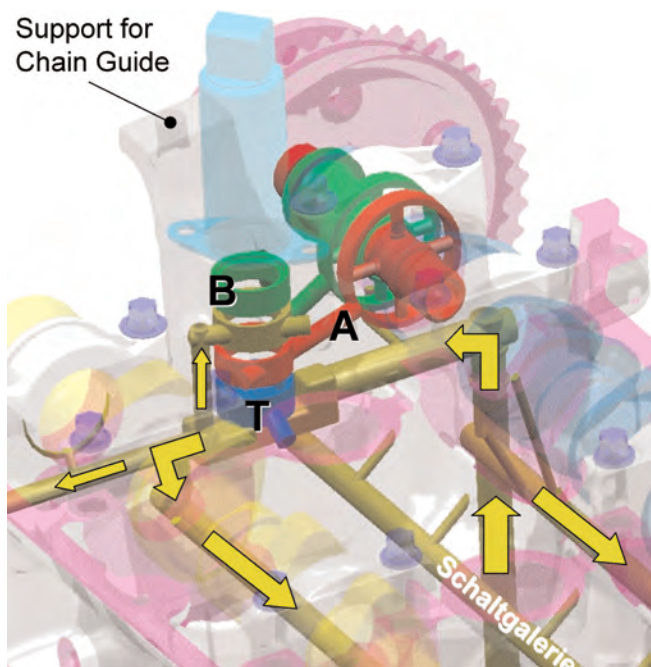

- Oil supply for cam phaser camshaft bearings and timing chain tensioner integrated in one bearing support.
- Screw connection of bearing support together with cam cap bolts.
- Oil Supply for first camshaft bearing (intake side) integrated in A-B oil supply for cam phaser (bleed > T).
- Advantage: no separate oil supply housing (V8 - 4.5) and no square section sealing rings necessary.

## Tappet Evolution



Cayenne V8 engines use a “Ultra Leichtbau” lightweight 3CF bucket tappet.

### Advantages are:

- Reduced mass
- Increased rigidity

## Cylinder Head Design

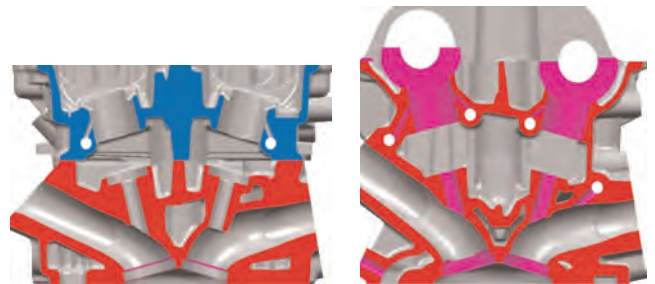

Previous Cylinder Head

2nd Generation Cylinder Head

Additional weight savings were gained from the second generation V8 engine cylinder head design. On the left is the previous V8 4.5 liter cylinder head – fully machined, total weight including camshaft housing and bolts was 41 lbs (18.6 kg). On the right is the new second generation 4.8 liter head – fully machined, total weight including valve cover and DFI is 28 lbs (12.6 kg).

### Notes:

---

---

---

---

---

---

---

---

---

---

# Engine – Cayenne S/T – 2nd Generation

## Scavenging Concept

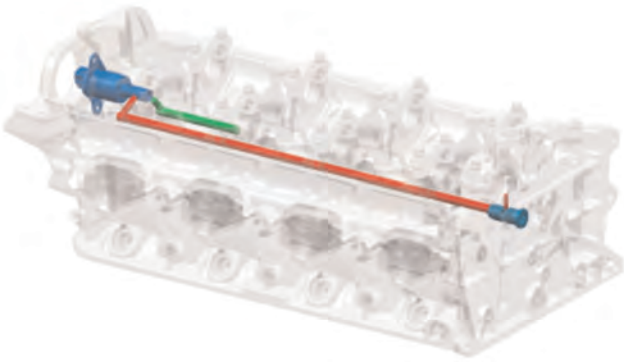

A scavenging restrictor is installed on the end of the control pressure line to keep the switching time to a minimum during valve lift control. This scavenging restrictor is used to bleed the line and reduce switching time.

## Check Valve

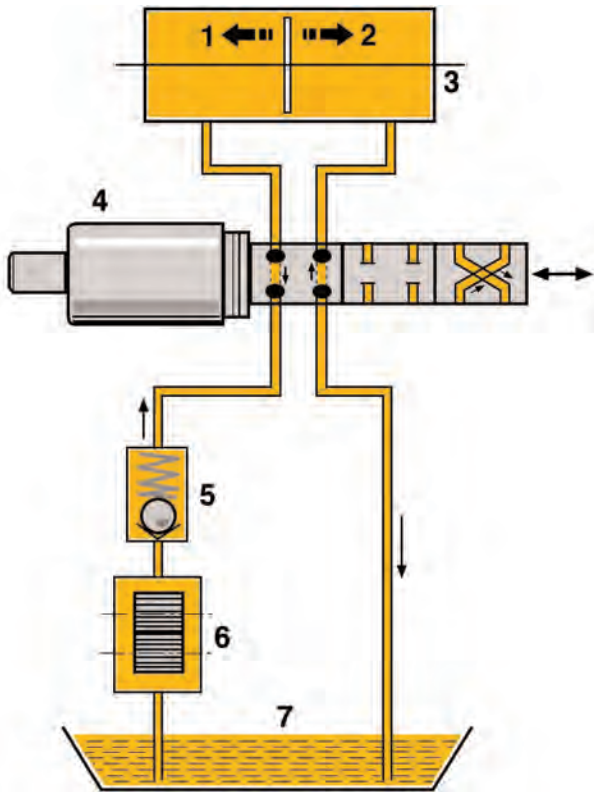

- 1 - Adjustment direction retarded
- 2 - Adjustment direction advanced
- 3 - Camshaft controller
- 4 - Solenoid hydraulic valve
- 5 - Check valve
- 6 - Oil pump
- 7 - Oil pan

The camshaft requires a high drive torque at times due to the valve actuation, but the camshaft continues rotating unaided at other times (alternating torques). If a check valve is inserted into the P-line and the solenoid hydraulic valve is energized, for example (adjustment in direction of advanced valve timing), the controller automatically intakes oil via the feed line, the solenoid hydraulic valve and the check valve for an advancing camshaft. If the camshaft then tries to lag due to the high drive torque, the check valve closes and the oil cannot escape. The camshaft is driven by the oil cushion of the sprocket during this time, as with a freewheel. The advancing and lagging phases of the camshafts repeat so that the camshaft automatically shifts to advanced valve timing in stages.

As the principle described above only functions with well sealed adjustment control systems and low-friction valve drives, oil pressure is required. To ensure that an extremely large oil pump is not required, the principle described above is taken advantage of when the engine is hot and at a low oil pressure through the use of the check valve. The check valve serves to increase the adjustment speed at low oil pressures.

## Valves, Valve Springs

The intake and exhaust valves on the Cayenne S and Cayenne Turbo have a shaft diameter of 6 mm. The intake and exhaust valves are bi-metallic, i.e. the materials used for the valve plate and the lower part of the valve stem are different to those used for the upper part of the valve stem. In addition, the exhaust valves on the Cayenne Turbo are filled with sodium.

The intake valve springs on the Cayenne S and Cayenne Turbo are identical. They are designed as a conical double valve spring set. This gives a very compact design. The exhaust valve springs on the Cayenne S are conical single valve springs. The Cayenne Turbo features cylindrical double-valve spring sets to ensure that the exhaust valves close, even at higher pressures in the exhaust system.

## Vacuum Pump

Increased engine dethrottling means that the vacuum supply is no longer sufficient for unfavorable underlying conditions, e.g. low external air pressure at high altitudes and highly dynamic driving. A mechanical single-vane pump driven by the camshaft is used for this reason.

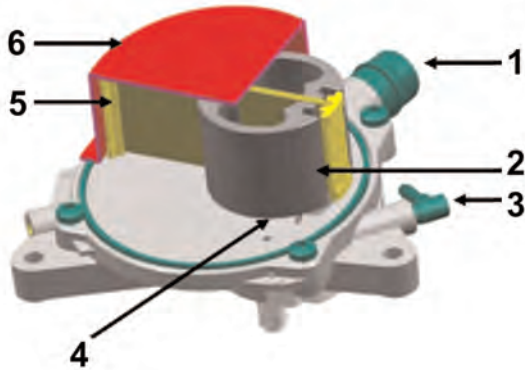

The pump delivery rate is 260cm<sup>3</sup>/revolution.

- 1 - Intake opening
- 2 - Rotor
- 3 - Secondary load connection
- 4 - Outlet valve in crank chamber
- 5 - Vane with guide shoes
- 6 - Housing

## Notes:

---

---

---

---

---

---

---

---

---

---

---

---

---

---

---

---

---

---

---

---

---

---

---

## Timing Drive Mechanism

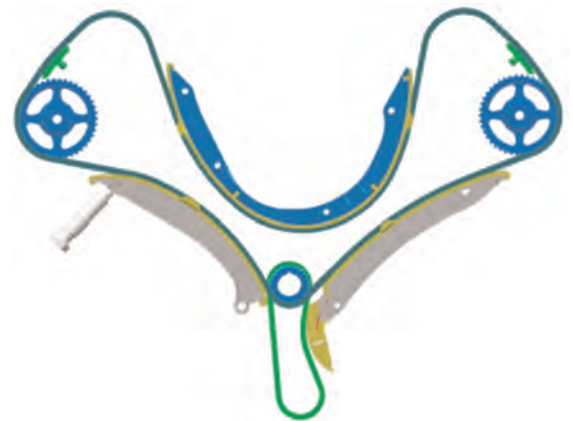
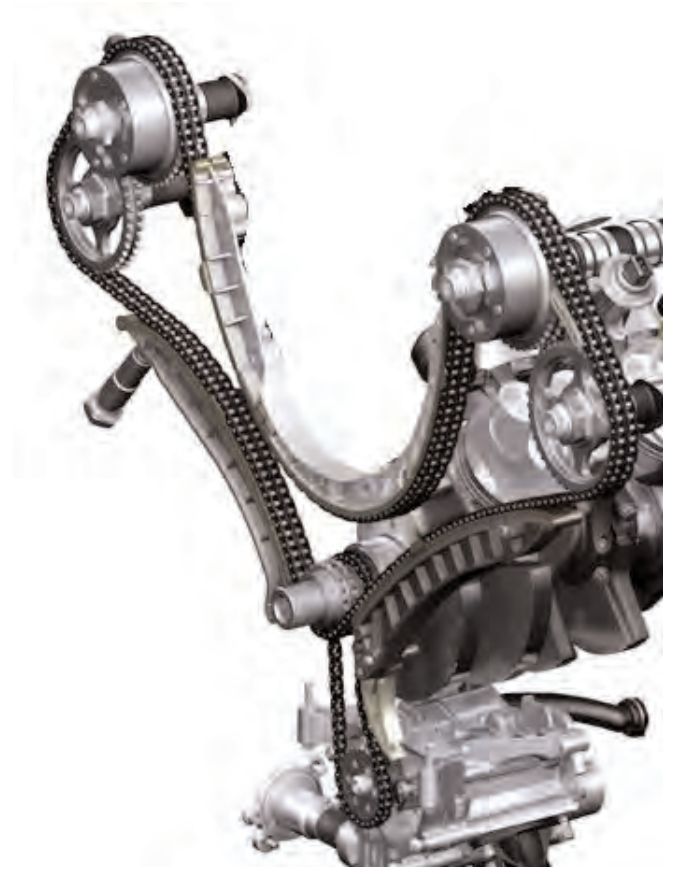

The chain is guided by two specially coated guide rails. The lower guide rail on cylinder row 1 to 4 is also designed as a tensioning rail. The hydraulic chain tensioner is connected to the engine oil circuit and is totally maintenance free.



## Lubricating Oil System

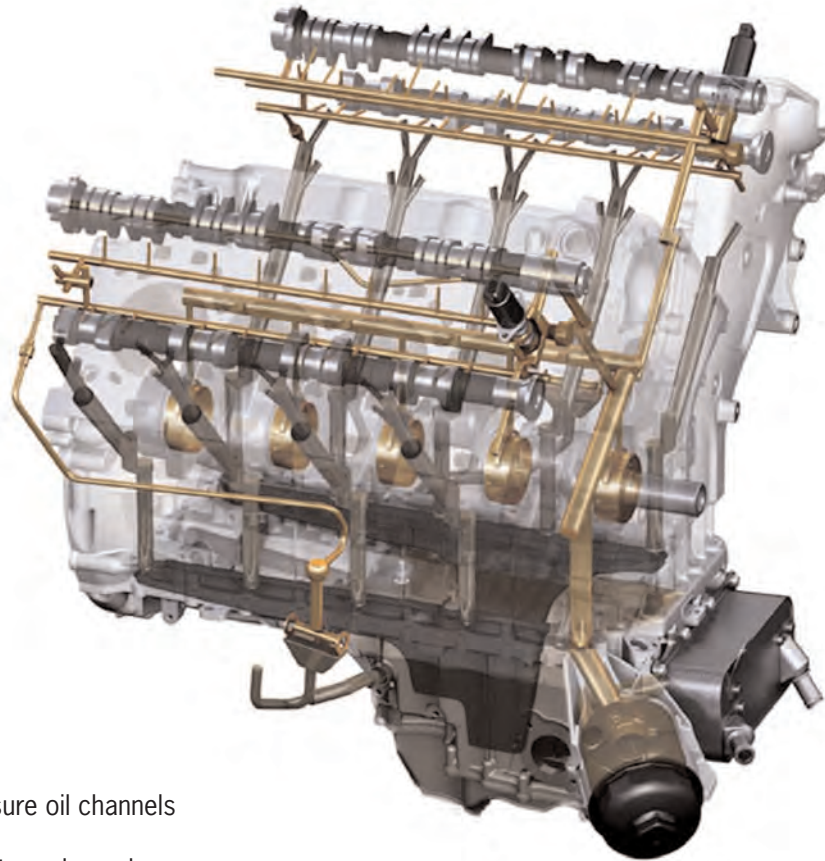

- A** - Pressure oil channels
- B** - Oil return channels

To ensure a reliable oil supply in all driving situations, the V8 engines in the Cayenne S and Cayenne Turbo have an integrated dry-sump lubrication system.



The oil pan is designed in two parts and has an upper and lower part. The oil-water heat exchanger and the oil filter are fitted directly on the upper part of the oil pan. To ensure a lightweight design, the windage tray, the oil return collection tank and the suction pipe are all together in a plastic housing fitted in the oil pan.

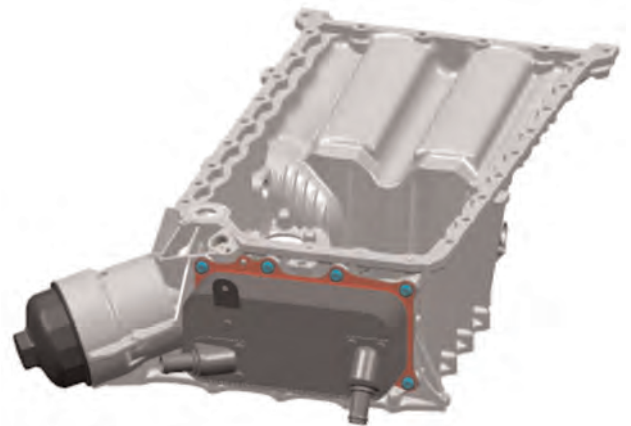

The oil pan wall is very thin so as to keep the weight as low as possible.

# Engine – Cayenne S/T – 2nd Generation

## Oil Pump

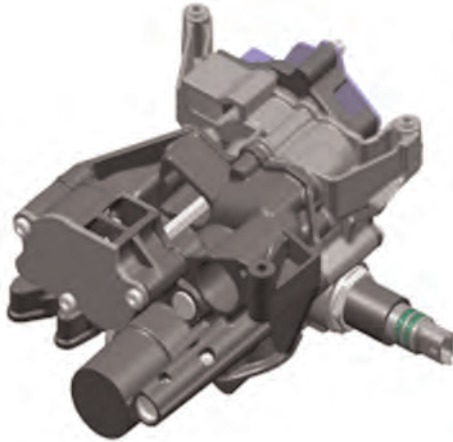

The integration of VarioCam Plus, the mechanical vacuum pump and the fact that the lower part of the crankcase is fully aluminum means that oil throughput on the Cayenne S and Cayenne Turbo is very high. A relatively large and efficient pump must be used to guarantee the required oil supply. However, a lot of energy is required to drive such a pump and this energy requirement in turn increases fuel consumption. To counteract this, a variable oil pump is used for the first time in the Cayenne S and Cayenne Turbo.

## Function

Depending on the input values for engine rpm, engine load, engine oil temperature and the expected change in engine rpm, a specific control valve position (-4-) is defined using a map in the DME control unit. The control valve position regulates the oil pressure for the spring piston on the gear wheel, which can move in axial direction. The oil pressure on the control piston is not regulated on the other side. The control valve is open fully in the non-energized state and as a result, the oil pressure is the same on both sides, which means that the gear wheel will not move.

In other words: the pressure difference between the spring piston and the control piston can be used to control every position. When the gear wheel moves, the teeth are still only partially engaged and as a result, performance and friction as well as energy requirements are reduced.

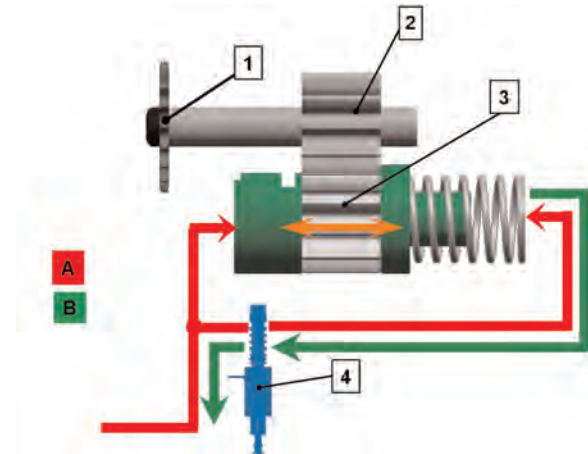

- 1 - Oil pump chain drive gear
- 2 - Oil pump driven gear
- 3 - Movable oil pump gear
- 4 - Oil pump control valve (lowers pressure on spring end of control piston)

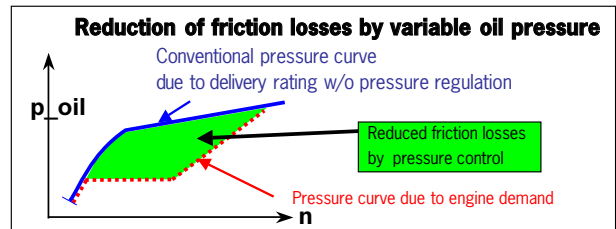
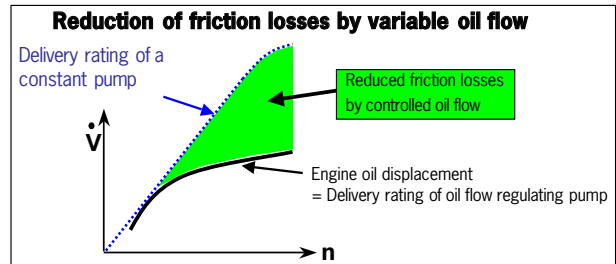

## Notes:

---

---

---

---

---

---

---

---

---

---

---

---



## Engine – Cayenne S/T – 2nd Generation

### Positive Crankcase Ventilation – Naturally Aspirated Engine

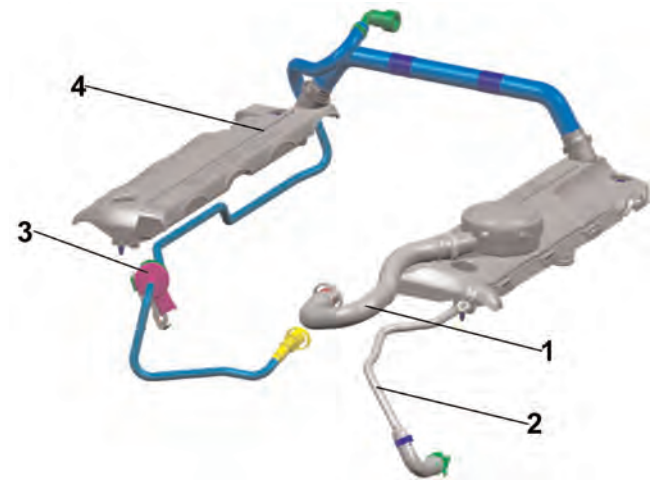

- 1 - Return connection for blow-by gases
- 2 - Return line
- 3 - Tank vent
- 4 - Positive crankcase ventilation

For this purpose, fresh air is removed between the charge air cooler and throttle valve and is delivered to the crank chamber via a line. The pressure that exists at any time between the removal position and the crankcase causes a steady flow of fresh air through the crankcase. To ensure enough vacuum in the crankcase in all operating states, the vacuum in the intake manifold is used in the part-load ranges. A pressure regulating valve regulates this vacuum until the required value is reached. The vacuum from the compressor is used in the boost range (no vacuum present).

### Positive Crankcase Ventilation - Turbo Engine

The positive crankcase ventilation system in the Cayenne Turbo can reduce the amount of fuel that goes into the engine oil during combustion. The aeration and ventilation system (Positive Crankcase Ventilation-PCV) ventilates the crankcase with a steady stream of fresh air, which accelerates the evaporation of fuel that is carried in.

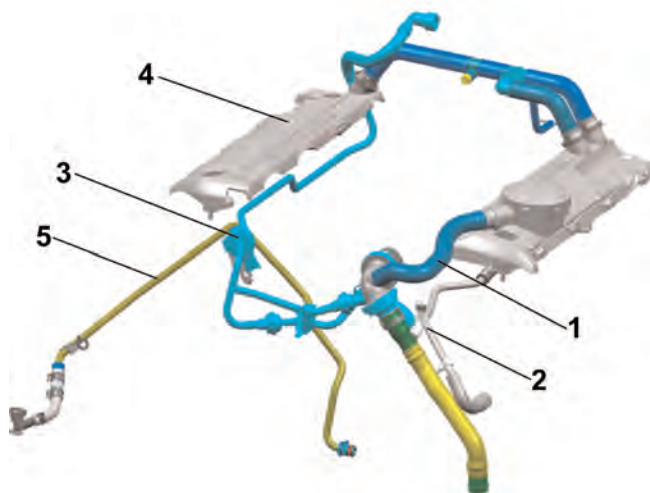

- 1 - Return connection for blow-by gases
- 2 - Return line
- 3 - Tank vent
- 4 - Positive crankcase ventilation
- 5 - PCV connection



Cayenne S Cooling System

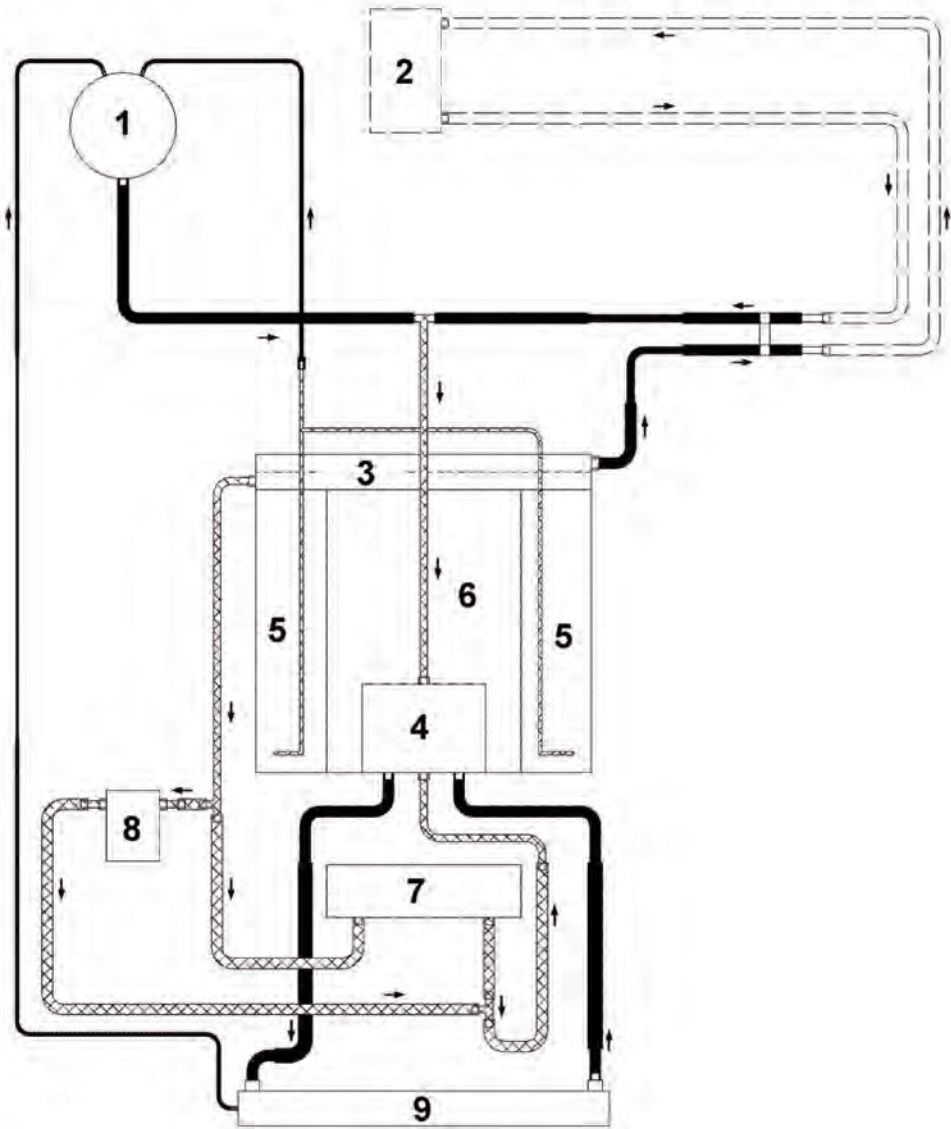

- 1 - Coolant reservoir
- 2 - Heat exchanger
- 3 - Coolant collection pipe
- 4 - Coolant pump/thermostat housing
- 5 - Cylinder head
- 6 - Crankcase
- 7 - Oil-water heat exchanger
- 8 - Generator
- 9 - Radiator

# Engine – Cayenne S/T – 2nd Generation

## Cayenne Turbo Cooling System

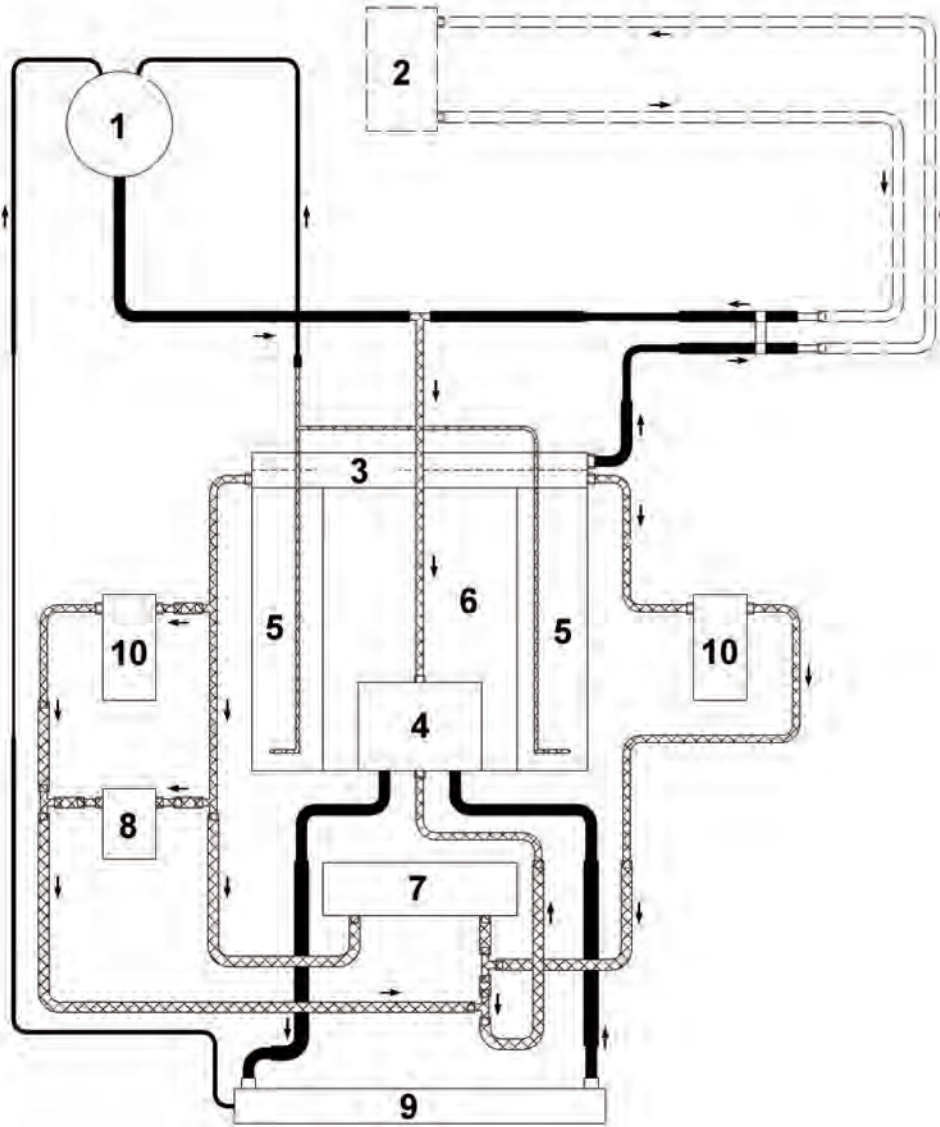

- 1 - Coolant reservoir
- 2 - Heat exchanger
- 3 - Coolant collection pipe
- 4 - Coolant pump/thermostat housing
- 5 - Cylinder head
- 6 - Crankcase
- 7 - Oil-water heat exchanger
- 8 - Generator
- 9 - Radiator
- 10 - Turbocharger



<b>Subject</b>	<b>Page</b>
General .....	3
Cayenne Engine Data .....	3
Crankcase .....	3
Pistons .....	4
Connecting Rods .....	4
Belt Drive .....	5
V-Angle .....	6
Cylinder Head .....	6
Camshaft Adjustment .....	6
Exhaust Gas Recirculation .....	8
Positive Crankcase Ventilation .....	9
Cyclone Oil Separator .....	10
Oil Lubrication System .....	11
Cooling System .....	13



# Engine – Cayenne (V6) – 2nd Generation

## 1 - Engine M 55.01



### General

The Cayenne engine is designed as a 6-cylinder, direct fuel injection V engine. The 3.6 liter V6 cylinder engine offers a wide rpm range improved power output and torque combined with low fuel consumption and emission values. Being a long-stroke engine, the V6 generates high torque even at low rpms.

### Engine Data – Second Generation V6

Engine type	.....M55.01
No. of cylinders	.....6
Bore	.....89 mm
Stroke	.....96.4 mm
Displacement	.....3.6 Liter
V-angle	.....10.6°
Compression ratio	.....12.0
Max. output	.....290 HP (213 kW)
At engine speed	.....6200 rpm
Max. torque	.....285 ftlb. (385 Nm)
At engine speed	.....3000 rpm
Governed speed	.....6700 rpm
Engine weight (manual transmission)	.. 417 lbs (189 kg)
Engine weight (Tiptronic)	.....390 lbs (177 kg)
Firing order	.....1-5-3-6-2-4

### Crankcase



The crankcase with the cylinders is made of grey cast iron with lamellar graphite in weight optimized design. The cylinders are arranged in a staggered configuration in the 10.6° V-angle. The cylinder number 1 is located on the passenger side.

# Engine – Cayenne (V6) – 2nd Generation

## Crankshaft

The drop-forged crankshaft runs on seven bearings. Main bearing 4 is designed as a thrust bearing. Axial play is determined by two thrust plates, which are inserted into the bearing supports. The main bearings are two-component bearings and have a diameter of 60 mm.

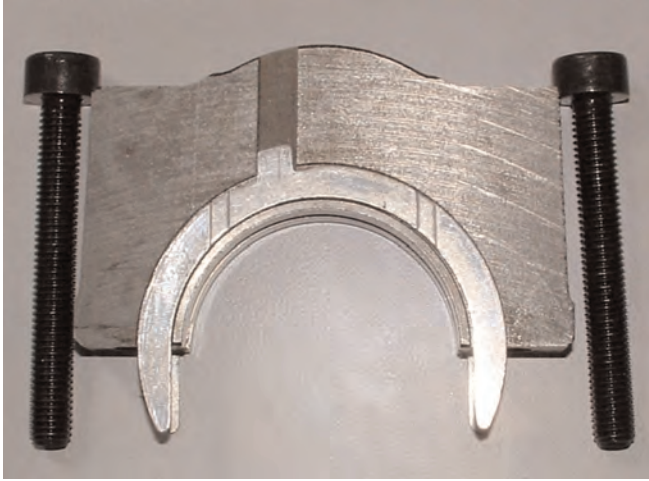

Located on the crankshaft are the pulse-generating wheel for the speed and reference mark transmitter **-A-** and the drive sprocket for the intermediate shaft **-B-**.



### Notes:

---

---

---

---

---

---

---

---

---

---

## Pistons

The pistons are designed as recessed pistons made of aluminum alloy. They have a graphite friction coating at the sides to improve friction performance of the piston. The pistons are different for cylinder bank 1 and cylinder bank 2. The valve recesses and combustion chamber troughs are arranged differently. The position and shape of the piston recess allows the injected fuel to be whirled around and mixed with the air that is drawn in.



- 1 - Friction coating
- 2 - Piston recess

## Connecting Rods

The connecting rods are cut rather than cracked. The conrod eye is trapezoid. The conrod bearings are two-component bearings with a diameter of 54 mm and are molybdenum coated, which ensures good friction characteristics and a high load capacity.

## Belt Drive

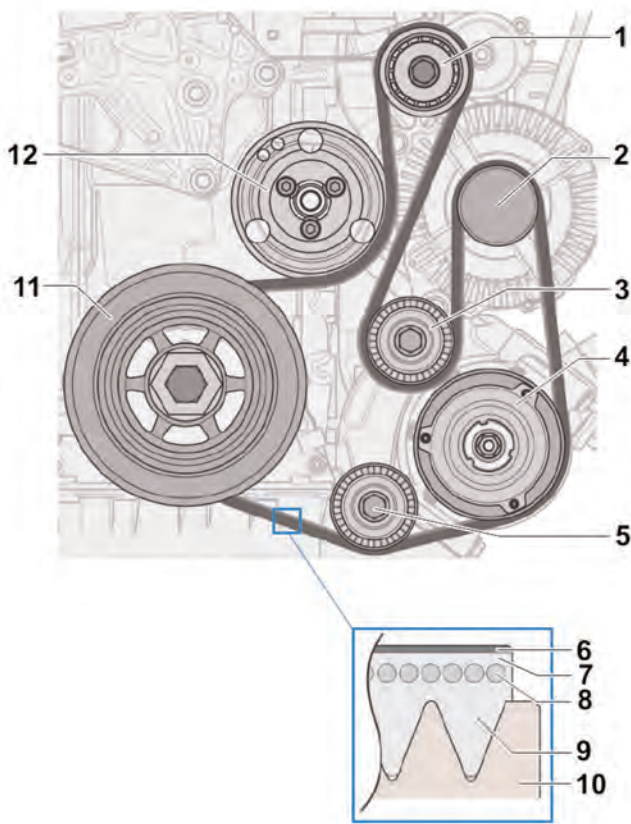

- 1 - Tensioning roller
- 2 - Generator drive
- 3 - Deflection roller
- 4 - Air conditioning compressor drive
- 5 - Deflection roller
- 6 - Outer fabric
- 7 - Covering plate
- 8 - Polyester cord
- 9 - Substructure
- 10 - Poly V-belt pulley
- 11 - Crankshaft poly V-belt pulley
- 12 - Coolant pump drive

The poly V-belt is a single sided poly V-belt. The belt is driven by the crankshaft via the poly V-belt pulley with vibration damper. The air conditioning compressor, generator and coolant pump run in the belt drive. A belt tensioner ensures that the poly V-belt is always tensioned correctly.

## Chain Drive

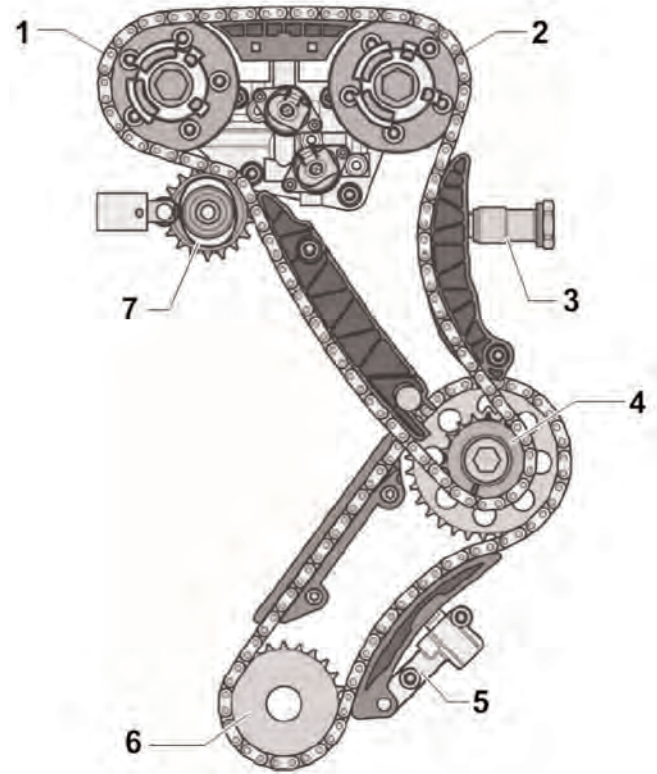

- 1 - Inlet camshaft drive
- 2 - Outlet camshaft drive
- 3 - Hydraulic chain tensioner
- 4 - Oil pump drive
- 5 - Hydraulic chain tensioner
- 6 - Crankshaft gear
- 7 - Fuel high pressure pump drive

The chain drive is on the power output side of the engine. It consists of the primary roller-type chain and the camshaft roller-type chain. The primary roller-type chain is driven by the crankshaft. It drives the camshaft roller-type chain and the oil pump via a sprocket. The camshaft roller-type chain drives the two camshafts and the fuel high-pressure pump. The hydraulic chain tensioner guarantees the exact tensioning of the cam drive chain.

# Engine – Cayenne (V6) – 2nd Generation

## V-Angle

The V-angle of the cylinder block is 10.6° (previously 15°). This small V-angle ensures the required cylinder wall strengths without increasing the installation dimensions of the engine.

## Articulation

The small V-angle causes the longitudinal axis of the cylinder to move outward with respect to the lower crankshaft. The distance between the longitudinal axis of the cylinder and the crankshaft center axis is the articulation. Accordingly, the small V-angle increases the articulation (in this case: 22 mm).

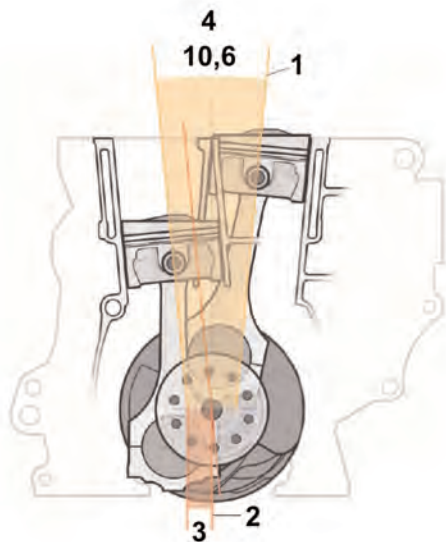

1 - Longitudinal axis of cylinder

2 - Crankshaft center axis

3 - Articulation

4 - V-angle

## Cylinder Head

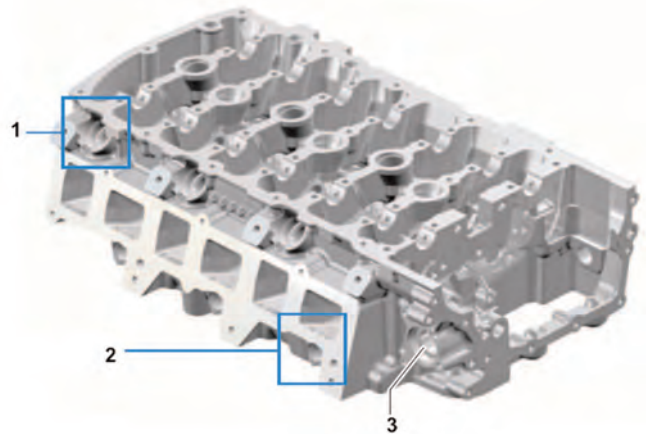

1 - Installation position of fuel injectors 1, 3, 5

2 - Installation position of fuel injectors 2, 4, 6

3 - Installation position of fuel high pressure pump

The one piece cylinder head is made of an aluminum silicon copper alloy. The cylinder head is used both for mounting the chain drive and for connecting the fuel high pressure pump. The fuel injectors for both cylinder banks are on the intake side of the cylinder head.

The bores for the fuel injectors for cylinders 1, 3 and 5 are above the intake manifold flange. The fuel injectors for cylinders 2, 4 and 6 are inserted below the intake manifold flange. This arrangement allows the fuel injectors for cylinders 1, 3 and 5 to run through the intake port on the cylinder head.

## Camshaft Adjustment

The intake and exhaust camshafts are adjusted by way of a vane adjuster. The DME control unit determines the current position of the camshaft in relation to the crankshaft (actual angle) on the basis of the speed sensor signal and the Hall sender signal. The position controller in the control unit receives the desired nominal angle via the programmed map values (speed, load, engine temperature). A regulator in the DME control unit activates a solenoid hydraulic valve according to the desired adjustment when there is a difference between the nominal angle and actual angle. The adjustment angle is 52° in relation to the crankshaft on the intake side and 22° in relation to the crankshaft on the exhaust side.





## Engine – Cayenne (V6) – 2nd Generation

The DME control unit actuates electromagnetic valves 4 and 5 to adjust the camshafts. The valves subsequently open oil passages in the timing chain housing. The engine oil then flows via the timing chain housing and the camshaft into the vane adjuster. The vane adjusters turn, adjusting the camshafts in accordance with the instructions from the DME control unit.

### Exhaust Gas Recirculation

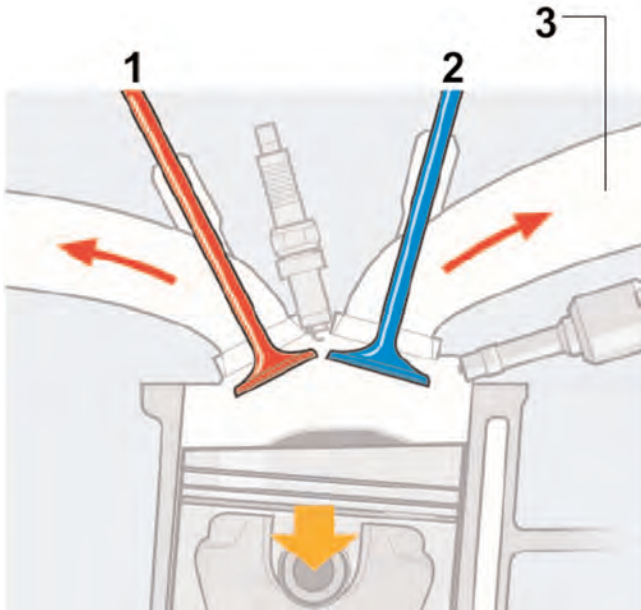

- 1 - Exhaust valve
- 2 - Intake valve
- 3 - Intake manifold vacuum

Internal exhaust gas recirculation counteracts the formation of nitrogen oxides NO<sub>x</sub>. Just like external exhaust gas recirculation, the formation of NO<sub>x</sub> is based on the fact that the combustion temperature is reduced through the introduction of combustion exhaust gases. The combustion gases in the fresh air/fuel mixture cause a slight lack of oxygen, whereby the combustion does not become as hot as it would if there was surplus oxygen. Nitrogen oxides are only formed in a greater concentration at a relatively high temperature. The reduced combustion temperature in the engine and the lack of oxygen prevent the formation of NO<sub>x</sub>.

### Function

Both the intake and exhaust valves are open during the exhaust stroke. The high intake manifold vacuum causes some of the combustion gases from the combustion chamber to be sucked back into the intake port and then flushed back into the combustion chamber for the next combustion with the next intake stroke.

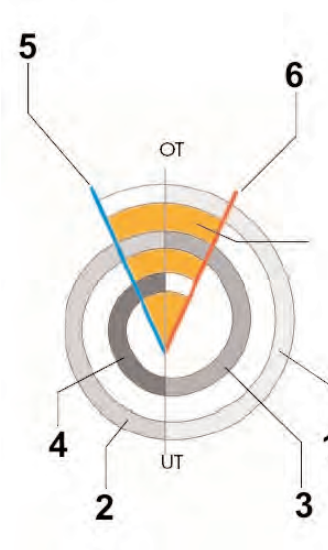

- 1 - Stroke 1
- 2 - Stroke 2
- 3 - Stroke 3
- 4 - Stroke 4
- 5 - Intake valve opens
- 6 - Exhaust valve closes

### This has the following advantages:

- Reduced consumption due to reduced gas exchange work.
- Increased part-load range with exhaust gas recirculation.
- Smoother running.
- Exhaust gas recirculation is possible even when the engine is cold.



## Engine – Cayenne (V6) – 2nd Generation

### Cyclone Oil Separator

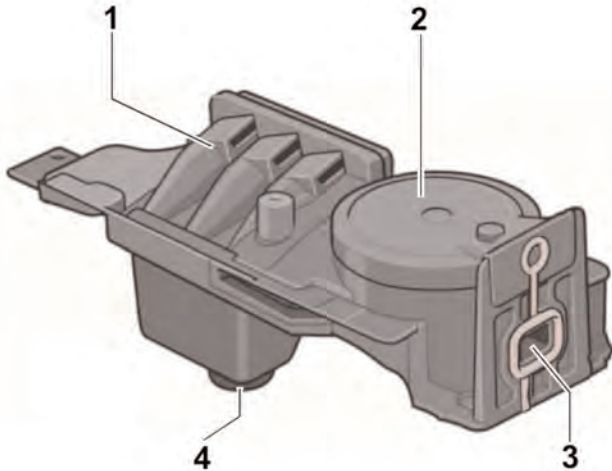

- 1 - Cyclone oil separator
- 2 - Pressure regulating valve
- 3 - To intake manifold
- 4 - Oil discharge opening

The cyclone oil separator is in the cylinder head cover. Its main function is to separate oil from the blow-by gases in the crankcase and return it to the oil circuit. A pressure regulating valve limits the intake manifold vacuum from approx. 700 mbar to approx. 40 mbar. This prevents the entire intake manifold vacuum and the internal crankcase pressure from affecting positive crankcase ventilation, thereby drawing in engine oil or damaging seals.

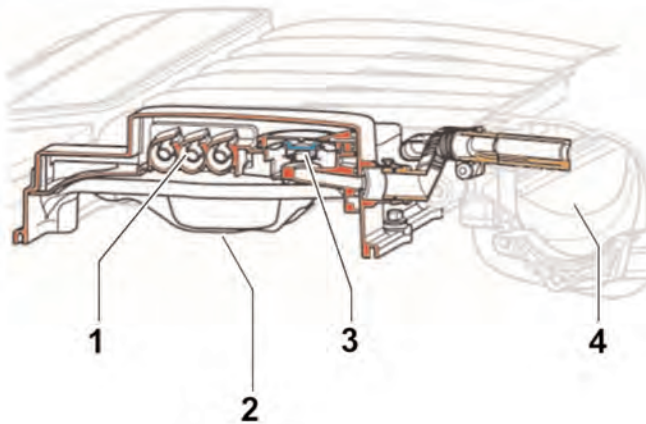

- 1 - Cyclone oil separator
- 2 - Oil-discharge opening
- 3 - Vacuum valve
- 4 - Intake manifold

### Function

The cyclone oil separator separates the oil from the oil vapor that is drawn in. It works according to the principle of centrifugal separation. The cyclone design of the oil separator means that the oil vapors are moved in a rotating movement. The centrifugal force that is created flings the oil onto the partition wall, where it combines to form larger drops. While the separated oil drips into the cylinder head, the gas particles are fed into the intake manifold through a flexible pipe.

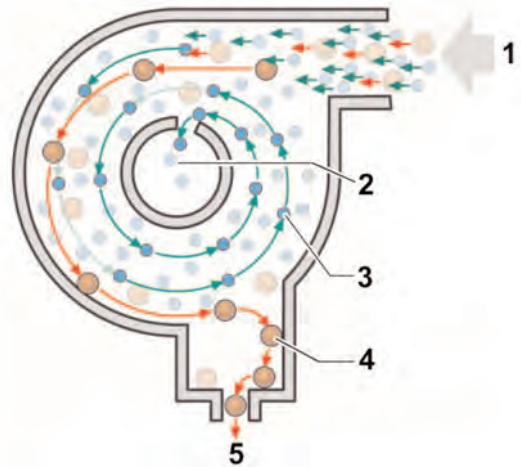

- 1 - Intake
- 2 - Gas feed to intake manifold
- 3 - Gas particles
- 4 - Oil drops
- 5 - Oil-discharge opening in crankcase

### Positive Crankcase Ventilation Heating

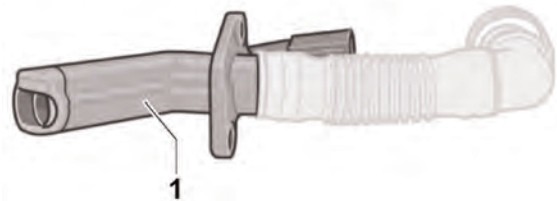

The heating element -1- is inserted in the flexible pipe connecting the cyclone oil separator to the intake manifold and prevents the incoming blow-by gases from freezing when the intake air is very cold.





Cooling System

- 1 - Reservoir
- 2 - Heat exchanger
- 3 - Coolant pump
- 4 - ATF/water heat exchanger
- 5 - Coolant thermostat
- 6 - Oil/water heat exchanger
- 7 - Check valve
- 8 - Electric additional coolant pump
- 9 - Check valve
- 10 - Additional radiator
- 11 - Vehicle radiator

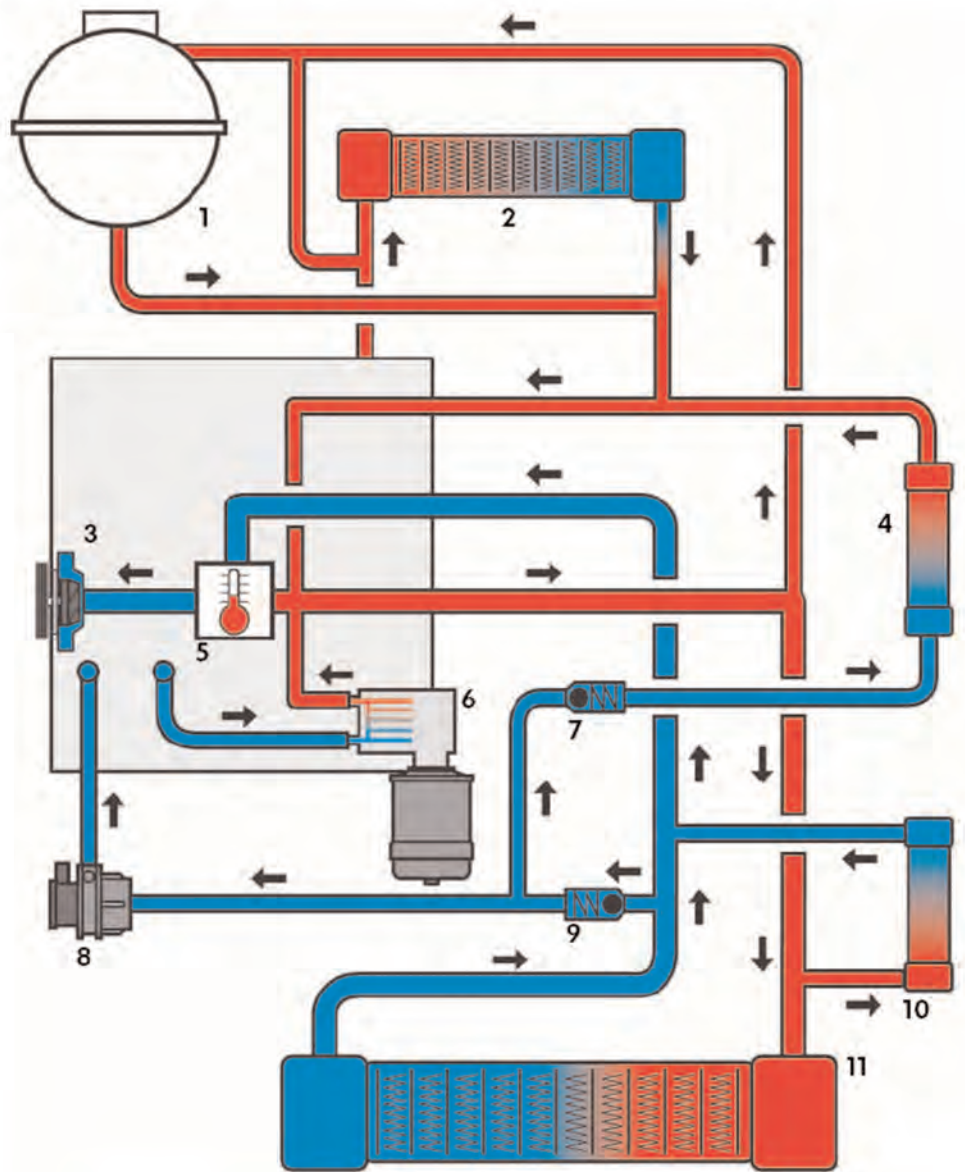

Coolant is circulated by the mechanical coolant pump. The pump is driven by the poly V-belt. The circuit is controlled by the thermostat. The check valves are integrated into the circuit in such a way as to prevent coolant flowback.

The amount of coolant depends on the vehicle equipment and is generally between 14 qts (13.2 liters) and 18.6 qts (17.6 liters).

Notes:

---



---



---



---



---



---



---



---



---



---





**Temperature Conversion**



**Metric Conversion Formulas**

INCH . . . . .	X	25.4	=	MM
MM . . . . .	X	.0394	=	INCH
MILE . . . . .	X	1.609	=	KILOMETER (KM)
KM (KILOMETER) . . . . .	X	.621	=	MILE
OUNCE . . . . .	X	28.35	=	GRAM
GRAM . . . . .	X	.0352	=	OUNCE
POUND (lb) . . . . .	X	.454	=	KILOGRAM (kg)
kg (KILOGRAM) . . . . .	X	2.2046	=	lb (POUND)
CUBIC INCH . . . . .	X	16.387	=	CUBIC CENTIMETER (cc)
CC (CUBIC CENTIMETER) . . . . .	X	.061	=	CUBIC INCH
LITERS . . . . .	X	.0353	=	CUBIC FEET (cu.ft.)
CUBIC FEET (cu.ft.) . . . . .	X	28.317	=	LITERS
CUBIC METERS . . . . .	X	35.315	=	CUBIC FEET (cu.ft.)
FOOTPOUND(ft lb) . . . . .	X	1.3558	=	NEWTON METER (Nm)
Nm (NEWTON METER) . . . . .	X	.7376	=	ft lb (FOOT POUND)
HORSEPOWER (SAE) . . . . .	X	.746	=	KILOWATT (Kw)
HORSEPOWER (DIN) . . . . .	X	.9861	=	HORSEPOWER (SAE)
Kw (KILOWATT) . . . . .	X	1.34	=	HORSEPOWER (SAE)
HORSEPOWER (SAE) . . . . .	X	1.014	=	HORSEPOWER (DIN)
MPG (MILES PER GALLON) . . . . .	X	.4251	=	Km/l (KILOMETER PER LITER)
BAR . . . . .	X	14.5	=	POUND/SQ. INCH (PSI)
PSI (POUND SQUARE INCH) . . . . .	X	.0689	=	BAR
GALLON . . . . .	X	3.7854	=	LITER
LITER . . . . .	X	.2642	=	GALLON
FAHRENHEIT . . . . .	-	32 ÷ 1.8	=	CELSIUS
CELSIUS . . . . .	X	1.8 + 32	=	FAHRENHEIT

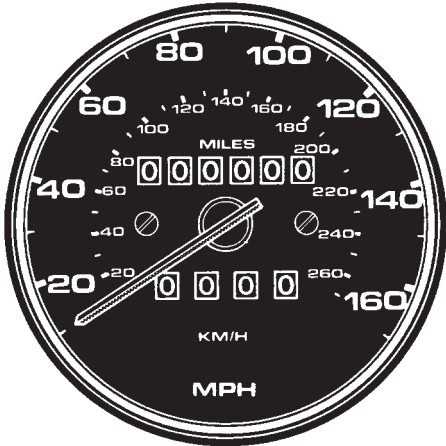





**WE SUPPORT  
VOLUNTARY TECHNICIAN  
CERTIFICATION THROUGH**

National Institute for  
**AUTOMOTIVE  
SERVICE  
EXCELLENCE**

**Part Number - PNA P10 C03**