

Removing and installing wire harness for rear spoiler

Preliminary work

Preliminary work

1. Remove rear spoiler. → 665819 *Removing and installing rear spoiler – section on "Removing"*
2. Remove auxiliary brake light. → 947019 *Removing and installing auxiliary brake light - section on "Removing"*
3. Remove engine-compartment light. → 964319 *Removing and installing bulb for engine-compartment light - section on "Removing"*

Removing wire harness for rear spoiler Disconnecting plug connection from rear lid to main wire harness

1. Open the rear lid.
2. Release the locking lug -1- for the electric plug connection -**Arrow A**- and disconnect it -**Arrow B**- .

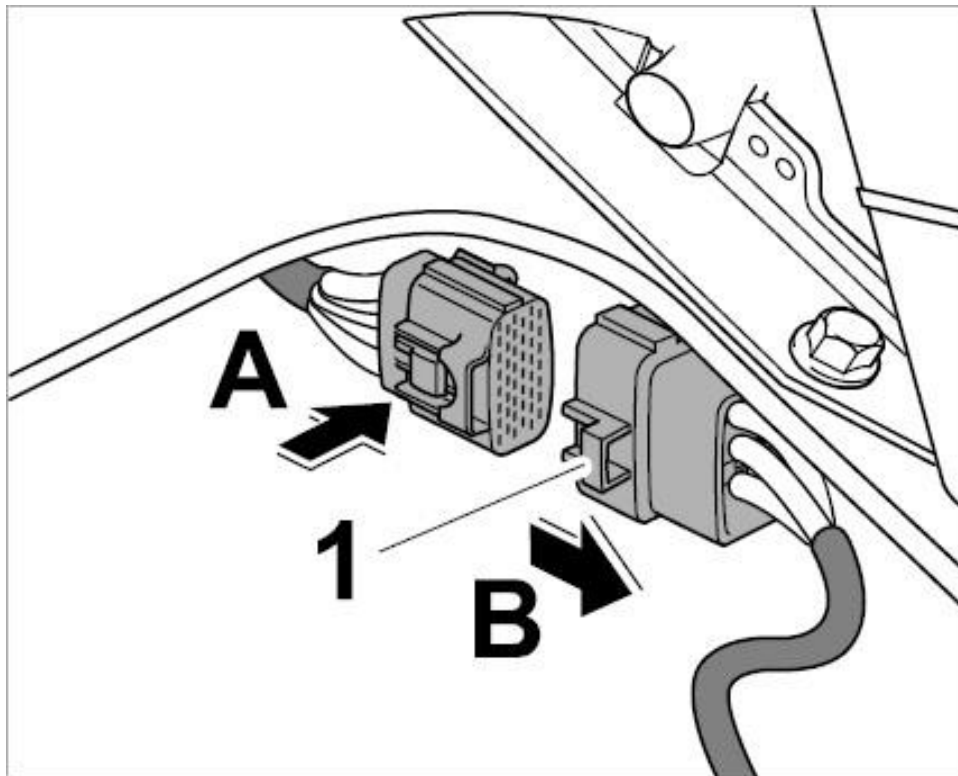

Disconnecting wire harness on rear lid

3. Open the wiring duct -**Arrow A**- and take out the line -**Arrow B**- .

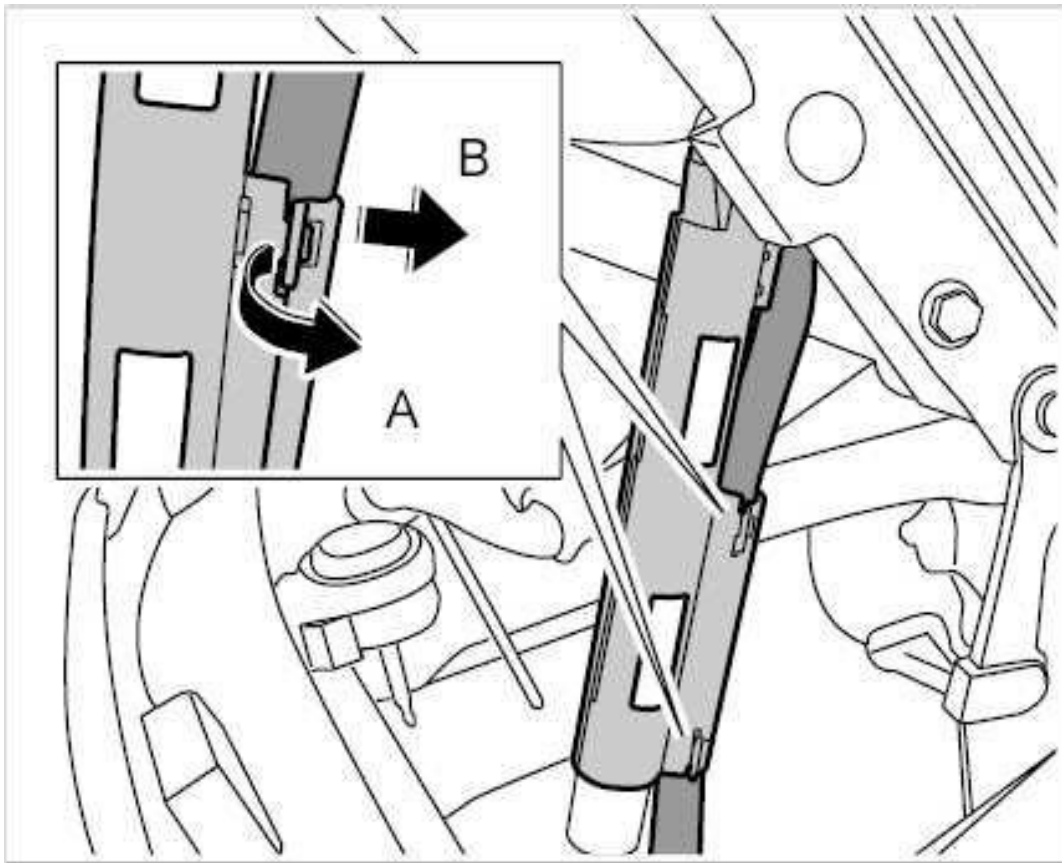

Loosening line on hinge for rear lid

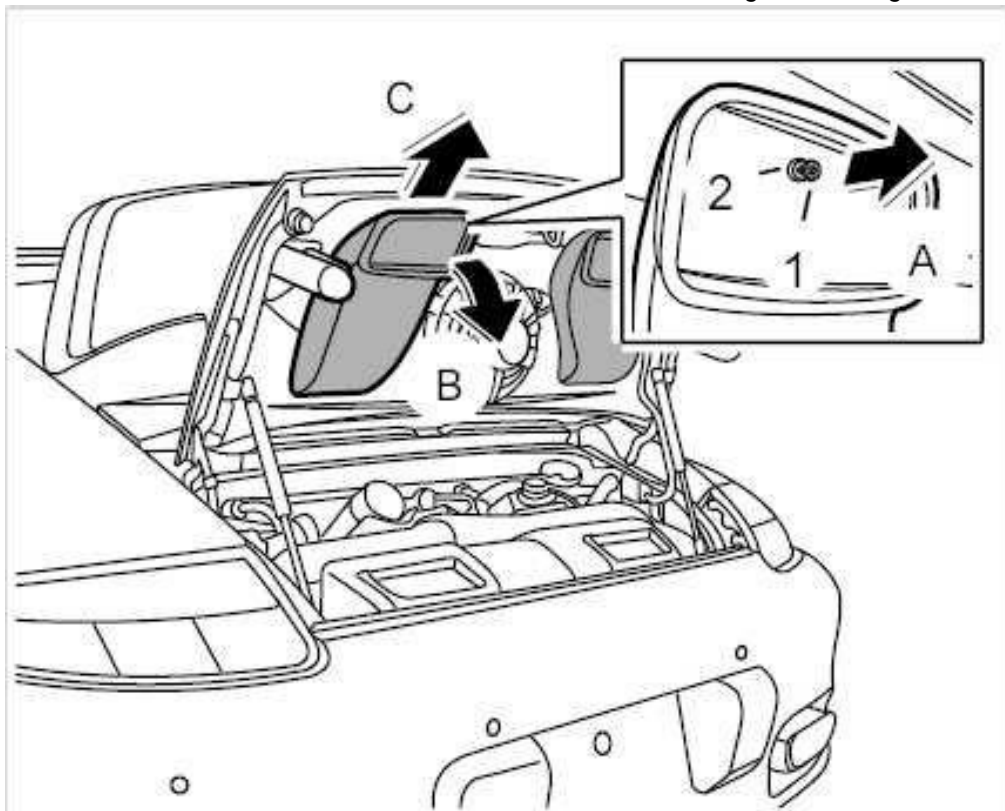

Removing air guide

1. Unscrew the screw-in pins -1- and remove the clips -2- (-Arrow A-).

Removing air guide on rear lid

2. Fold out the air guides -Arrow B- and remove them -Arrow C- .

Removing fan motor

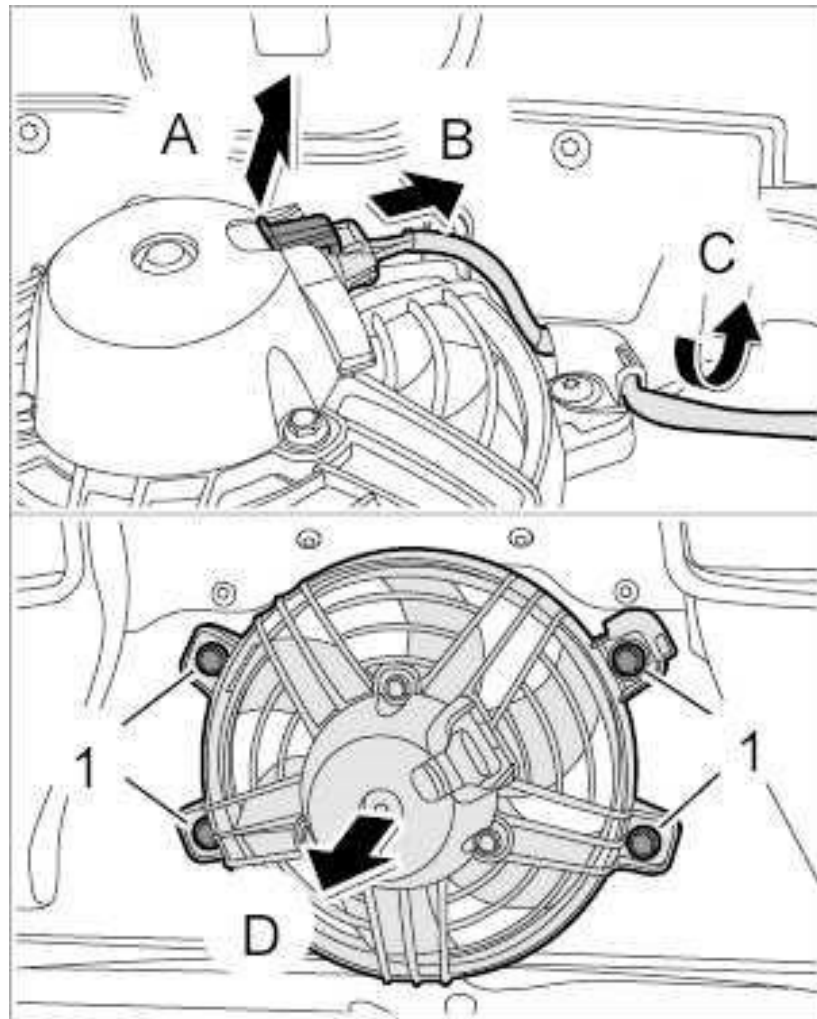

1. Disconnecting electric line

Removing fan motor from rear lid

- 1.1. Release the connector **-Arrow A-** and pull it off **-Arrow B-** .
- 1.2. Take the line out of the holder **-Arrow C-** .
2. Unscrew the fastening screws **-1-** and take out the fan motor **-Arrow D-** .

Loosening pump unit for spoiler drive

1. Unscrew the fastening screws **-1-** and remove the cover with the pump unit **-Arrow A-** .

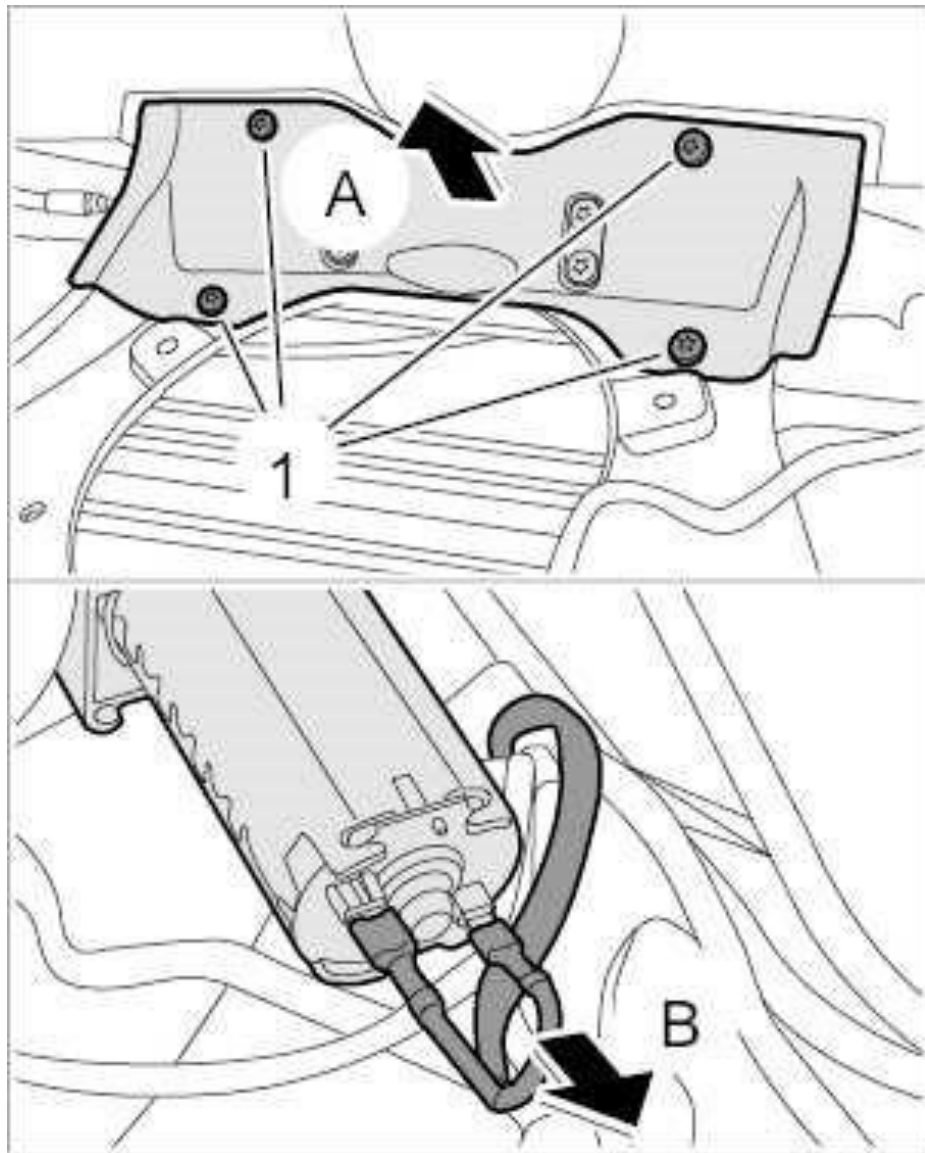

Loosening pump unit for spoiler drive

2. Pull off the two plug-in contacts **-Arrow B-** .

Removing wire harness for rear spoiler

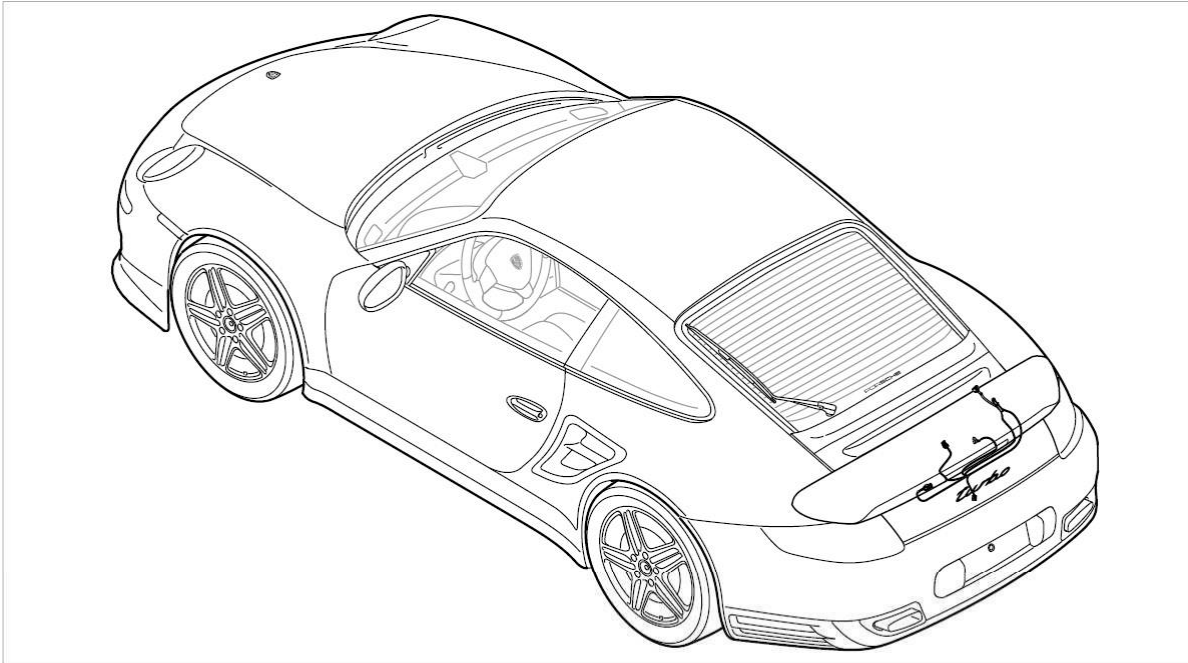

Installation position of wire harness for rear lid

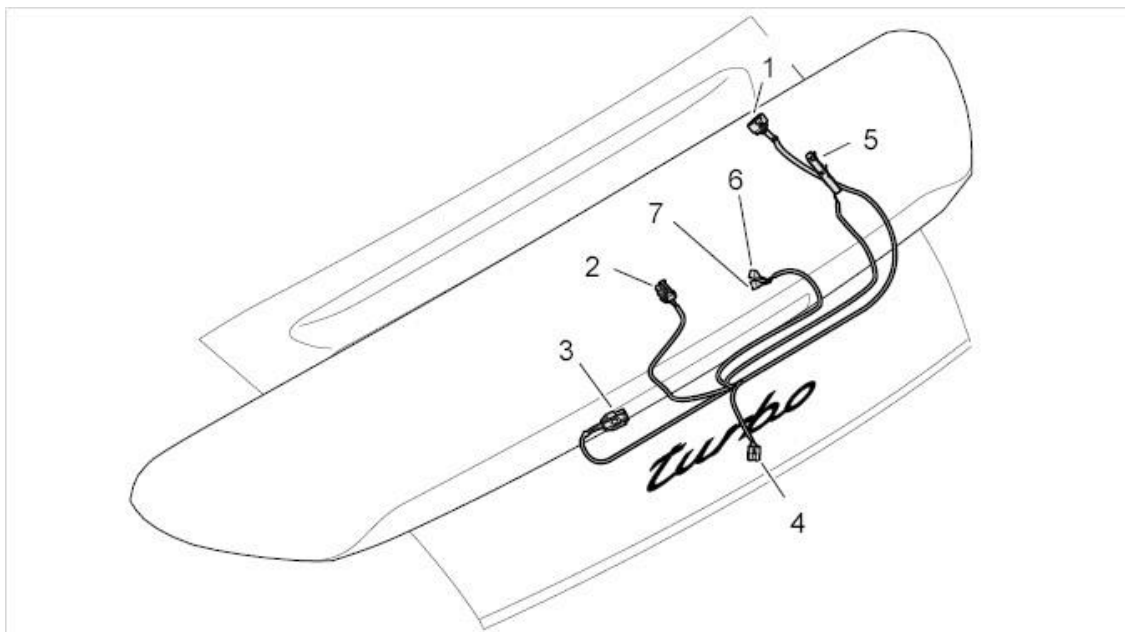

Overview of wire harness for rear lid

- 1 - Connector for main wire harness
- 2 - Connector for fan motor
- 3 - Connector for auxiliary brake light
- 4 - Connector for engine-compartment light
- 5 - Connector for hydraulic cylinder micro switch for rear spoiler
- 6 - Connector for pump unit ground lead for spoiler drive
- 7 - Connector for pump unit positive cable for spoiler drive

1. Unscrew the fastening screws -1- and take out the hydraulic cylinder.

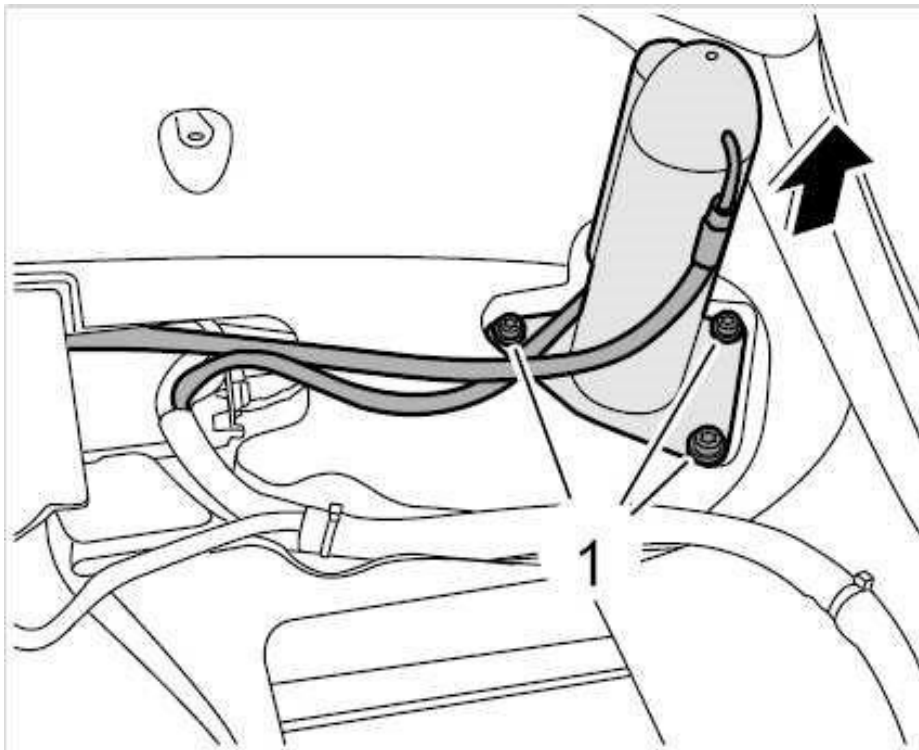

Loosening right hydraulic cylinder for rear spoiler

2. Lever off cover at points -a- using a screwdriver -**Arrow A**- and remove it -**Arrow B**- .

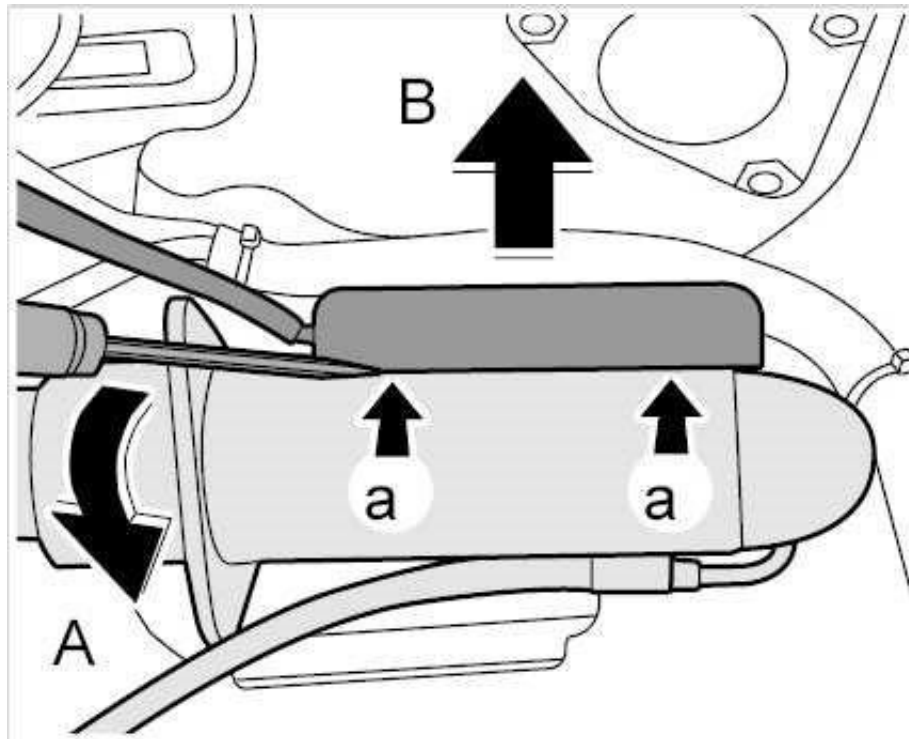

Removing micro switch cover on hydraulic cylinder

3. Screw out the fastening screws -1- and remove the holder with the micro switches.

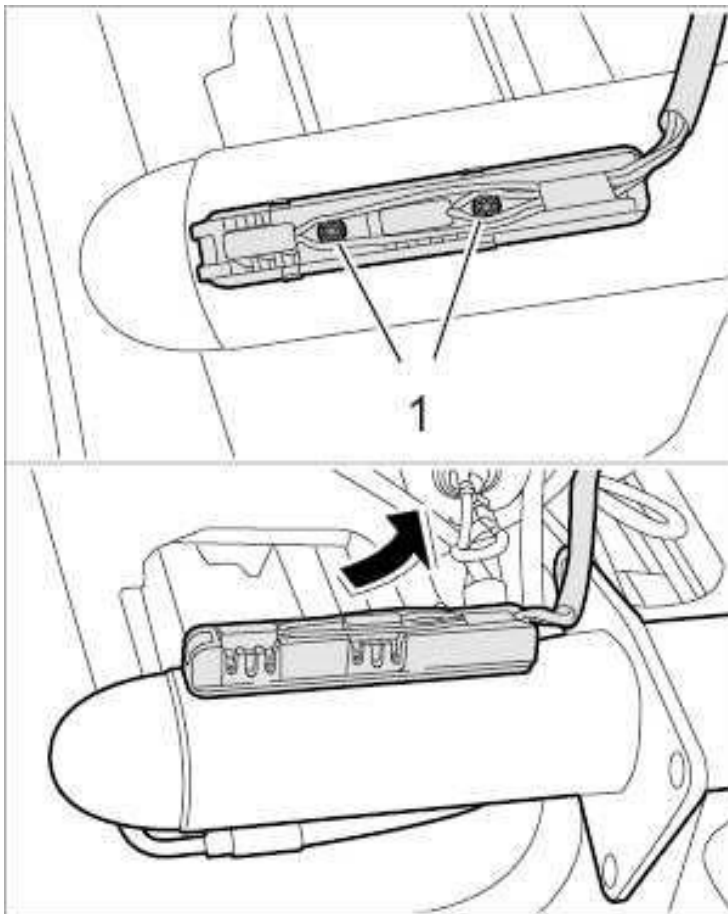

Removing micro switches from hydraulic cylinder

4. Unclip the wire harness using a plastic wedge **-Arrow A-** and remove it **-Arrow B-** .

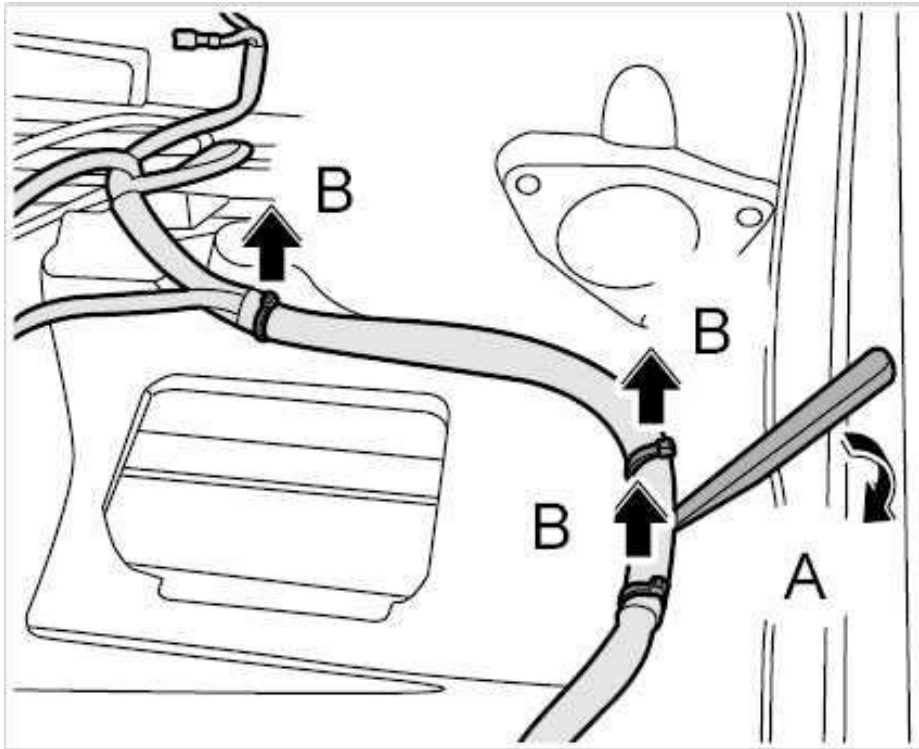

Unclipping wire harness for rear spoiler

Installing wire harness for rear spoiler

Installing wire harness for rear spoiler

1. Clip in the wire harness.

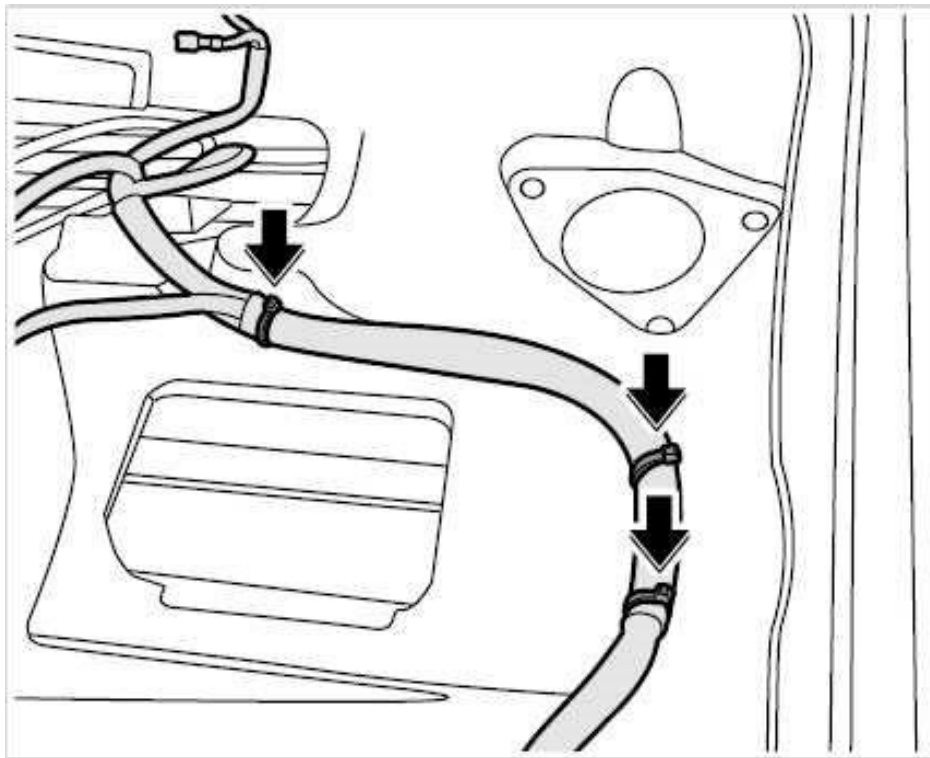

Clipping in wire harness for rear spoiler

2. Install auxiliary brake light. → 947019 *Removing and installing auxiliary brake light - section on "Installing"*

3. Install engine-compartment light. → 964319 *Removing and installing bulb for engine-compartment light - section on "Installing"*



Information

Make sure that pins **a** are inserted into the bores **b**.

4. Insert the holder with the micro switches into the hydraulic cylinder and secure with fastening screws **-1-** .

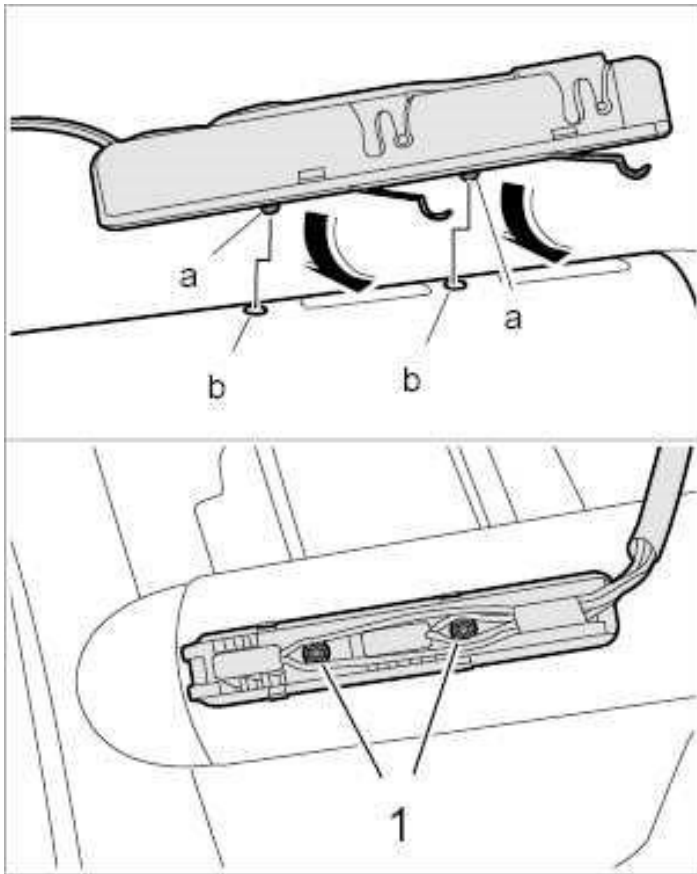

Securing micro switches on hydraulic cylinder

5. Press the cap onto the micro switches until it engages securely.

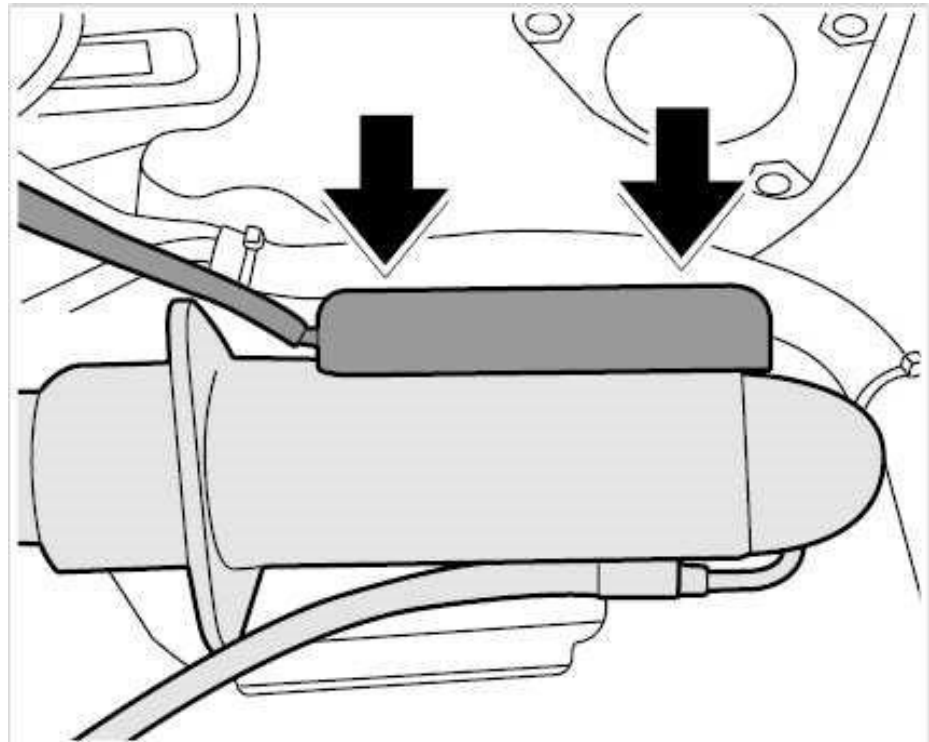

Fitting cap for micro switches

6. Place hydraulic cylinder in installation position and secure with fastening screws **-1-** .

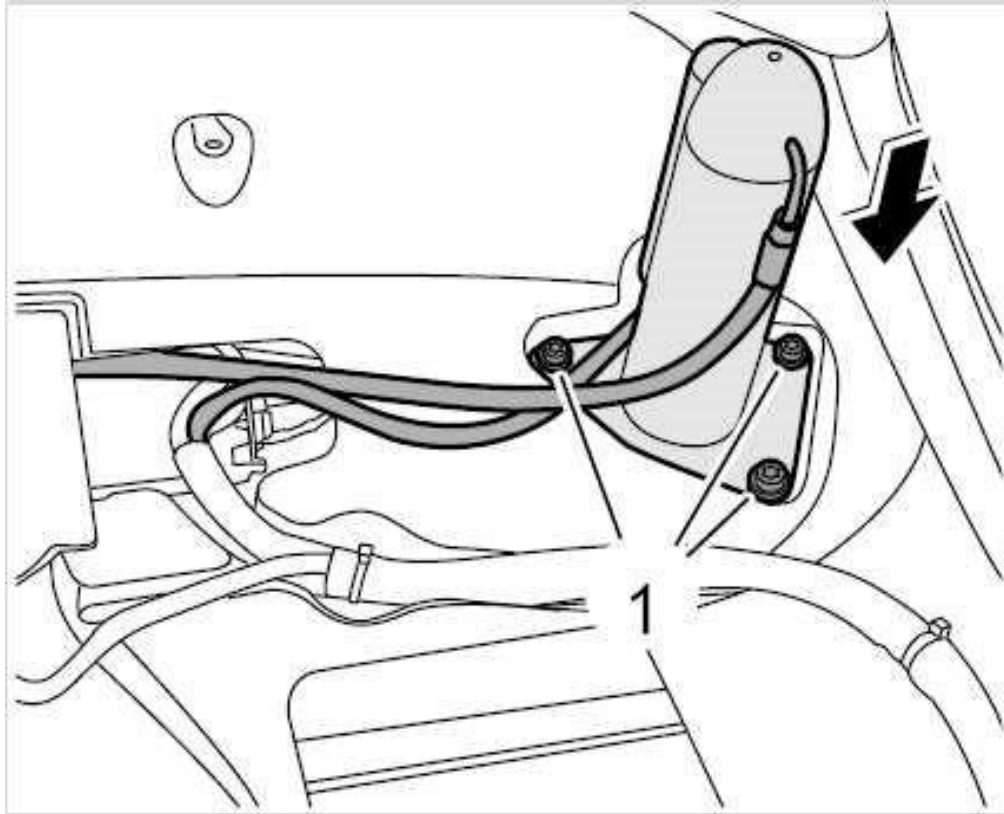

Securing right hydraulic cylinder for rear spoiler

Securing pump unit for spoiler drive

1. Connect the two electric lines to the pump unit **-Arrow A-** .

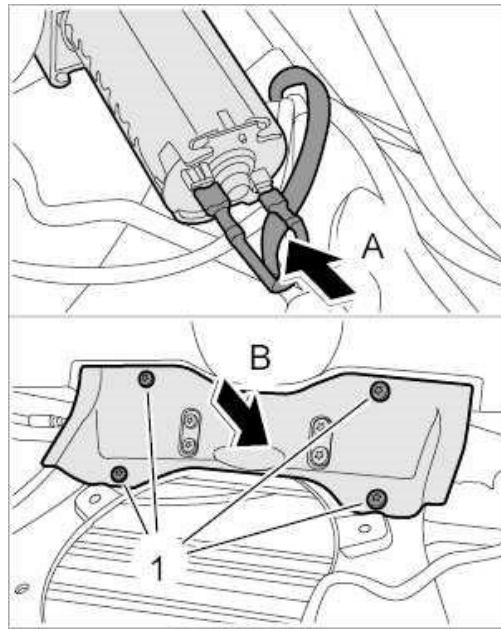

Securing pump unit for spoiler drive

2. Insert the cover with the pump unit **-Arrow B-** and secure with the fastening screws **-1-** .

Installing fan motor

1. Place the fan motor in installation position **-Arrow A-** and secure with the fastening screws **-1-** .

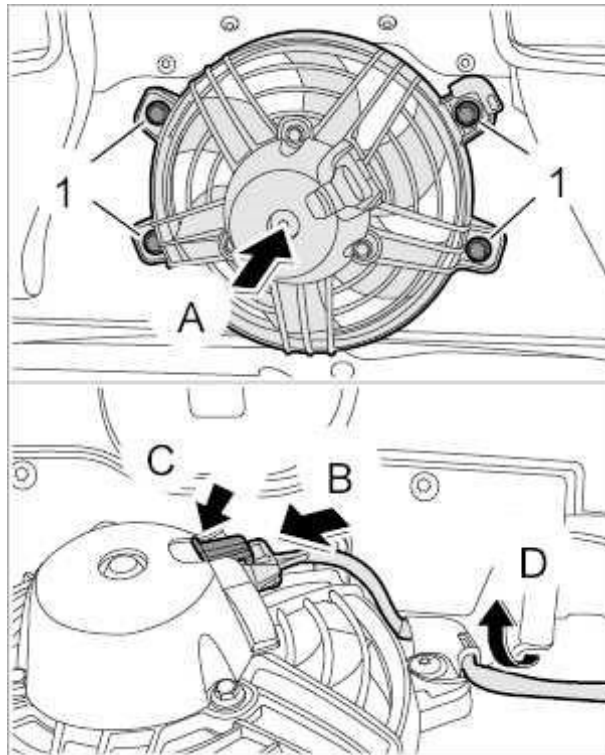

Securing fan motor on rear lid

2. Push on connector **-Arrow B-** until the locking lug **-C-** is felt to engage.
3. Insert the line into the holder **-Arrow D-** .

Installing air guide

1. Remove the remains of the old double-sided adhesive tape strips **-a-** and stick on strips of new doublesided adhesive tape.

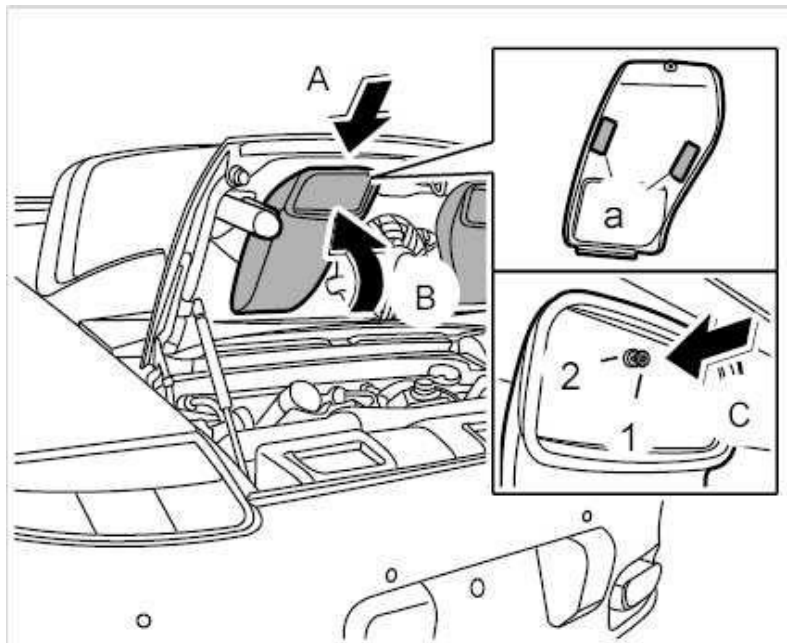

Installing air guides

2. Insert the air guides **-Arrow A-** and fold them up **-Arrow B-** .
3. Insert the clips **-2-** and then press in the screw-in pins **-1-** (**-Arrow C-**).

Connecting plug connection from rear lid to main wire harness

1. Connect the electric plug connection **-Arrow A-** until the locking lug **-1-** is felt to engage.

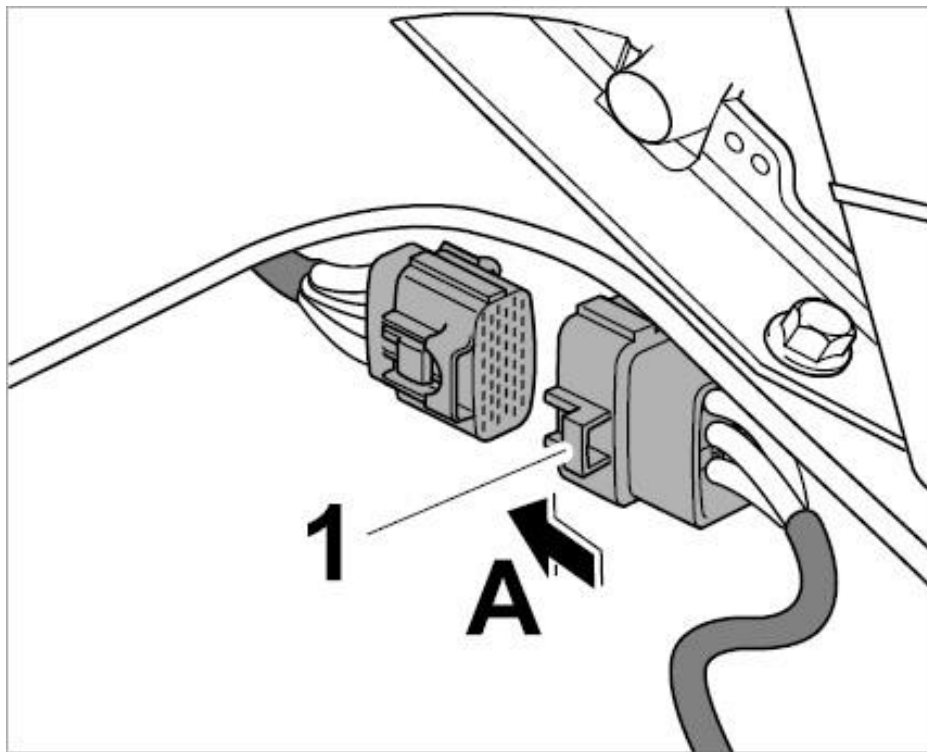

Locking wire harness on rear lid

2. Insert the wire harness into the wiring duct -**Arrow A**- .

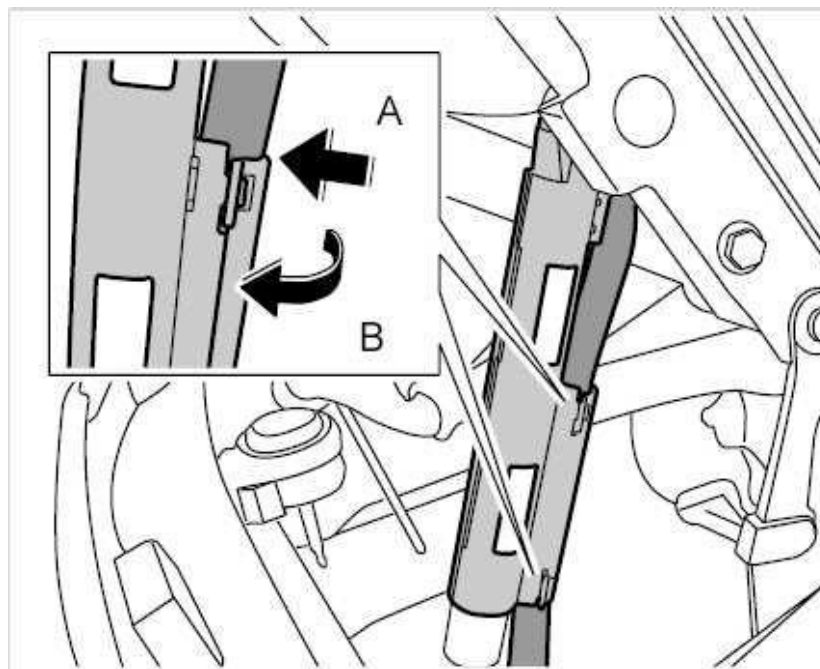

Securing line on hinge for rear lid

3. Close the wiring duct -**Arrow B**- until the locking lugs are felt to engage.

Subsequent work

Subsequent work

1. Install engine-compartment light. → *964319 Removing and installing bulb for engine-compartment light - section on "Installing"*
2. Install auxiliary brake light. → *947019 Removing and installing auxiliary brake light - section on "Installing"*
3. Install rear spoiler. → *665819 Removing and installing rear spoiler - section on "Installing"*