

PORSCHE

Turbo Coupe

US \$132,800

Model Year 2010 Standard Equipment includes:

Engine

500 hp, 480 lb ft torque - 3.8 liter horizontally opposed 6 cylinder with aluminum alloy engine block & cylinder heads, rear mounted engine. Twin Turbochargers with VTG (variable turbine geometry), twin intercoolers. Integrated dry sump lubrication system. 4 overhead camshafts, 4 valves per cylinder with "VarioCam Plus" continuously variable inlet valve timing and lift. Cylinder specific knock control. Stainless steel exhaust system with twin brushed steel tail pipes integrated in the rear apron.

Power Transmission

6-speed Manual Transmission with double inertia flywheel. Hydraulic clutch actuation. All wheel drive with map controlled multi disc clutch center differential and PTM (Porsche Traction Management).

Chassis and Suspension

8.5"x19" forged Turbo wheels, 235/35 ZR19 high performance tires - front. 11"x19" forged Turbo wheels, 305/30 ZR19 high performance tires – rear, includes anti-theft device. TPMS – Tire Pressure Monitoring System. Puncture sealing compound and electric compressor. Power assisted steering with variable ratio. McPherson strut suspension with stabilizer bar – front. Multi link LSA (Light, Stable, Agile) suspension with stabilizer bar – rear. PASM – (Porsche Active Suspension Management) including 10mm lowering. PSM – (Porsche Stability Management), with ABS (Anti lock Braking System), ASR (Anti Slip Regulation), ABD (Automatic Brake Differential) and EDTC (Engine Drag Torque Control).

Braking System

13.8" vented and perforated rotors w/ 6 piston monobloc fixed alloy calipers – front, 4 piston monobloc fixed alloy calipers – rear. ABS 8.0 – Anti Lock Braking System, brake pad wear indicators, hand operated parking brake. Calipers painted in red.

Body

Two plus two Coupe, body shell hot dip galvanized on both sides. Luggage compartment lid and doors in Aluminum. Electric sliding roof with tip open/close. Front apron with air intakes with Titanium tips. Rear side section with air intakes for charge-air intercoolers. Rear section with air outlets for charge-air intercoolers and high mounted and integrated tailpipes in chrome plated stainless steel. Side windows with water repellent coating. Heatable rear window. Automatically extendable rear spoiler. Chrome colored "Turbo" rear logotype. Metallic paint. Full underbody paneling. 17.7 gallon fuel tank.

Lighting System

Bi-Xenon lighting system with dynamic headlight leveling and headlight cleaning system. Welcome home function. Separate lights in front apron with LED-Indicator light and projector fog lights. Uniform lighting concept in white for entire interior, continuously variable. Footwell lighting.

Electrical Equipment

PCM (Porsche Communication Management) with 6.5" color display and full touchscreen controls. AM/FM radio with MP3 playing CD/DVD drive for audio playback. Bose Surround Sound System with 13 loudspeakers and 385 watts of total power. On board computer with boost pressure gauge, digital continuous indication of total mileage, trip mileage, time, outside temp and speed. 5 dial type gauges indicating RPM's, speed, oil pressure, oil temperature, coolant temp and fuel level, w/ aluminum colored dials. Electronic oil level measurement with map compensation. Power windows with tip up/tip down and anti-jamming. Automatically dimming interior and drivers side exterior mirrors. Two speed wiper system with rain sensor, wiper delay control, heated washer nozzles. Remote central locking w/ luggage compartment release. Anti theft system including passenger compartment monitoring. Homelink door opener, cruise control. Automatically dimming interior and drivers side exterior mirrors with rain sensor.

Passive Safety Equipment

Fully galvanized high strength steel body w/ front & rear deformation zones. 3 point seat belts w/ pre-tensioners and force limiters. Seat belt height adjustment. 2 stage driver/passenger airbags. Porsche Side Impact Protection System (POSIP) consisting of side impact protection elements in each door, thorax side airbags integrated in seat backrests, head airbags located in door trim. Preparation for child seat anchorage (ISOFIX) on passenger side w/ switch for airbag deactivation.

Interior Equipment

Fully electric seats including lumbar support with memory function on driver side. Split folding rear seats. 3 spoke steering wheel w/ manual reach and height adjustment. Leather interior, decorative stitching in light contrast color. Interior trim in soft-paint in interior color. Air vents, dashboard trim, trim surround on gear selector in aluminum look finish. Various interior parts in Volcano gray. Roof liner in Alcantara. Automatic climate control with integrated carbon filter. Two cup holders in front. Door storage bins. Door entry guards with "Turbo" logotype. Illuminated driver and passenger vanity mirrors.

Porsche Cars North America – United States Order Guide – 2010 Model Year
Options, Prices, content, and availability are subject to change without notice.

PORSCHE

Turbo Cabriolet

US \$143,800

Model Year 2010 Standard Equipment includes:

Engine

500 hp, 480 lb ft torque - 3.8 liter horizontally opposed 6 cylinder with aluminum alloy engine block & cylinder heads, rear mounted engine. Twin Turbochargers with VTG (variable turbine geometry), twin intercoolers. Integrated dry sump lubrication system. 4 overhead camshafts, 4 valves per cylinder with "VarioCam Plus" continuously variable inlet valve timing and lift. Cylinder specific knock control. Stainless steel exhaust system with twin brushed steel tail pipes integrated in the rear apron.

Power Transmission

6-speed Manual Transmission with double inertia flywheel. Hydraulic clutch actuation. All wheel drive with map controlled multi disc clutch center differential and PTM (Porsche Traction Management).

Chassis and Suspension

8.5"x19" forged Turbo wheels, 235/35 ZR19 high performance tires - front. 11"x19" forged Turbo wheels, 305/30 ZR19 high performance tires – rear, includes anti-theft device. TPMS – Tire Pressure Monitoring System. Puncture sealing compound and electric compressor. Power assisted steering with variable ratio. McPherson strut suspension with stabilizer bar – front. Multi link LSA (Light, Stable, Agile) suspension with stabilizer bar – rear. PASM – (Porsche Active Suspension Management) including 10mm lowering. PSM – (Porsche Stability Management), with ABS (Anti lock Braking System), ASR (Anti Slip Regulation), ABD (Automatic Brake Differential) and EDTC (Engine Drag Torque Control).

Braking System

13.8" vented and perforated rotors w/ 6 piston monobloc fixed alloy calipers – front, 4 piston monobloc fixed alloy calipers – rear. ABS 8.0 – Anti Lock Braking System, brake pad wear indicators, hand operated parking brake. Calipers painted in red.

Body

Two plus two Cabriolet, body shell hot dip galvanized on both sides. Luggage compartment lid and doors in Aluminum. Front apron with air intakes with Titanium tips. Rear side section with air intakes for charge-air intercoolers. Rear section with air outlets for charge-air intercoolers and high mounted and integrated tailpipes in chrome plated stainless steel. Side windows with water repellant coating. Heatable rear window. Automatically extendable rear spoiler. Windscreen. Chrome colored "Turbo" rear logotype. Metallic paint. Full underbody paneling. 17.7 gallon fuel tank.

Lighting System

Bi-Xenon lighting system with dynamic headlight leveling and headlight cleaning system. Welcome home function. Separate lights in front apron with LED-Indicator light and projector fog lights. Uniform lighting concept in white for entire interior, continuously variable. Footwell lighting.

Electrical Equipment

PCM (Porsche Communication Management) with 6.5" color display and full touchscreen controls. AM/FM radio with MP3 playing CD/DVD drive for audio playback. Bose Surround Sound System with 12 loudspeakers and 385 watts of total power. On board computer with boost pressure gauge, digital continuous indication of total mileage, trip mileage, time, outside temp and speed. 5 dial type gauges indicating RPM's, speed, oil pressure, oil temperature, coolant temp and fuel level, w/ aluminum colored dials. Electronic oil level measurement with map compensation. Power windows with tip up/tip down and anti-jamming. Electrically operated rear side windows. Electrically operated, fully-automatic folding cabriolet top with heated glass rear window. Automatically dimming interior and drivers side exterior mirrors. Two speed wiper system with rain sensor, wiper delay control, heated washer nozzles. Remote central locking w/ luggage compartment release. Anti theft system including passenger compartment monitoring. Homelink door opener, cruise control. Automatically dimming interior and drivers side exterior mirrors with rain sensor.

Passive Safety Equipment

Fully galvanized high strength steel body w/ front & rear deformation zones. 3 point seat belts w/ pre-tensioners and force limiters. Seat belt height adjustment. 2 stage driver/passenger airbags. Porsche Side Impact Protection System (POSIP) consisting of side impact protection elements in each door, thorax side airbags integrated in seat backrests, head airbags located in door trim. Preparation for child seat anchorage (ISOFIX) on passenger side w/ switch for airbag deactivation. Automatically deployed roll-over protection system.

Interior Equipment

Fully electric seats including lumbar support with memory function on driver side. Split folding rear seats. 3 spoke steering wheel w/ manual reach and height adjustment. Leather interior, decorative stitching in light contrast color. Interior trim in soft-paint in interior color. Air vents, dashboard trim, trim surround on gear selector in aluminum look finish. Various interior parts in Volcano gray. Roof liner in black. Automatic climate control with integrated carbon filter. Two cup holders in front. Door storage bins. Door entry guards with "Turbo" logotype. Illuminated driver and passenger vanity mirrors.

Porsche Cars North America – United States Order Guide – 2010 Model Year
Options, Prices, content, and availability are subject to change without notice.

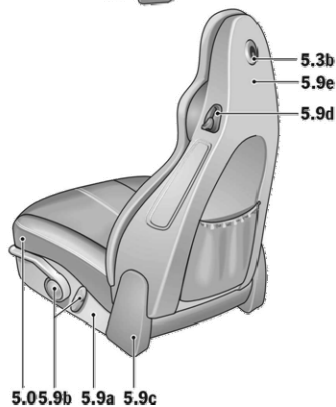
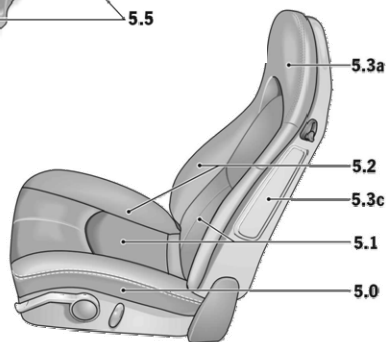
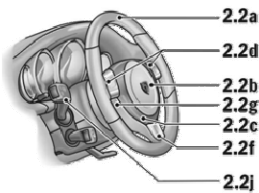
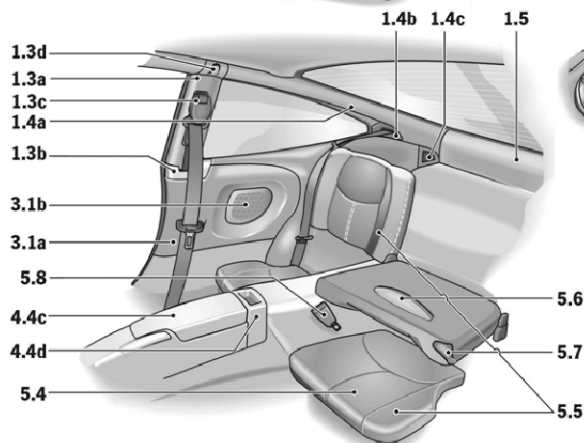
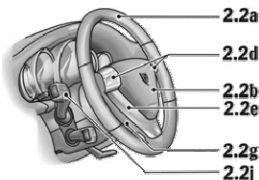
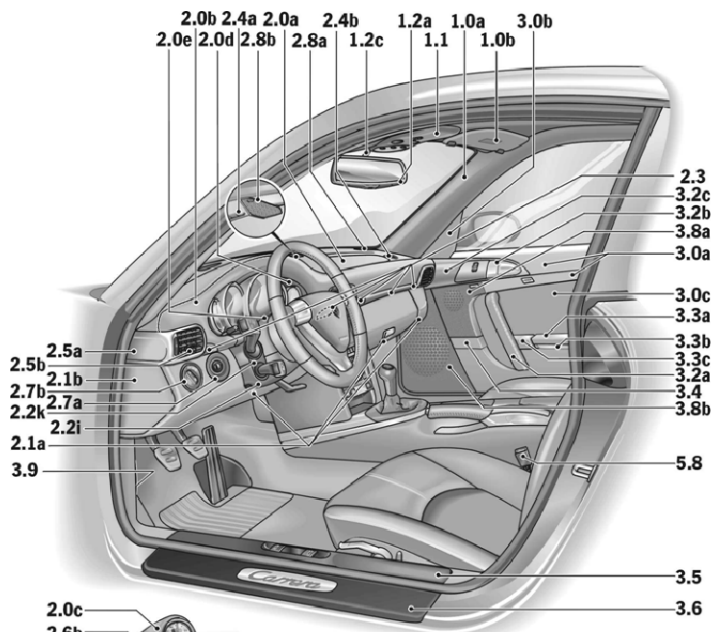

1.0a	A-pillar/windscreen frame trim
1.0b	Sun visors
1.1	Interior light surround
1.2a	Rear view mirror frame
1.2b	Rear view mirror casing
1.2c	Rear view mirror mounting
1.3a	B-pillar trim
1.3b	Belt outlets on B-pillars
1.3c	Belt height adjustment trim on B-pillars
1.3d	Clothes hook on B-pillars
1.4a	C-pillar trim
1.4b	Belt outlets on C-pillars
1.4c	Rear air vent
1.5	Rear panel trim
2.0a	Front part of dashboard incl. airbag cover
2.0b	Upper section of dashboard incl. instrument cover
2.0c	Timer cover
2.0d	Instrument surround
2.0e	Instrument surround lower section
2.1a	Lower section of dashboard incl. glove compartment, three-part
2.1b	Dashboard end trim
2.2a	Steering wheel rim
2.2b	Airbag module
2.2c	Airbag module surround on three-spoke sports steering wheel
2.2d	Tiptronic S switches (left/right) or spoke trim (left/right)
2.2e	"Y" trim on standard steering wheel
2.2f	Lower spoke trim on three-spoke sports steering wheel
2.2g	Steering wheel hub cover
2.2h	Steering wheel adjustment collar
2.2i	Steering column casing incl. hands-free microphone, three-part
2.2j	Control stalks
2.2k	Control stalk trim
2.3	Dashboard trim strip incl. cupholder trim, five-part
2.4a	Defroster trim
2.4b	Defroster air vent
2.5a	Side air vent
2.5b	Side air vent slats
2.6a	Central air vent incl. switch trim
2.6b	Central air vent slats
2.7a	Ignition lock surround
2.7b	Light switch surround
2.8a	Loudspeaker finishers on dashboard (left/right)
2.8b	Loudspeaker finisher on dashboard (center)
3.0a	Door trim incl. head-Airbag cover
3.0b	Mirror attachment point finishers incl. mirror controls and base plate
3.0c	Door panel
3.1a	Side trim, rear seat area
3.1b	Loudspeaker finishers at rear
3.2a	Front of door handle
3.2b	Door opener
3.2c	Door opener trim
3.3a	Lid of door storage bin
3.3b	Door storage bin surround
3.3c	Lid extension on door storage bin
3.4	Door panel trim
3.5	Inner door-sill guard
3.6	Outer door-sill guard
3.8a	Loudspeaker finishers (mid-tone) incl. seat memory trim (driver's side)
3.8b	Loudspeaker finishers (bass)
3.9	Fuse box trim
4.0a	Center console side trim, front
4.0b	PCM trim
4.0c	Climate control trim
4.0d	Lower center console trim
4.0e	Lower storage bin
4.1a	Gear lever or Tiptronic gear selector
4.1b	Gear lever trim
4.1c	Tiptronic gear selector gate surround
4.1d	Tiptronic gear selector gate
4.1e	Decorative trim on shift pattern or release of Tiptronic gear selector
4.2	Decorative trim on gear lever/selector
4.3a	Handbrake lever
4.3b	Handbrake finisher (upper section)
4.3c	Handbrake finisher (lower section)
4.4a	Rear section of center console incl. ashtray cover
4.4b	Handbrake lever recess trim
4.4c	Lid of storage bin in rear section of center console
4.4d	Storage tray rear section of center console
5.0	Seat base
5.1	Seat center, front
5.2	Lateral supports, front
5.3a	Integrated head restraints, front
5.3b	Clothes hook seat backrest
5.3c	Thorax airbag cover
5.4	Seat center, rear
5.5	Lateral supports, rear
5.6	Luggage stop on rear seat backrests
5.7	Release lever on rear seat backrests incl. base plate
5.8	Belt buckles (front/rear)
5.9a	Seat controls trim
5.9b	Seat controls
5.9c	Hinge cover
5.9d	Release lever surround
5.9e	Sports seat backrest

911

Revision 25.01.2007
VKI, MW

Order Guide

Option	Description	Must Pick	Required	Conflict	Model	Price (USD)
Standard Paint						
A1	Black				Turbo Coupe	\$0
					Turbo Cabriolet	\$0
B4	Carrara White				Turbo Coupe	\$0
					Turbo Cabriolet	\$0
G1	Guards Red				Turbo Coupe	\$0
					Turbo Cabriolet	\$0
X4	Speed Yellow				Turbo Coupe	\$0
					Turbo Cabriolet	\$0
Optional Metallic Paint						
9Q	Meteor Grey Metallic				Turbo Coupe	\$0
					Turbo Cabriolet	\$0
9S	Macadamia Metallic				Turbo Coupe	\$0
					Turbo Cabriolet	\$0
A6	Ruby Red Metallic				Turbo Coupe	\$0
					Turbo Cabriolet	\$0
D2	Aqua Blue Metallic				Turbo Coupe	\$0
					Turbo Cabriolet	\$0
J1	Porsche Racing Green Metallic				Turbo Coupe	\$0
					Turbo Cabriolet	\$0
N4	Dark Blue Metallic				Turbo Coupe	\$0
					Turbo Cabriolet	\$0
X1	Arctic Silver Metallic				Turbo Coupe	\$0
					Turbo Cabriolet	\$0
Z4	Basalt Black Metallic				Turbo Coupe	\$0
					Turbo Cabriolet	\$0

Option	Description	Must Pick	Required	Conflict	Model	Price (USD)
Special Paint						
8W	Nordic Gold Metallic				Turbo Coupe	\$3,140
					Turbo Cabriolet	\$3,140
E7	Atlas Grey Metallic				Turbo Coupe	\$3,140
					Turbo Cabriolet	\$3,140
H1	Malachite Green Metallic				Turbo Coupe	\$3,140
					Turbo Cabriolet	\$3,140
T2	Cream White				Turbo Coupe	\$3,140
					Turbo Cabriolet	\$3,140
U2	GT Silver Metallic				Turbo Coupe	\$3,140
					Turbo Cabriolet	\$3,140
Paint to Sample						
98	Non-Metallic Paint to Sample This option usually results in a production delay of 3 to 6 months. Not all color requests can be fulfilled and Porsche may require the customer or dealership to supply a paint sample or paint code in order to conduct feasibility testing. The deadline for submission of Model Year 2010 Paint to Sample orders will be approximately February 01, 2010.	24931	22291	789	Turbo Coupe	\$5,500
					Turbo Cabriolet	\$5,500
99	Metallic Paint to Sample This option usually results in a production delay of 3 to 6 months. Not all color requests can be fulfilled and Porsche may require the customer or dealership to supply a paint sample or paint code in order to conduct feasibility testing. The deadline for submission of Model Year 2010 Paint to Sample orders will be approximately February 01, 2010.	24931	22291	789	Turbo Coupe	\$5,500
					Turbo Cabriolet	\$5,500
Convertible Top Colors						
V3	Cabriolet roof in Stone Grey				Turbo Cabriolet	\$0
V4	Cabriolet roof in Metropol Blue				Turbo Cabriolet	\$0
V5	Cabriolet roof in Cocoa				Turbo Cabriolet	\$0
V9	Cabriolet roof in Black				Turbo Cabriolet	\$0

Option	Description	Must Pick	Required	Conflict	Model	Price (USD)
Leather for Sport Seats						
P77	Leather Sport Seats			P01 P03 541	Turbo Coupe	\$0
	Manual height and front/back adjustment. Power recline. Seatbacks in Volcano Grey.			982	Turbo Cabriolet	\$0
Full Leather						
AT	Black Full Leather				Turbo Coupe	\$0
					Turbo Cabriolet	\$0
DF	Stone Grey Full Leather				Turbo Coupe	\$0
					Turbo Cabriolet	\$0
FE	Sea Blue Full Leather				Turbo Coupe	\$0
					Turbo Cabriolet	\$0
TG	Sand Beige Full Leather				Turbo Coupe	\$0
					Turbo Cabriolet	\$0
Special Leather						
05	Dark Grey Natural Leather		998		Turbo Coupe	\$1,510
	Dark Grey Natural Leather with roofliner in Alcantara black.				Turbo Cabriolet	\$1,510
06	Brown Natural Leather		998	970	Turbo Coupe	\$1,510
	Brown Natural Leather with roofliner in Alcantara black.				Turbo Cabriolet	\$1,510
07	Carrera Red Natural Leather		998	970	Turbo Coupe	\$1,510
	Carrera Red Natural Leather with roofliner in Alcantara black.				Turbo Cabriolet	\$1,510
BK	Black/Stone Grey Interior		970		Turbo Coupe	\$430
	Black Leather: Windshield pillar and frame, B and C pillars, upper dash and instrument hump, steering wheel rim, top of door molding. Stone Grey Leather: Bottom Lower dash, side covers of center console, storage lid of center console, gearshift and handbrake lever, door handle, door pocket cover and frame, door center panel, rear side covering. Stone Grey Soft Paint: Dashboard end cover, rear center console, including ashtray lid handle recess cover, handbrake lever, storage box in rear center console, cover dashboard/frame PDK shift gate, loudspeaker cover, front loudspeaker cover, door pocket frame. Seats in Black leather. Sunvisors in Black. Carpeting in Stone Grey. Roofliner in Alcantara Black (Coupe).				Turbo Cabriolet	\$430

Option	Description	Must Pick	Required	Conflict	Model	Price (USD)
BM	Black/Sand Beige Interior Black Leather: Windshield pillar and frame, B and C pillars, upper dash and instrument hump, steering wheel rim, top of door molding. Sand Beige Leather: Lower dash, side covers of center console, storage lid of center console, gearshift and handbrake lever, door handle, door pocket cover and frame, door center panel, rear side covering. Sand Beige Soft Paint: Dashboard end cover, rear center console, including ashtray lid handle recess cover, handbrake lever, storage box in rear center console, cover of dashboard/frame PDK shift gate, loudspeaker cover, cover of front loudspeaker, door pocket frame. Seats in Black leather. Sunvisors in Black. Carpeting in Sand Beige. Roofliner in Alcantara Black (Coupe).		970		Turbo Coupe	\$430
					Turbo Cabriolet	\$430
BP	Black/Terracotta Interior Black Leather: Windshield pillar and frame, B and C pillars, upper dash and instrument hump, steering wheel rim, top of door molding. Terracotta Leather: Bottom dash, side covers of center console, storage lid of center console, gearshift and handbrake lever, door handle, door pocket cover and frame, door center panel, rear side covering. Soft Paint Terracotta: Dashboard end cover, rear center console, including ashtray lid handle recess cover, handbrake lever, storage box in rear center console, cover dashboard/frame PDK shift gate, loudspeaker cover, cover of front loudspeaker, door pocket frame. Seats in Black leather. Sunvisors in Black. Carpeting in Terracotta. Roofliner in Alcantara Black (Coupe).		970		Turbo Coupe	\$430
					Turbo Cabriolet	\$430
MB	Special Leather Terracotta Special Leather Terracotta interior with roofliner in Alcantara black.				Turbo Coupe	\$430
					Turbo Cabriolet	\$430
RA	Special Leather Cocoa Special Leather Cocoa interior with roofliner in Alcantara black.				Turbo Coupe	\$430
					Turbo Cabriolet	\$430
970	Two-tone Leather Interior This option is required when a Two-tone Leather interior (BM, BK, BP) is ordered.	BK BM BP		998	Turbo Coupe	\$0
					Turbo Cabriolet	\$0

Leather to Sample

99	Leather Interior to Sample This option usually results in a production delay of 3 to 6 months. An interior sketch is required. Not all leather requests can be fulfilled and Porsche may require the customer or dealership to supply a leather sample or previous interior code in order to conduct feasibility testing. The deadline for submission of Model Year 2010 Leather to Sample orders will be approximately February 01, 2010. Note: Loudspeaker grills (door and dash), steering wheel, and airbag cover in black. Steering wheel rim in black unless Exclusive options are ordered.	24941 00341 24961			Turbo Coupe	\$1,750
					Turbo Cabriolet	\$1,750

Option	Description	Must Pick	Required	Conflict	Model	Price (USD)
Floormats						
810	Floor Mats in Interior Color			CFX CJX	Turbo Coupe Turbo Cabriolet	\$150 \$150
CFX	Floor Mats With Colored Trim Set of four floor mats. Carpet in Black, Ocean Blue, Stone Grey, Sand Beige, Carrera Red, Terracotta, Cocoa or Natural Brown. Smooth leather surround, including double stitching.			CJX 810	Turbo Coupe Turbo Cabriolet	\$580 \$580
CJX	Floor Mats with Leather Surround Smooth leather surround including double stitching in color of carpet. Inlay on front floor mats in smooth leather in color of the leather surround with embossed Porsche logo and stitching.			CFX 810	Turbo Coupe Turbo Cabriolet	\$425 \$425
Seats						
342	Heated Seats Multi-stage heating system for front seats.			P03	Turbo Coupe Turbo Cabriolet	\$510 \$510
541	Seat Ventilation Seat ventilation for both front seats.		342	P01 P03 P77 982	Turbo Coupe Turbo Cabriolet	\$800 \$800
982	Supple Leather Front and Rear Soft ruffled leather on front and rear seat centers.		AT BK BM BP DF FE MB RA TG 05 06 07 99	P01 P03 P77	Turbo Coupe Turbo Cabriolet	\$470 \$470
P01	Adaptive Sports Seats with Driver Memory Sport seats with electric adjustment for all seat functions, adjustable side bolsters, memory function for seat, and mirrors. Includes lumbar adjustment on driver side. Seatbacks in Volcano Grey.			P03 P77 541 982	Turbo Coupe Turbo Cabriolet	\$1,145 \$1,145
P03	Sport Bucket Seats Adjustable forward and backward only.			P01 P77 XSA XSB XY 342 509 541 982	Turbo Coupe Turbo Cabriolet	\$2,990 \$2,990
XSC	Porsche Crest in Headrests Head restraints on front seats embossed with Porsche crest.				Turbo Coupe Turbo Cabriolet	\$285 \$285
Audio & Communications						
461	Rod Antenna External antenna to improve AM reception, mounted on front right fender.			686	Turbo Coupe Turbo Cabriolet	\$0 \$0

Option	Description	Must Pick	Required	Conflict	Model	Price (USD)
619	Bluetooth Interface for Mobile Phone Bluetooth Interface for hands free mobile phone use. Operation of basic phone functions on PCM or multi-function steering wheel (if applicable).			618 666	Turbo Coupe	\$695
					Turbo Cabriolet	\$695
635	Park Assist System Parking aid with four distance sensors integrated discreetly at rear of car.				Turbo Coupe	\$530
					Turbo Cabriolet	\$530
640	Sport Chrono Package Turbo Including Dynamic Engine Mounting Analog and digital chronometer, sport button in the center console and display in the PCM, also adds ability to adjust lighting, wipers, AC and door locking to suit personal preference. Additionally, adds dynamic engine mounting. In conjunction with PDK, includes Sports Plus button in center console to activate launch control function (Race start). Note: In conjunction with PDK, price is \$3830.				Turbo Coupe	\$3,470
					Turbo Cabriolet	\$3,470
641	Electronic Logbook Enables automatic acquisition of mileage, driving distance, date, time and address of starting point and destination at every trip including PC- software for data download and evaluation.				Turbo Coupe	\$650
					Turbo Cabriolet	\$650
671	PCM Voice Control Voice activation for navigation, telephone, and stereo functions. Available for customer specified orders only.				Turbo Coupe	\$595
					Turbo Cabriolet	\$595
686	XM Radio Allows reception of XM Satellite Radio and XM NavTraffic (for vehicles equipped with Navigation). Complimentary 3-month service included - after 3 months, subscription is required. Note: XM service is not available in Alaska or Hawaii.			461	Turbo Coupe	\$750
					Turbo Cabriolet	\$750
693	6-Disc CD/DVD Changer Integrated in PCM. Includes ability to play MP3 music files and Audio DVDs.				Turbo Coupe	\$650
					Turbo Cabriolet	\$650
870	Universal Audio Interface Includes connections for three audio source types - iPod, USB for memory stick with MP3 files, and auxiliary interface for other source. iPod and USB interfaces include operation via PCM.				Turbo Coupe	\$440
					Turbo Cabriolet	\$440

Technical

220	Porsche Torque Vectoring (PTV) Actively enhances the driving dynamics and stability by enabling variable distribution of engine torque to the rear wheels and mechanical limited-slip rear differential. Depending on the steering angle, steering speed, throttle pedal position, yaw velocity and vehicle speed, PTV optimizes steering response and precision by applying brake pressure to the left or right rear wheel as required.				Turbo Coupe	\$1,320
					Turbo Cabriolet	\$1,320

Option	Description	Must Pick	Required	Conflict	Model	Price (USD)	
250	7-speed Porsche Doppelkupplung (PDK) 7 speed Porsche Doppelkupplung (PDK) double clutch transmission with manual steering wheel speedshift and automatic transmission.			ECA ECC XCZ	Turbo Coupe	\$4,550	
				XDZ	Turbo Cabriolet	\$4,550	
425	Rear Window Wiper				Turbo Coupe	\$360	
450	Porsche Ceramic Composite Brake (PCCB) Porsche Ceramic Composite Brake (PCCB) system. Carbon-fiber reinforced ceramic brake discs, internally ventilated and perforated, with yellow painted brake calipers.			447	Turbo Coupe	\$8,840	
					Turbo Cabriolet	\$8,840	
509	Fire Extinguisher DIN EN3-compliant powder-based system containing 1 kg of extinguishant. Stows neatly beneath driver's seat.			P03	Turbo Coupe	\$140	
					Turbo Cabriolet	\$140	
549	Roof Transport System 165 lb. (75 kg) payload, can be used with all Porsche load carrier accessories.				Turbo Coupe	\$400	
550	Aluminum Hard Top Aluminum hardtop in exterior color with heated rear window. Black fabric lining on interior.				Turbo Cabriolet	\$3,490	
603	Dynamic Cornering Lights Headlights adjust dynamically based upon speed and turn angle.				Turbo Coupe	\$690	
					Turbo Cabriolet	\$690	
XCZ	Sport Shifter Reduces shift travel for highly efficient shifting. Note: only in conjunction with manual transmission. Only available for Customer specified orders.			250	Turbo Coupe	\$765	
					Turbo Cabriolet	\$765	
Wheels							
422	19 inch RS Spyder Wheel with Center Lock				Turbo Coupe	\$3,835	
					Turbo Cabriolet	\$3,835	
446	Wheel Caps with Colored Crest Wheel Caps with full-color Porsche Crest.				XDA XDB XDC	Turbo Coupe	\$185
					XDD XDE XD9 422	Turbo Cabriolet	\$185
CRX	Wheels Painted in Deviating Exterior Color Painted wheels (partially) and wheel centers including color Porsche crest in deviating exterior color. Note: Wheels painted in matching exterior color is only available as option XD9. Only available in standard and special colors.		422		XDA XDB XDC	Turbo Coupe	\$1,815
					XDD XDE XD9 446	Turbo Cabriolet	\$1,815

Option	Description	Must Pick	Required	Conflict	Model	Price (USD)	
XD9	Rims and Caps - Exterior Color Painted wheels and wheel centers with full-color Porsche crest.		422	X1 XDA XDB	Turbo Coupe	\$1,490	
				XDC XDD XDE 446	Turbo Cabriolet	\$1,490	
XDA	Wheels Painted Black		422	A1 XDB XDC	Turbo Coupe	\$1,815	
				XDD XDE XD9 446	Turbo Cabriolet	\$1,815	
XDB	Wheels Painted Basalt Black			Z4 XDA XDC	Turbo Coupe	\$1,815	
				XDD XDE XD9 422 446	Turbo Cabriolet	\$1,815	
XDC	Wheels Painted Speed Yellow			X4 XDA XDB	Turbo Coupe	\$1,815	
				XDD XDE XD9 422 446	Turbo Cabriolet	\$1,815	
XDD	Wheels Painted Carrara White			B4 XDA XDB	Turbo Coupe	\$1,815	
				XDC XDE XD9 422 446	Turbo Cabriolet	\$1,815	
XDE	Wheels Painted Guards Red			G1 XDA XDB	Turbo Coupe	\$1,815	
				XDC XDD XD9 422	Turbo Cabriolet	\$1,815	
Interior Options							
345	Heated Steering Wheel Heated steering wheel rim with control of heated seats via a button on the steering wheel.		342		Turbo Coupe	\$210	
					Turbo Cabriolet	\$210	
CEE	Rear Footwell Lighting Additional lights in rear footwell (left/right).				Turbo Coupe	\$415	
					Turbo Cabriolet	\$415	
CEF	LED Door Storage Pocket Lighting LED lighting in door storage bin (left/right).				Turbo Coupe	\$355	
					Turbo Cabriolet	\$355	
Interior Cosmetic							
X70	Door Entry Guards in Stainless Steel Door entry guards in stainless steel with Turbo logo.				XXB XXD X69	Turbo Coupe	\$415
					Turbo Cabriolet	\$415	
XFD	Instrument dials in Sand Beige Paint finish in Sand Beige				XFG XFH XFJ	Turbo Coupe	\$860
					Turbo Cabriolet	\$860	
XFG	Instrument dials in Guards Red Paint finish in Guards Red.				XFD XFH XFJ	Turbo Coupe	\$860
					Turbo Cabriolet	\$860	

Option	Description	Must Pick	Required	Conflict	Model	Price (USD)
XFH	Instrument dials in Speed Yellow Paint finish in Speed Yellow.			XFD XFG XFJ	Turbo Coupe	\$860
					Turbo Cabriolet	\$860
XFJ	Instrument dials in Carrara White Paint finish in Carrara White.			XFD XFG XFH	Turbo Coupe	\$860
					Turbo Cabriolet	\$860
XSH	Seat Belts in Silver Full set of belts for front and rear.			XST XSX XSY	Turbo Coupe	\$540
					Turbo Cabriolet	\$540
XST	Seat belts in Sand Beige Full set of belts for front and rear.			XSH XSX XSY	Turbo Coupe	\$540
					Turbo Cabriolet	\$540
XSX	Seat Belts in Guards Red Full set of belts for front and rear.			XSH XST XSY	Turbo Coupe	\$540
					Turbo Cabriolet	\$540
XSY	Seat Belts in Speed Yellow Full set of belts for front and rear.			XSH XST XSX	Turbo Coupe	\$540
					Turbo Cabriolet	\$540
XXB	Outer Door-sill Guards in Stainless Steel, Illuminated Outer door-sill guards[3.6] in stainless steel with Turbo logo, illuminated in white.		YES	XXD X69 X70	Turbo Coupe	\$845
					Turbo Cabriolet	\$845

Interior Options in Leather

840	3-spoke PDK Sports Steering Wheel with Shift Paddles The shift function and shift characteristics of the paddles have been largely adopted from the Porsche RS Spyder. The right-hand paddle is embossed with ?+? for upshifting and the left-hand one with ?-? for downshifting. The high-quality shift paddles are made from die-cast zinc . The shift paddles are sickleshaped and jut up above the steering wheel spokes. This long shape makes it possible to ensure manual gear changes across a wide range of steering wheel positions.		250	XPU 345 844 845 847	Turbo Coupe	\$490
					Turbo Cabriolet	\$490
844	3-Spoke Multifunction Steering Wheel in Smooth Leather Three spoke multifunction steering wheel with smooth leather finish in interior color and steering wheel rim with cross-stitched seam.			XPU 840 845 847	Turbo Coupe	\$0
					Turbo Cabriolet	\$0
EAF	Interior Leather Package Smooth leather in interior color on instrument surround, side air vents and slats, central air vent including switch trim and slats, and cover of door opener.			EAG EAH EAJ XCL XDP	Turbo Coupe	\$2,170
					Turbo Cabriolet	\$2,170
EAK	A-pillar Leather Interior Package Switch panel end trim[2.1b], ignition lock surround[2.7a], and mirror attachment point finishers[3.0b] in smooth leather finish in interior color. Includes decorative stitching where appropriate.				Turbo Coupe	\$740
					Turbo Cabriolet	\$740

Option	Description	Must Pick	Required	Conflict	Model	Price (USD)
XDU	Belt Outlet on B-Pillar in Leather Smooth leather finish in interior color on belt outlet on B-pillars[1.3b].			CDU XCW XDR XJJ	Turbo Coupe	\$215
					Turbo Cabriolet	\$215
XDZ	Gear Lever Trim in Leather			250	Turbo Coupe	\$260
					Turbo Cabriolet	\$260
XMA	Rooflining in Leather Rooflining in leather in interior color.				Turbo Coupe	\$1,180
XMP	Sun Visors in Leather Sun visors and vanity mirror covers in leather in interior color.				Turbo Coupe	\$560
					Turbo Cabriolet	\$560
XMZ	Rear Center Console in Leather Rear section of center console including ashtray cover[4.4a], storage tray rear section of center console[4.4d], handbrake lever recess trim[4.4b] in smooth leather finish in interior color.			XCK XJT XME XMJ	Turbo Coupe	\$1,260
					Turbo Cabriolet	\$1,260
XNG	Instrument Surround in Leather Instrument surround in leather finish in interior color.			EAJ XCL XDP	Turbo Coupe	\$440
					Turbo Cabriolet	\$440
XNS	Steering Column in Leather Steering column casing (three-part) in smooth leather finish in interior color.				Turbo Coupe Turbo Cabriolet	\$420 \$420
XPT	Porsche Crest on Center Console Storage Bin Lid			XLG XUV	Turbo Coupe Turbo Cabriolet	\$330 \$330
XSB	Sport Seat Backs in Leather Rear of backrests in smooth leather in interior color.	P01 P77		XSA	Turbo Coupe	\$1,870
					Turbo Cabriolet	\$1,870
XTG	Inner Sill Finishers in Leather Inner sill finishers in leather in interior color.				Turbo Coupe Turbo Cabriolet	\$585 \$585
XUV	Turbo Logo on Center Console Storage Bin Lid			XLG XPT	Turbo Coupe Turbo Cabriolet	\$330 \$330
XUX	Rear Seat Backrest Lever in Leather Rear seat backrest release lever[5.7], including baseplate, in smooth leather finish in interior color. Note: for Coupe models this part is contained in interior package C-pillar leather (option code DAC). Available from approximately 12/2009.				Turbo Coupe	\$310
					Turbo Cabriolet	\$310
XV1	Defroster Trim in Leather Defroster trim and loudspeaker finisher on switch panel in smooth leather finish in interior color, including decorative stitching where appropriate.			CDG CMG	Turbo Coupe	\$535
					Turbo Cabriolet	\$535

Option	Description	Must Pick	Required	Conflict	Model	Price (USD)
XVP	Dashboard Trim Strip in Leather Dashboard trim strip[five part, 2.3], including cupholder trim, in smooth leather finish in interior color.			XDM 801 803	Turbo Coupe	\$605
					Turbo Cabriolet	\$605
XVT	Door and Rear Loudspeaker Finishers in Leather Rear loudspeaker finishers[3.1b], door panel trim[3.4], mid-range loudspeaker finishers[3.8a], and bass loudspeaker finishers[3.8b] in smooth leather finish in interior color. Includes decorative stitching where appropriate.	AT BK BM BP DF FE TG MB RA 05 06 07 99			Turbo Coupe	\$2,570
					Turbo Cabriolet	\$2,570
XVW	Rear View Mirror in Leather Rear view mirror frame[1.2a], rear view mirror casing[1.2b], and rear view mirror mounting[1.2c] in smooth leather finish in interior color.				Turbo Coupe	\$675
					Turbo Cabriolet	\$675
XVY	Clothes Hook on Seat Backrest in Leather			P03	Turbo Coupe	\$250
					Turbo Cabriolet	\$250
XWU	PDK Gear Selector Gate Surround in Leather		250	XWR XWS XWT	Turbo Coupe	\$390
					Turbo Cabriolet	\$390
XZD	Dome Lamp Cover in Leather Interior light cover[1.1] in smooth leather finish in interior color.				Turbo Coupe	\$335
Custom Tailoring and Deviations - Leather						
CDT	Seat Belt Buckles in Leather Seat belt buckles featuring smooth leather finish in interior color, including decorative stitching where appropriate.				Turbo Coupe	\$760
					Turbo Cabriolet	\$760
CNB	Defroster Air Vents in Leather Smooth leather finish in interior color on defroster air vents. Soft touch paint finish in interior color on defroster air vent slats.				Turbo Coupe	\$365
					Turbo Cabriolet	\$365
CPU	Key Pouch in Interior Color Leather In smooth leather in interior color with embossed Porsche crest and decorative seam.				Turbo Coupe	\$95
					Turbo Cabriolet	\$95
CUJ	Fuse Box Cover in Leather Smooth leather finish in interior color on fuse box cover. Includes decorative stitching where appropriate.				Turbo Coupe	\$165
					Turbo Cabriolet	\$165
CUR	PCM Package Leather Smooth leather finish in interior color on PCM trim[4.0b], climate control trim[4.0c], lower switch trim[4.0d], lower storage bin[4.0e].			CCP CMF CUF	Turbo Coupe	\$2,225
					Turbo Cabriolet	\$2,225

Option	Description	Must Pick	Required	Conflict	Model	Price (USD)
CVD	Luggage Stop on Rear Seat Backrest in Leather Luggage stop on rear seat backrest with smooth leather finish in interior color including decorative stitching.			DAC	Turbo Coupe	\$275
CVZ	Bose Subwoofer Outlets in Leather Smooth leather finish in interior color.				Turbo Coupe	\$225
DAB	Interior Package B Pillar in Leather Leather finish interior color on belt outlet on B pillar, belt height adjustment trim on B pillars, clothes hook on B pillars, and clothes hook on seat backrest. Includes decorative stitching where appropriate.			CDU CVY	Turbo Coupe	\$965
DAC	Interior Package C Pillar in Leather Leather finish in interior color on belt outlet on C pillars, rear air vent, luggage stop on rear backrests, and release lever on rear seat backrest, including base plate. Includes decorative stitching where appropriate.			CUX CVD XUX	Turbo Coupe	\$1,035
DAW	Gear Lever and Handbrake Lever Aluminum/Leather Gear lever and handbrake in leather and aluminum. Valid only with interior to sample or when ordering deviating stitching.			DAT DAX ECA ECC XDZ 250 801 803	Turbo Coupe Turbo Cabriolet	\$2,130 \$2,130
DAZ	Customization Package-PDK Gear Selector and Handbrake Lever For use only in conjunction with Leather in Color to Sample and/or Deviating stitching. PDK Gear selector, PDK gear selector gate surround, and upper section of handbrake finisher in smooth leather in interior color. Handbrake lever in aluminum. Lower section of handbrake finisher in aluminum look.		250	CFP DAP XFP XWU 801 803	Turbo Coupe Turbo Cabriolet	\$2,390 \$2,390
Interior Options in Aluminum Look						
EAJ	Interior Aluminum Look Package Aluminum look paint finish on side air vents, central air vents including switch trim, instrument surround, front door handle, lid of door storage bin including lid extension on door storage bin, and door opener trim. Smooth leather finish in interior color on side air vent slats, and central air vent slats.			EAF EAG EAH XDP XNG XTV	Turbo Coupe Turbo Cabriolet	\$2,870 \$2,870
ECA	Gear Lever and Handbrake Lever in Aluminum Look Gear lever and handbrake lever (partially) in Aluminum. Smooth leather finish in interior color on inlays in gear lever and handbrake finisher (upper section). Aluminum Look paint finish on handbrake finisher (lower section).			ECB ECC XFP 250 801 803	Turbo Coupe Turbo Cabriolet	\$1,075 \$1,075

Option	Description	Must Pick	Required	Conflict	Model	Price (USD)
ECB	PDK Gear Selector and Handbrake Lever in Aluminum PDK gear selector and handbrake lever in aluminum. Upper section of handbrake finisher and inlays in PDK gear selector in smooth leather finish in interior color. Lower section of handbrake finisher in aluminum look paint finish. Note: leather pieces in black smooth leather finish when in conjunction with leather in color to sample.		250	ECA ECC XFP	<i>Turbo Coupe</i>	\$1,075
				801 803	<i>Turbo Cabriolet</i>	\$1,075
ECC	Gear Lever and Handbrake Lever in Aluminum Inlay in handbrake lever[4.3a] and part of gear lever[4.1a], including milled-in shift pattern, in aluminum. Handbrake lever and upper section of handbrake finisher[4.3b] in smooth leather finish in interior color. Lower section of handbrake finisher[4.3c] in aluminum look paint finish. Note: leather parts in black when in combination with leather in color to sample.			ECA ECB 250	<i>Turbo Coupe</i>	\$1,555
				801 803	<i>Turbo Cabriolet</i>	\$1,555
XCK	Rear Center Console in Aluminum Look Rear section of center console including ashtray cover storage tray rear section of center console in aluminum look painted finish. Handbrake lever recess trim in leather finish in interior color.			XJT XME XMJ	<i>Turbo Coupe</i>	\$730
				XMZ	<i>Turbo Cabriolet</i>	\$730
XCL	Instrument Surround in Aluminum Look			EAF XDP XNG	<i>Turbo Coupe</i>	\$440
					<i>Turbo Cabriolet</i>	\$440
XCW	B-Pillar Belt Outlets in Aluminum Look			CCW CDU XDR	<i>Turbo Coupe</i>	\$200
				XDU XJJ	<i>Turbo Cabriolet</i>	\$200
XFP	Handbrake Lever in Aluminum Handbrake lever inlay in aluminum look. Handbrake lever and upper section of handbrake finisher in smooth leather finish in interior color. Lower section of handbrake finisher in aluminum look paint finish. Note: leather parts in Black when in conjunction with leather in color to sample.	250	ECC	ECA ECB 801	<i>Turbo Coupe</i>	\$775
				803	<i>Turbo Cabriolet</i>	\$775
XPU	3-Spoke Multifunction Steering Wheel-Aluminum Look for PDK Steering wheel rim and steering wheel hub cover with smooth leather finish and inserts with aluminum look paint finish.		345	840 844 845	<i>Turbo Coupe</i>	\$365
				847	<i>Turbo Cabriolet</i>	\$365
XWR	PDK Gear Selector Gate Surround in Aluminum Look		250	XWS XWT XWU	<i>Turbo Coupe</i>	\$390
					<i>Turbo Cabriolet</i>	\$390
XXZ	Footrest in Aluminum Driver's side foot rest in aluminum and rubber.				<i>Turbo Coupe</i>	\$250
					<i>Turbo Cabriolet</i>	\$250

Option	Description	Must Pick	Required	Conflict	Model	Price (USD)
Custom Tailoring and Deviations - Aluminum Look						
CCP	PCM Package in Aluminum Look PCM trim[4.0b], climate control trim[4.0c], lower switch trim[4.0d], and lower storage bin[4.0e] in aluminum look paint finish.			CMF CUF CUR	Turbo Coupe Turbo Cabriolet	\$2,225 \$2,225
CDA	Air Vent Slats in Aluminum Look Aluminum look paint finish on side air vent slats and central air vent slats. Smooth leather finish in interior color on side air vents, central air vent including switch trim.			CDG CDN CMG CMN EAF EAG EAH EAJ	Turbo Coupe Turbo Cabriolet	\$1,010 \$1,010
CFP	Handbrake Lever in Aluminum II Inlay in handbrake lever in aluminum with Porsche logo. Handbrake lever and upper section of handbrake finisher in smooth leather finish in interior color including decorative stitching. Lower section of handbrake finisher in aluminum look paint finish. Note: Only available with stitching in deviating color.		250	DAP DAZ ECB XFP 801 803	Turbo Coupe Turbo Cabriolet	\$775 \$775
CMS	Sports Bucket Seat Belt Passage Aluminum Look		P03	CMT CMU	Turbo Coupe Turbo Cabriolet	\$655 \$655
CNC	Front Air Intakes in Aluminum Look			CNF XAF	Turbo Coupe Turbo Cabriolet	\$750 \$750
DAX	Gear Lever and Handbrake Lever in Aluminum with Customization Gear lever and handbrake lever in aluminum. Leather finish in color to sample (matching interior) and/or stitching in deviating color (matching other deviating stitching). Only available with Leather Interior to Sample or Deviating Stitching.			DAT DAW ECA ECC XDZ 250 801 803	Turbo Coupe Turbo Cabriolet	\$2,390 \$2,390
Interior Options in Carbon						
803	Carbon Package Dashboard trim strip[five-part, 2.3], gear lever/Tiptronic gear selector[4.1a], handbrake lever grip[4.3a] in carbon fiber finish.			ECA ECB ECC XDM XFP XVP 801	Turbo Coupe Turbo Cabriolet	\$1,040 \$1,040
845	3-Spoke Multifunction Steering Wheel in Carbon Three spoke multifunction steering wheel - smooth leather finish on steering wheel rim with carbon inlay.		345	P03 XPX 840 844 847	Turbo Coupe Turbo Cabriolet	\$365 \$365
EAH	Interior Carbon Package Carbon finish on side air vents, central air vent, front side door handles, lid of door storage bin including lid extension on door storage bin, and door opener trim. Smooth leather finish in interior color on side air vent slats, and central air vent slats, including switch trim.			EAF EAG EAJ	Turbo Coupe Turbo Cabriolet	\$4,830 \$4,830

Option	Description	Must Pick	Required	Conflict	Model	Price (USD)
X69	Door Entry Guards in Carbon Door entry guards in carbon with Turbo logo.			XXB XXD X70	Turbo Coupe	\$780
					Turbo Cabriolet	\$780
XJJ	Belt Outlets on B Pillars in Carbon			XCW XDR XDU	Turbo Coupe	\$450
					Turbo Cabriolet	\$450
XMJ	Rear Center Console Carbon Rear section of center console including ashtray cover, storage tray rear section of center console in carbon finish. Handbrake lever recess trim in leather finish in interior color.			XCK XJT XME XMZ	Turbo Coupe	\$1,625
					Turbo Cabriolet	\$1,625
XXD	Door Entry Guards in Carbon, Illuminated		XES	XXB X69 X70	Turbo Coupe Turbo Cabriolet	\$1,365 \$1,365

Interior Options in Alcantara

XLG	Lid of Storage Bin in Alcantara with Porsche Logo			XPT XUV	Turbo Coupe Turbo Cabriolet	\$490 \$490
------------	--	--	--	---------	--------------------------------	----------------

Customer Tailoring and Deviations - Alcantara

26221	Door Handle/Door Storage Compartment Lid Alcantara Black Door handle and door storage compartment lid, including lid extension, in Alcantara Black.	24903 25994 00481		EAG EAH EAJ 25256 25441 26111 970	Turbo Coupe	\$1,640
					Turbo Cabriolet	\$1,640
CLA	Steering Wheel in Alcantara Thicker steering wheel rim in Alcantara black with cross-stitched seam. Airbag module is not in Alcantara.			XPU 345 840 845 847	Turbo Coupe	\$1,105
					Turbo Cabriolet	\$1,105
CLE	Trim Strip Switch Panel in Alcantara Trim strip in Alcantara including cup holder.			CDM CMM XDM XVP 801 803	Turbo Coupe	\$775
					Turbo Cabriolet	\$775
DAP	PDK Gear Selector and Handbrake Lever in Alcantara PDK gear selector, handbrake lever, and handbrake finisher with Alcantara finish in Black, including decorative stitching where appropriate. Inlay in handbrake lever in Aluminum with Porsche logo. Handbrake finisher in Aluminum Look paint finish.		250	CFP DAZ XFP 801 803	Turbo Coupe	\$1,880
					Turbo Cabriolet	\$1,880
DAT	Gear and Handbrake Lever in Alcantara Alcantara finish in black with decorative stitching where appropriate on gear lever, handbrake lever, and handbrake finisher. Decorative trim on shift pattern including middle shift pattern and inlay in handbrake lever with Porsche Logo in aluminum. Aluminum look paint finish on handbrake finisher.			DAW DAX ECA ECC 250 801 803	Turbo Coupe	\$1,880
					Turbo Cabriolet	\$1,880

Option	Description	Must Pick	Required	Conflict	Model	Price (USD)
Interior Options in Dark Wood						
801	Makassar Package Dashboard trim strip[five-part, 2.3], gear lever/PDK gear selector, handbrake lever grip[4.3a] in Dark Makassar wood finish.			ECA ECB ECC XDM XFP XVP 803	Turbo Coupe Turbo Cabriolet	\$890 \$890
847	Multifunction Steering Wheel in Makassar Three spoke multifunction steering wheel with Makassar inlay and smooth leather finish steering wheel.		345	P03 XPU 840 844 845	Turbo Coupe Turbo Cabriolet	\$365 \$365
EAG	Interior Makassar Package Dark Makassar Matt Silk Finish on side air vents, central air vent, front side door handle, lid door storage bin including lid extension on door storage bin, and door opener trim. Smooth leather finish in interior color on side air vent slats, and central air vent slats, including switch trim.			EAF EAH EAJ	Turbo Coupe Turbo Cabriolet	\$4,830 \$4,830
XJT	Rear Center Console Makassar Dark makassar finish on rear section of center console, including ashtray cover and storage tray on rear section of center console. Leather finish in interior color on handbrake lever recess trim.			XCK XME XMJ XMZ	Turbo Coupe Turbo Cabriolet	\$1,625 \$1,625
Custom Tailoring and Deviations - Wood						
CFS	Belt Outlets on B Pillars in Makassar			CCW CDR CDU CJJ CMR XCW XDR XDU XJJ	Turbo Coupe Turbo Cabriolet	\$450 \$450
Interior Options in Exterior Color						
XME	Rear Center Console in Exterior Color Paint finish in exterior color on rear section of center console, including ashtray cover and storage tray rear on section of center console. Leather finish in interior color on handbrake lever recess trim.			XCK XJT XMJ XMZ	Turbo Coupe Turbo Cabriolet	\$730 \$730
XSA	Sport Seat Backs Painted in Exterior Color		P01 P77	98 99 XSB 789	Turbo Coupe Turbo Cabriolet	\$1,580 \$1,580
XWS	PDK Gear Selector Gate Surround Painted in Exterior Color		250	XWR XWT XWU	Turbo Coupe Turbo Cabriolet	\$390 \$390
Custom Tailoring and Deviations - Exterior Color						
CDG	Switch Panel Package Painted Exterior Color Side air vents central air vents including switch trim. Leather finish interior color: defroster trim, side air vent slats, central air vent slats.			CDA CDN CMG CMN EAF EAG EAH EAJ XV1	Turbo Coupe Turbo Cabriolet	\$2,030 \$2,030

Option	Description	Must Pick	Required	Conflict	Model	Price (USD)
CDH	Door Finishers Painted in Exterior Color Paint finish in exterior color on front of door handle and door opener trim. This option is recommended in conjunction in option CDR-Belt Outlet on B-Pillar Painted in Exterior Color.			CMH EAF EAG	Turbo Coupe	\$900
				EAH EAJ	Turbo Cabriolet	\$900
CDN	Air Vent Slats Painted in Exterior Color Paint finish in exterior color on side air vent slats and central air vent slats. Smooth leather finish in interior color on side air vents, central air vent including switch trim.			CDA CDG CMG	Turbo Coupe	\$1,010
				CMN EAF EAG EAH EAJ	Turbo Cabriolet	\$1,010
CMA	Exterior Mirror Attachment Point Finishers Painted Exterior Color Exterior mirror attachment point finishers painted in exterior color.				Turbo Coupe	\$500
					Turbo Cabriolet	\$500
CMC	Door Opener Painted in Exterior Color			CDC	Turbo Coupe	\$550
					Turbo Cabriolet	\$550
CME	Rear Section of Center Console Painted in Deviating Color Paint finish in exterior color on rear section of center console including ashtray cover and storage tray in rear section of center console. Smooth leather finish in interior color on handbrake lever recess trim. Note: Rear section of center console with paint finish in matching exterior color is only available as option XME.			CMD XCK XJT	Turbo Coupe	\$1,130
				XME XMJ XMZ	Turbo Cabriolet	\$1,130
CNF	Front Air Intakes Painted Exterior Color			CNC XAF	Turbo Coupe	\$750
					Turbo Cabriolet	\$750
CUF	PCM Package Painted Paint finish in exterior color on PCM trim[4.0b], climate control trim[4.0c], lower switch trim[4.0d], lower storage bin[4.0e].			CCP CMF CUR	Turbo Coupe	\$2,225
					Turbo Cabriolet	\$2,225
XDJ	Gear Lever Trim in Exterior Color Paint finish in exterior color on decorative trim on gear lever/selector[4.2].				Turbo Coupe	\$295
					Turbo Cabriolet	\$295
XDM	Trim Strip Painted in Exterior Color			XVP 801 803	Turbo Coupe	\$520
					Turbo Cabriolet	\$520
XDP	Instrument Surround Painted in Exterior Color			EAF EAJ XCL	Turbo Coupe	\$440
				XNG	Turbo Cabriolet	\$440
XDR	Belt Outlet on B-pillars Painted in Exterior Color			XCW XDU XJJ	Turbo Coupe	\$200
					Turbo Cabriolet	\$200

Option	Description	Must Pick	Required	Conflict	Model	Price (USD)
Custom Tailoring and Deviations - Black						
CDC	Door Opener Painted Black			CMC	Turbo Coupe Turbo Cabriolet	\$550 \$550
CMD	Rear Center Console Painted Black Paint finish in Black on rear section of center console, including ashtray cover, and storage tray on rear section of center console. Smooth leather finish in interior color on handbrake lever recess trim.			CME XCK XJT XME XMJ XMZ	Turbo Coupe Turbo Cabriolet	\$1,130 \$1,130
CMF	PCM Package in Black PCM trim[4.0b], climate control trim[4.0c], lower switch trim[4.0d], and lower storage bin[4.0e] in black paint finish.			CCP CUF CUR	Turbo Coupe Turbo Cabriolet	\$2,225 \$2,225
CMG	Switch Panel Package Painted Black Side air vents and central air vents including switch trim painted black. Leather finish interior color on defroster trim, side air vent slats and central air vent slats.			CDA CDG CDN CMN EAF EAG EAH EAJ XV1	Turbo Coupe Turbo Cabriolet	\$2,030 \$2,030
CMH	Door Finishers Painted Black Paint finish in Black on front of door handle and door opener trim. Note: recommended in conjunction with belt-outlet B-pillars painted Black.			CDH EAF EAG EAH EAJ	Turbo Coupe Turbo Cabriolet	\$900 \$900
CMJ	Gear Lever/Selector Trim Painted Black			CDJ XDJ	Turbo Coupe Turbo Cabriolet	\$295 \$295
CMM	Trim Strip Painted Black Paint finish in Black on trim strip switch panel including cupholder trim (five-part).			CDM CLE XDM XVP 801 803	Turbo Coupe Turbo Cabriolet	\$520 \$520
CMN	Air Vent Slats Painted Black Paint finish in Black on side air vent slats and central air vent slats. Smooth leather finish in interior color on side air vents and central air vent including switch trim.			CDA CDG CDN CMG EAF EAG EAH EAJ	Turbo Coupe Turbo Cabriolet	\$1,010 \$1,010
CMP	Instrument Surround Painted Black			CDP EAF EAJ XCL XDP XNG	Turbo Coupe Turbo Cabriolet	\$440 \$440
CMR	Belt Outlets on B-Pillars Painted Black			CCW CDR CDU CFS CJJ XCW XDR XDU XJJ	Turbo Coupe Turbo Cabriolet	\$200 \$200
CMU	Sport Bucket Seat Belt Passage in Black		P03	CMS CMT	Turbo Coupe Turbo Cabriolet	\$655 \$655

Option	Description	Must Pick	Required	Conflict	Model	Price (USD)
XWT	PDK Gear Selector Gate Surround in Black		250	XWR XWS XWU	Turbo Coupe Turbo Cabriolet	\$390 \$390
Custom Tailoring and Deviations - Other						
00471	Back Of Rear Seats Deviating Carpet	25241			Turbo Coupe	\$0
	Rear side of back seat backrest covered with carpet	25351 25352			Turbo Cabriolet	\$0
09991	All Exclusive Options with Deviating Stitching			970	Turbo Coupe Turbo Cabriolet	\$290 \$290
24891	Stitching of Front and Rear Seats in Deviating Color			25991 970	Turbo Coupe Turbo Cabriolet	\$1,100 \$1,100
24901	Stitching of Dashboard in Deviating Color	AT BK BM BP DF FE TG MB RA 05 06 07 99		25992 970	Turbo Coupe Turbo Cabriolet	\$310 \$310
24902	Stitching of Door Trim in Deviating Color	AT BK BM BP DF FE TG MB RA 05 06 07 99		25993 970	Turbo Coupe Turbo Cabriolet	\$310 \$310
24903	Stitching of Door Handle in Deviating Color	AT BK BM BP DF FE TG MB RA 05 06 07 99		EAG EAH EAJ 25994 970	Turbo Coupe Turbo Cabriolet	\$550 \$550
	Stitching of door handles and door storage compartment lid in deviating thread color.					
24904	Stitching of Side Center Console in Deviating Color	AT BK BM BP DF FE TG MB RA 05 06 07 99		25995 970	Turbo Coupe Turbo Cabriolet	\$310 \$310
24905	Stitching of Rear Side Panel in Deviating Color	AT BK BM BP DF FE TG MB RA 05 06 07 99		25996 970	Turbo Coupe Turbo Cabriolet	\$390 \$390
24921	Upper Dash in Deviating Color	24901		25731 640	Turbo Coupe	\$470
	Dashboard upper section and passenger airbag standard leather in deviating color.	25992 00481		970	Turbo Cabriolet	\$470
24922	Lower Dash in Deviating Color	AT BK BM BP DF FE TG MB RA 05 06 07 99		25252 970	Turbo Coupe Turbo Cabriolet	\$310 \$310
	Dashboard lower section and glove compartment lid standard leather in deviating color.					

Option	Description	Must Pick	Required	Conflict	Model	Price (USD)
24923	Center Console Side Pads Standard Leather Deviating Color	24904		24924 25257	Turbo Coupe	\$160
		25995 00481		618 669 970	Turbo Cabriolet	\$160
24951	Carpet in Deviating Color			99 24961	Turbo Coupe	\$710
					Turbo Cabriolet	\$710
24961	Standard Carpet in Deviating Color Deviating carpet out of standard offering, only with Interior code '99'		99	24951	Turbo Coupe	\$0
					Turbo Cabriolet	\$0
25221	Roofliner Deviating Color Alcantara			XMA	Turbo Coupe	\$310
25231	Front Seat Inlay in Alcantara Deviating Color			25241 25251	Turbo Coupe	\$630
				25351 25352	Turbo Cabriolet	\$630
				25491 541		
				970 982		
25241	Front and Rear Seats in Leather Deviating Color	AT BK BM BP	00471	25231 25251	Turbo Coupe	\$1,500
		DF FE TG MB		25351 25352	Turbo Cabriolet	\$1,500
		RA 05 06 07		25491 970		
		99				
25281	Door Airbag Cover Trim Strip Leather Deviating Color	AT BK BM BP		25253 970	Turbo Coupe	\$310
		DF FE TG MB			Turbo Cabriolet	\$310
		RA 05 06 07				
		99				
25432	Storage Compartment Lid-Rear Center Console Leather Dev Color Storage compartment lid on rear of center console in standard leather deviating color.	AT BK BM BP		970	Turbo Coupe	\$160
		DF FE TG MB			Turbo Cabriolet	\$160
		RA 05 06 07				
		99				
25461	A/B/C Pillars in Standard Leather	AT BK BM BP		970	Turbo Coupe	\$790
		DF FE TG MB				
		RA 05 06 07				
		99				
25491	Front and Rear Seat Inlays In Deviating Color	AT BK BM BP		25231 25241	Turbo Coupe	\$1,180
		DF FE TG MB		25251 25351	Turbo Cabriolet	\$1,180
		RA 05 06 07		25352 970		
		99				
25631	Door Trim Standard Leather Deviating Color	24902		970	Turbo Coupe	\$310
		25993 00481			Turbo Cabriolet	\$310

Option	Description	Must Pick	Required	Conflict	Model	Price (USD)
25731 Upper Dash with Sport Chrono Deviating Color	Dashboard upper section and passenger airbag standard leather in deviating color.	24901	640	24921 970	Turbo Coupe	\$550
		25992 00481			Turbo Cabriolet	\$550
25961 Door Center Panel in Standard Leather, Deviating Color		AT BK BM BP		25254 970	Turbo Coupe	\$310
		DF FE TG MB RA 05 06 07 99			Turbo Cabriolet	\$310
26061 Steering Wheel Standard Leather Deviating Color		AT BK BM BP	26071	26271 840 970	Turbo Coupe	\$160
		DF FE TG MB RA 05 06 07 99			Turbo Cabriolet	\$160
26071 Steering Wheel Airbag Module Standard Leather, Deviating Color		AT BK BM BP		970	Turbo Coupe	\$160
		DF FE TG MB RA 05 06 07 99			Turbo Cabriolet	\$160
26111 Door Pull Handle & Storage Compartment Lid Leather Dev Color	Door Pull Handle/Storage Compartment Lid Leather Dev Color	24903		EAG EAH EAJ 25256 25441 26221 970	Turbo Coupe	\$470
		25994 00481			Turbo Cabriolet	\$470
26121 Door center panel in Black Alcantara		AT BK BM BP		25254 25961 970	Turbo Coupe	\$310
		DF FE TG MB RA 05 06 07 99			Turbo Cabriolet	\$310
26271 Steering Wheel in Standard Leather Deviating Color (PDK)		AT BK BM BP	840 26071	26061 970	Turbo Coupe	\$160
		DF FE TG MB RA 05 06 07 99			Turbo Cabriolet	\$160
CGD Sport Chrono Timer Display Painted Sand Beige			640	CGG CGH CGJ	Turbo Coupe	\$500
					Turbo Cabriolet	\$500
CGG Sport Chrono Timer Display Painted Guards Red			640	CGD CGH CGJ	Turbo Coupe	\$500
					Turbo Cabriolet	\$500
CGH Sport Chrono Timer Display Painted Speed Yellow			640	CGD CGG CGJ	Turbo Coupe	\$500
					Turbo Cabriolet	\$500
CGJ Sport Chrono Timer Display Painted Carrara White			640	CGD CGG CGH	Turbo Coupe	\$500
					Turbo Cabriolet	\$500

Option	Description	Must Pick	Required	Conflict	Model	Price (USD)
CMX	Side Strips with Model Designation Side strips with Turbologo, available in Guards Red, Speed Yellow, Black, Aluminum Look, Carrara White, Orange, Green, Dark Blue or Meteor Grey.				Turbo Coupe	\$775
					Turbo Cabriolet	\$775
CUL	Wind Deflector with Colored Porsche Logo Wind deflector with Porsche logo in choice of Carrara White, Guards Red, Arctic Silver, and Speed Yellow.				Turbo Cabriolet	\$225
Exterior Cosmetic						
498	Delete Model Designation			XUC	Turbo Coupe	\$0
					Turbo Cabriolet	\$0
XAF	Aerokit Turbo Includes new front spoiler lip, new engine cover with rear spoiler and fixed wing profile. Paint finish in exterior color, including standard side skirts and standard lower part of rear apron. Note: substantially reduces entry angle to gradients		CMZ	XAJ	Turbo Coupe	\$6,950
XAJ	Side Skirts in Painted in Exterior Color				Turbo Coupe	\$750
					Turbo Cabriolet	\$750
XUA	Spoiler Lip Painted				Turbo Coupe	\$640
					Turbo Cabriolet	\$640
XUB	Headlight Cleaner cover in Exterior Color				Turbo Coupe	\$295
					Turbo Cabriolet	\$295
XUC	Model Designation on Rear Lid in Exterior Color			498	Turbo Coupe	\$200
					Turbo Cabriolet	\$200
XUZ	Wing Mirror in Aluminum Look Lower part of wing mirror shell in aluminum look paint finish.				Turbo Coupe	\$550
					Turbo Cabriolet	\$550