

PORSCHE®

Turbo Coupe

US \$126,200

Model Year 2008 Standard Equipment includes:

Engine

480 hp, 460 lb ft torque - 3.6 liter horizontally opposed 6 cylinder with aluminum alloy engine block & cylinder heads, rear mounted engine. Twin Turbochargers with VTG (variable turbine geometry), twin intercoolers. Dry sump lubrication system with 9 oil pumps, external oil tank. 4 overhead camshafts, 4 valves per cylinder with "VarioCam Plus" continuously variable inlet valve timing and lift. Cylinder specific knock control. Stainless steel exhaust system with twin brushed steel tail pipes integrated in the rear apron.

Power Transmission

6-speed Manual Transmission with double inertia flywheel. Hydraulic clutch actuation. All wheel drive with map controlled multi disc clutch center differential and PTM (Porsche Traction Management).

Chassis and Suspension

8.5"x19" forged Turbo wheels, 235/35 ZR19 high performance tires - front. 11"x19" forged Turbo wheels, 305/30 ZR19 high performance tires – rear, includes anti-theft device. TPMS – Tire Pressure Monitoring System. Puncture sealing compound and electric compressor. Power assisted steering with variable ratio. McPherson strut suspension with stabilizer bar – front. Multi link LSA (Light, Stable, Agile) suspension with stabilizer bar – rear. PASM – (Porsche Active Suspension Management) including 10mm lowering. PSM – (Porsche Stability Management), with ABS (Anti lock Braking System), ASR (Anti Slip Regulation), ABD (Automatic Brake Differential) and EDTC (Engine Drag Torque Control).

Braking System

13.8" vented and perforated rotors w/ 6 piston monobloc fixed alloy calipers – front, 4 piston monobloc fixed alloy calipers – rear. ABS 8.0 – Anti Lock Braking System, brake pad wear indicators, hand operated parking brake. Calipers painted in red.

Body

Two plus two Coupe, body shell hot dip galvanized on both sides. Luggage compartment lid and doors in Aluminum. Electric sliding roof with tip open/close. Front apron with air intakes, front lights, indicators and fog lights. Rear side section with air intakes for charge-air intercoolers. Rear section with air outlets for charge-air intercoolers and high mounted and integrated tailpipes in chrome plated stainless steel. Side windows with water repellent coating. Heat able rear window. Automatically extendable rear spoiler. Chrome colored "Turbo" rear logotype. Metallic paint. Full underbody paneling. 17.7 gallon fuel tank.

Lighting System

Bi-Xenon lighting system with dynamic headlight leveling and headlight cleaning system. Welcome home function. Separate lights in front apron with LED-Indicator light and projector fog lights. Uniform lighting concept in white for entire interior, continuously variable. Foot well lighting.

Electrical Equipment

PCM (Porsche Communication Management) with 5.8" color display, 12 digit keypad, GPS navigation module for PCM with DVD drive in luggage compartment. AM/FM/CD radio with MP3-able CD drive for audio CD's. Bose Surround Sound System with 13 loudspeakers and 325 watt total power. On board computer with boost pressure gauge, digital continuous indication of total mileage, trip mileage, time, outside temp and speed. 5 dial type gauges indicating RPM's, speed, oil pressure, oil temperature, coolant temp and fuel level, w/ aluminum colored dials. Electronic oil level measurement with map compensation. Power windows with tip up/tip down and anti-jamming. Automatically dimming interior and drivers side exterior mirrors. Two speed wiper system with rain sensor, wiper delay control, heated washer nozzles. Remote central locking w/ luggage compartment release. Anti theft system including passenger compartment monitoring. Homelink door opener, cruise control. Automatically dimming interior and drivers side exterior mirrors with rain sensor.

Passive Safety Equipment

Fully galvanized high strength steel body w/ front & rear deformation zones. 3 point seat belts w/ pre-tensioners and force limiters. Seat belt height adjustment. 2 stage driver/passenger airbags. Porsche Side Impact Protection System (POSIP) consisting of side impact protection elements in each door, thorax side airbags integrated in seat backrests, head airbags located in door trim. Preparation for child seat anchorage (ISOFIX) on passenger side w/ switch for airbag deactivation.

Interior Equipment

Fully electric seats including lumbar support with memory function on driver side. Split folding rear seats. 3 spoke steering wheel w/ manual reach and height adjustment. Leather interior, decorative stitching in light contrast color. Interior trim in soft-paint in interior color. Air vents, dashboard trim, trim surround on gear selector in aluminum look finish. Various interior parts in Volcano gray. Roof liner in Alcantara. Automatic climate control with integrated carbon filter. Two cup holders in front. Door storage bins. Door entry guards with "Turbo" logotype. Illuminated driver and passenger vanity mirrors.

Porsche Cars North America – United States Order Guide – 2008 Model Year
Options, Prices, content, and availability are subject to change without notice.

PORSCHE®

Turbo Cabriolet

US \$136,500

Model Year 2008 Standard Equipment includes:

Engine

480 hp, 460 lb ft torque - 3.6 liter horizontally opposed 6 cylinder with aluminum alloy engine block & cylinder heads, rear mounted engine. Twin Turbochargers with VTG (variable turbine geometry), twin intercoolers. Dry sump lubrication system with 9 oil pumps, external oil tank. 4 overhead camshafts, 4 valves per cylinder with "VarioCam Plus" continuously variable inlet valve timing and lift. Cylinder specific knock control. Stainless steel exhaust system with twin brushed steel tail pipes integrated in the rear apron.

Power Transmission

6-speed Manual Transmission with double inertia flywheel. Hydraulic clutch actuation. All wheel drive with map controlled multi disc clutch center differential and PTM (Porsche Traction Management).

Chassis and Suspension

8.5"x19" forged Turbo wheels, 235/35 ZR19 high performance tires - front. 11"x19" forged Turbo wheels, 305/30 ZR19 high performance tires – rear, includes anti-theft device. TPMS – Tire Pressure Monitoring System. Puncture sealing compound and electric compressor. Power assisted steering with variable ratio. McPherson strut suspension with stabilizer bar – front. Multi link LSA (Light, Stable, Agile) suspension with stabilizer bar – rear. PASM – (Porsche Active Suspension Management) including 10mm lowering. PSM – (Porsche Stability Management), with ABS (Anti lock Braking System), ASR (Anti Slip Regulation), ABD (Automatic Brake Differential) and EDTC (Engine Drag Torque Control).

Braking System

13.8" vented and perforated rotors w/ 6 piston monobloc fixed alloy calipers – front, 4 piston monobloc fixed alloy calipers – rear. ABS 8.0 – Anti Lock Braking System, brake pad wear indicators, hand operated parking brake. Calipers painted in red.

Body

Two plus two Cabriolet, body shell hot dip galvanized on both sides. Luggage compartment lid and doors in Aluminum. Front apron with air intakes, front lights, indicators and fog lights. Rear side section with air intakes for charge-air intercoolers. Rear section with air outlets for charge-air intercoolers and high mounted and integrated tailpipes in chrome plated stainless steel. Side windows with water repellant coating. Heat able rear window. Automatically extendable rear spoiler. Chrome colored "Turbo" rear logotype. Metallic paint. Full underbody paneling. 17.7 gallon fuel tank.

Lighting System

Bi-Xenon lighting system with dynamic headlight leveling and headlight cleaning system. Welcome home function. Separate lights in front apron with LED-Indicator light and projector fog lights. Uniform lighting concept in white for entire interior, continuously variable. Foot well lighting.

Electrical Equipment

PCM (Porsche Communication Management) with 5.8" color display, 12 digit keypad, GPS navigation module for PCM with DVD drive in luggage compartment. AM/FM/CD radio with MP3-able CD drive for audio CD's. Bose Surround Sound System with 12 loudspeakers and 325 watt total power. On board computer with boost pressure gauge, digital continuous indication of total mileage, trip mileage, time, outside temp and speed. 5 dial type gauges indicating RPM's, speed, oil pressure, oil temperature, coolant temp and fuel level, w/ aluminum colored dials. Electronic oil level measurement with map compensation. Power windows with tip up/tip down and anti-jamming. Electrically operated rear side windows. Electrically operated, fully-automatic folding cabriolet top with heated glass rear window. Automatically dimming interior and drivers side exterior mirrors. Two speed wiper system with rain sensor, wiper delay control, heated washer nozzles. Remote central locking w/ luggage compartment release. Anti theft system including passenger compartment monitoring. Homelink door opener, cruise control. Automatically dimming interior and drivers side exterior mirrors with rain sensor.

Passive Safety Equipment

Fully galvanized high strength steel body w/ front & rear deformation zones. 3 point seat belts w/ pre-tensioners and force limiters. Seat belt height adjustment. 2 stage driver/passenger airbags. Porsche Side Impact Protection System (POSIP) consisting of side impact protection elements in each door, thorax side airbags integrated in seat backrests, head airbags located in door trim. Preparation for child seat anchorage (ISOFIX) on passenger side w/ switch for airbag deactivation. Automatically deployed roll-over protection system.

Interior Equipment

Fully electric seats including lumbar support with memory function on driver side. Split folding rear seats. 3 spoke steering wheel w/ manual reach and height adjustment. Leather interior, decorative stitching in light contrast color. Interior trim in soft-paint in interior color. Air vents, dashboard trim, trim surround on gear selector in aluminum look finish. Various interior parts in Volcano gray. Roof liner in black. Automatic climate control with integrated carbon filter. Two cup holders in front. Door storage bins. Door entry guards with "Turbo" logotype. Illuminated driver and passenger vanity mirrors.

Porsche Cars North America – United States Order Guide – 2008 Model Year
Options, Prices, content, and availability are subject to change without notice.

2.0b 2.4a 2.0a 2.4b 1.2a 1.0a 3.0b
 2.0e 2.0d 2.8b 2.8a 1.2c 1.1 1.0b

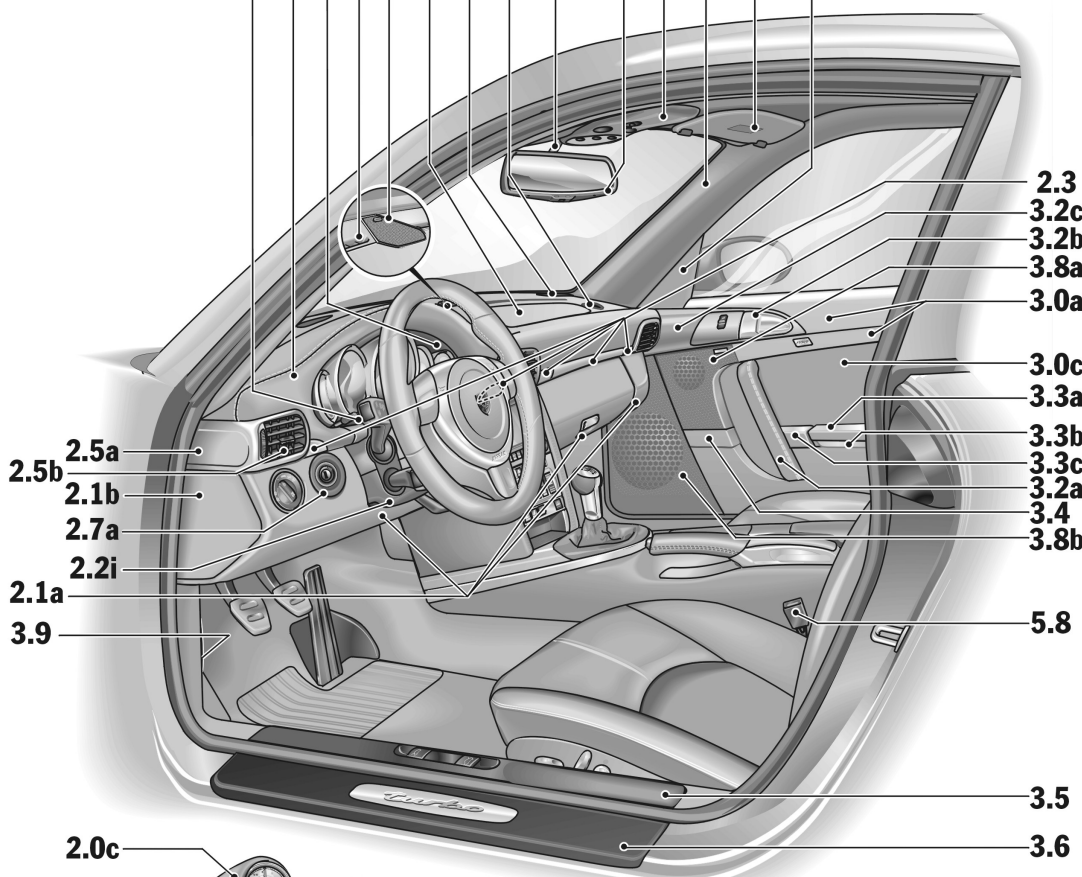
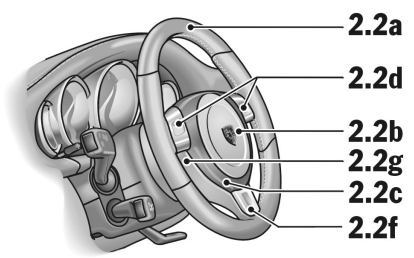
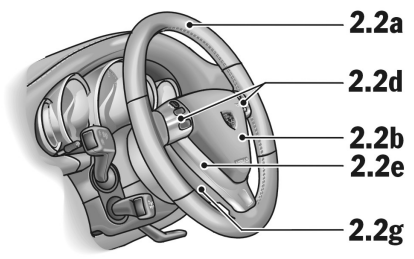

2.3
 3.2c
 3.2b
 3.8a
 3.0a
 3.0c
 3.3a
 3.3b
 3.3c
 3.2a
 3.4
 3.8b

2.5a
 2.1b
 2.7a
 2.2i
 2.1a
 3.9

5.8
 3.5
 3.6

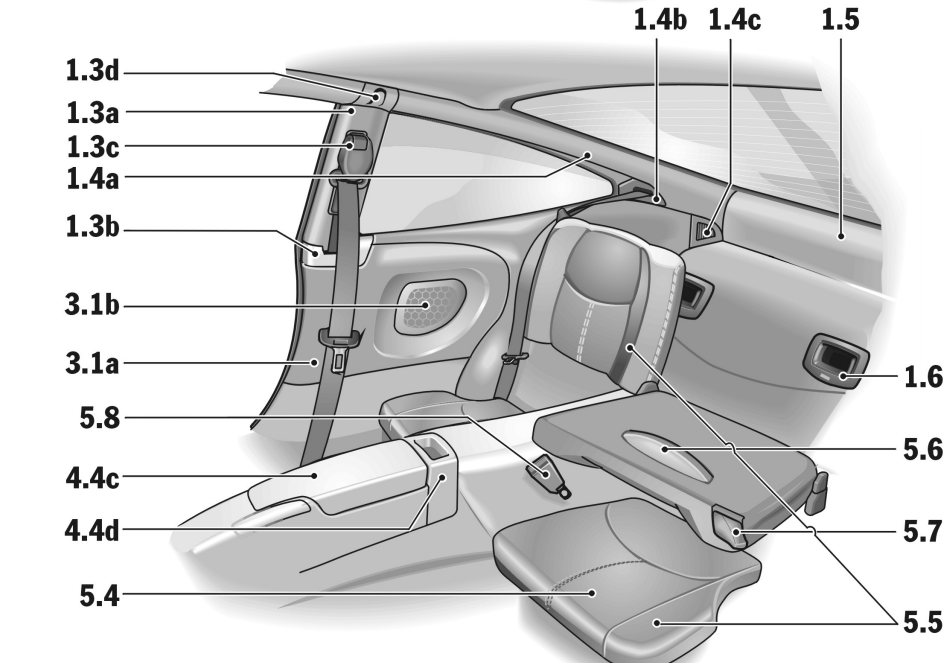
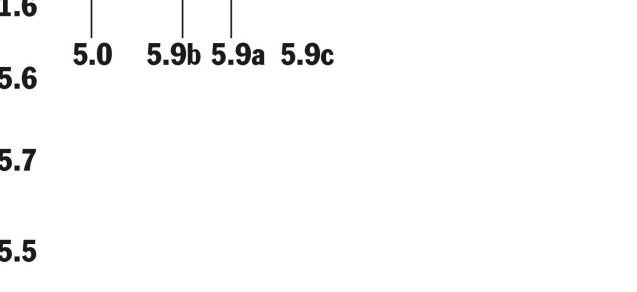
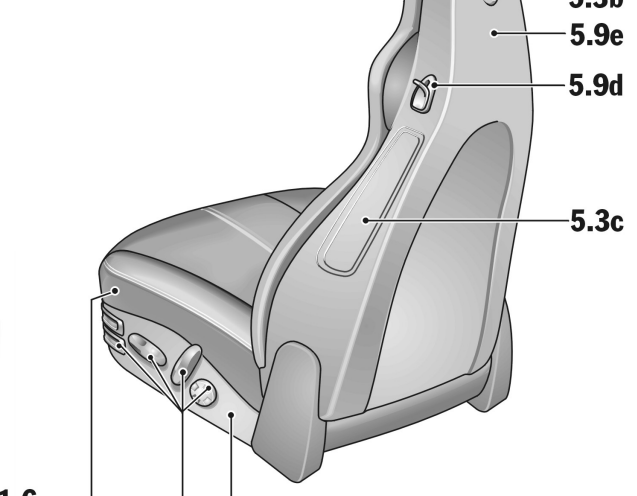
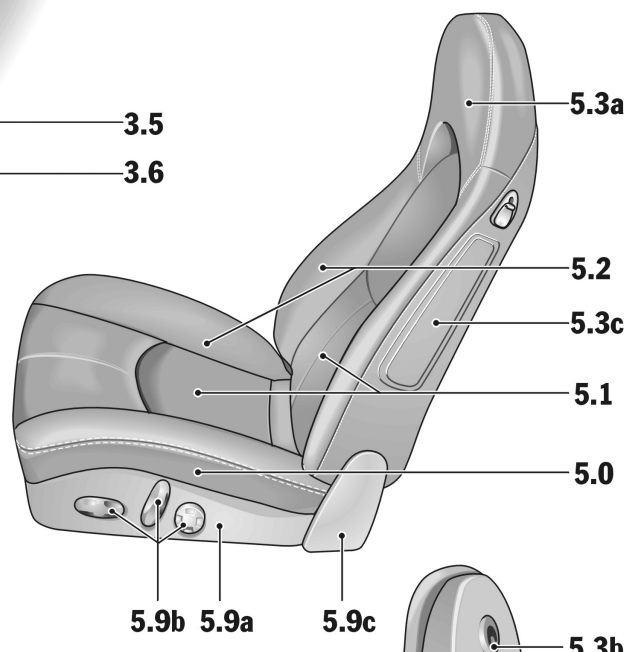
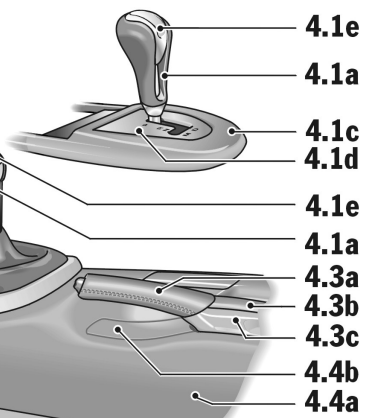
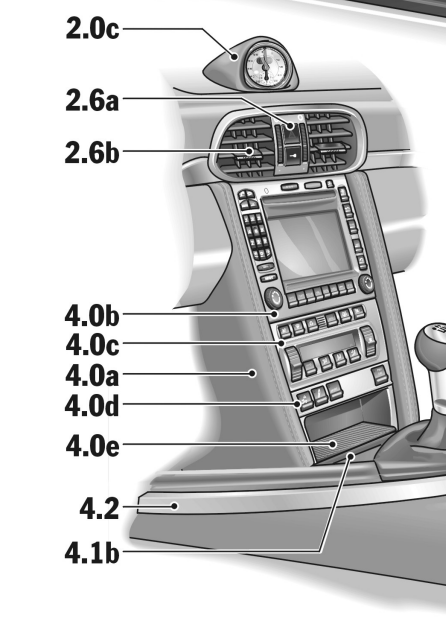

1.4b 1.4c 1.5

1.3d
 1.3a
 1.3c
 1.4a
 1.3b
 3.1b
 3.1a
 5.8
 4.4c
 4.4d
 5.4

1.6
 5.6
 5.7
 5.5

5.0 5.9b 5.9a 5.9c

Nr.	911 Turbo Descriptions	Nr.	911 Turbo Descriptions
1.0a	A-pillar/windscreen frame trim	4.0a	Centre console side trim, front
1.0b	Sun visors	4.0b	PCM trim
1.1	Interior light surround	4.0c	Climate control trim
1.2a	Rear view mirror frame	4.0d	Lower switch trim
1.2b	Rear view mirror casing	4.0e	Lower storage bin
1.2c	Rear view mirror mounting	4.1a	Gear lever or Tiptronic gear selector
1.3a	B-pillar trim	4.1b	Gear lever trim
1.3b	Belt outlets on B-pillars	4.1c	Tiptronic gear selector gate surround
1.3c	Belt height adjustment trim on B-pillars	4.1d	Tiptronic gear selector gate
1.3d	Clothes hook on B-pillars	4.1e	Decorative trim on shift pattern or release of Tiptronic gear selector
1.4a	C-pillar trim	4.2	Decorative trim on gear lever/selector
1.4b	Belt outlets on C-pillars	4.3a	Handbrake lever
1.4c	Rear air vent	4.3b	Handbrake finisher (upper section)
1.5	Rear panel trim	4.3c	Handbrake finisher (lower section)
1.6	BOSE subwoofer outlets	4.4a	Rear section of centre console incl. ashtray cover
2.0a	Switch panel (front part) incl. airbag cover	4.4b	Handbrake lever recess trim
2.0b	Switch panel (upper section) incl. instrument cover	4.4c	Lid of storage bin in rear section of centre console
2.0c	Timer cover	4.4d	Storage tray rear section of centre console
2.0d	Instrument surround	5.0	Seat base
2.0e	Instrument surround lower section	5.1	Seat centre, front
2.1a	Switch panel (lower section) incl. glove compartment, three-part	5.2	Lateral supports, front
2.1b	Switch panel end trim	5.3a	Integrated head restraints, front
2.2a	Steering wheel rim	5.3b	Clothes hook seat backrest
2.2b	Airbag module	5.3c	Thorax airbag cover
2.2c	Airbag module surround on three-spoke sports steering wheel	5.4	Seat centre, rear
2.2d	Tiptronic S switches (left/right) or spoke trim (left/right)	5.5	Lateral supports, rear
2.2e	"Y" trim on standard steering wheel	5.6	Luggage stop on rear seat backrests
2.2f	Lower spoke trim on three-spoke sports steering wheel	5.7	Release lever on rear seat backrests incl. base plate
2.2g	Steering wheel hub cover	5.8	Belt buckles (front/rear)
2.2h	Steering wheel adjustment collar	5.9a	Seat controls trim
2.2i	Steering column casing incl. hands-free microphone, three-part	5.9b	Seat controls
2.3	Trim strip switch panel incl. cupholder trim, five-part	5.9c	Hinge cover
2.4a	Defroster trim	5.9d	Release lever surround
2.4b	Defroster air vent	5.9e	Sports seat backrest
2.5a	Side air vent		
2.5b	Side air vent slats		
2.6a	Central air vent incl. switch trim		
2.6b	Central air vent slats		
2.7a	Ignition lock surround		
2.8a	Loudspeaker finishers (treble) on switch panel (left/right)		
2.8b	Loudspeaker finisher on switch panel (centre)		
3.0a	Door trim incl. Head-Airbag cover		
3.0b	Mirror attachment point finishers incl. mirror controls and base plate		
3.0c	Door panel		
3.1a	Side trim, rear seat area		
3.1b	Loudspeaker finishers at rear		
3.2a	Front of door handle		
3.2b	Door opener		
3.2c	Door opener trim		
3.3a	Lid of door storage bin		
3.3b	Door storage bin surround		
3.3c	Lid extension on door storage bin		
3.4	Door panel trim		
3.5	Inner sill finisher		
3.6	Door entry guard		
3.8a	Loudspeaker finishers (mid-tone) incl. seat memory trim (driver's side)		
3.8b	Loudspeaker finishers (bass)		
3.9	Fuse box trim		

Order Guide

Option	Description	Must Pick	Required	Conflict	Model	Price (USD)
Standard Paint						
A1	Black				Turbo Coupe	\$0
					Turbo Cabriolet	\$0
B4	Carrara White				Turbo Coupe	\$0
					Turbo Cabriolet	\$0
G1	Guards Red				Turbo Coupe	\$0
					Turbo Cabriolet	\$0
X4	Speed Yellow				Turbo Coupe	\$0
					Turbo Cabriolet	\$0
Optional Metallic Paint						
53	Forest Green Metallic				Turbo Coupe	\$0
					Turbo Cabriolet	\$0
56	Cobalt Blue Metallic				Turbo Coupe	\$0
					Turbo Cabriolet	\$0
9Q	Meteor Grey metallic				Turbo Coupe	\$0
					Turbo Cabriolet	\$0
9S	Macadamia Metallic				Turbo Coupe	\$0
					Turbo Cabriolet	\$0
E9	Midnight Blue Metallic				Turbo Coupe	\$0
					Turbo Cabriolet	\$0
L2	Ruby Red Metallic				Turbo Coupe	\$0
					Turbo Cabriolet	\$0
X1	Arctic Silver Metallic				Turbo Coupe	\$0
					Turbo Cabriolet	\$0
Z4	Basalt Black Metallic				Turbo Coupe	\$0
					Turbo Cabriolet	\$0

Option	Description	Must Pick	Required	Conflict	Model	Price (USD)
Special Paint						
59	Slate Grey Metallic				Turbo Coupe	\$2,450
					Turbo Cabriolet	\$2,450
7G	Dark Olive Metallic				Turbo Coupe	\$2,450
					Turbo Cabriolet	\$2,450
E7	Atlas Grey Metallic				Turbo Coupe	\$2,450
					Turbo Cabriolet	\$2,450
H1	Malachite Green Metallic				Turbo Coupe	\$2,450
					Turbo Cabriolet	\$2,450
U2	GT Silver Metallic				Turbo Coupe	\$2,450
					Turbo Cabriolet	\$2,450
Paint to Sample						
98	Non-Metallic Paint to Sample This option usually results in a production delay of 3 to 6 months. Not all color requests can be fulfilled and Porsche may require the customer or dealership to supply a paint sample or paint code in order to conduct feasibility testing. The deadline for submission of Model Year 2008 Paint to Sample orders will be approximately February 01, 2008.	24931	22291	789	Turbo Coupe	\$3,625
					Turbo Cabriolet	\$3,625
99	Metallic Paint to Sample This option usually results in a production delay of 3 to 6 months. Not all color requests can be fulfilled and Porsche may require the customer or dealership to supply a paint sample or paint code in order to conduct feasibility testing. The deadline for submission of Model Year 2008 Paint to Sample orders will be approximately February 01, 2008.	24931	22291	789	Turbo Coupe	\$3,625
					Turbo Cabriolet	\$3,625
Convertible Top Colors						
V3	Cabriolet roof in Stone Grey				Turbo Cabriolet	\$0
V4	Cabriolet roof in Metropol Blue				Turbo Cabriolet	\$0

Option	Description	Must Pick	Required	Conflict	Model	Price (USD)
V5	Cabriolet roof in Cocoa				Turbo Cabriolet	\$0
V9	Cabriolet roof in Black				Turbo Cabriolet	\$0
Leather for Sport Seats						
P77	Leather Sport Seats			P01 P03 982	Turbo Coupe	\$0
	Manual height and front/back adjustment. Power recline. Seatbacks in Volcano Grey.				Turbo Cabriolet	\$0
Full Leather						
AT	Black Full Leather				Turbo Coupe	\$0
					Turbo Cabriolet	\$0
DF	Stone Grey Full Leather				Turbo Coupe	\$0
					Turbo Cabriolet	\$0
FE	Sea Blue Full Leather				Turbo Coupe	\$0
					Turbo Cabriolet	\$0
TG	Sand Beige Full Leather				Turbo Coupe	\$0
					Turbo Cabriolet	\$0
970	Two-tone leather interior	BK BM BP		998	Turbo Coupe	\$0
					Turbo Cabriolet	\$0
Special Leather						
05	Dark Grey Natural Leather		998		Turbo Coupe	\$1,510
					Turbo Cabriolet	\$1,510
06	Brown Natural Leather		998	970	Turbo Coupe	\$1,510
					Turbo Cabriolet	\$1,510
07	Carrera Red Natural Leather		998	970	Turbo Coupe	\$1,510
					Turbo Cabriolet	\$1,510

Option	Description	Must Pick	Required	Conflict	Model	Price (USD)
BK	Black/Stone Grey Interior Black Leather: Windshield pillar and frame, B and C pillars, upper dash and instrument hump, steering wheel rim, top of door molding. Stone Grey Leather: Bottom Lower dash, side covers of center console, storage lid of center console, gearshift and handbreak lever, door handle, door pocket cover and frame, door center panel, rear side covering. Stone Grey Soft Pain: Dashboard end cover, rear center console, including ashtray lid handle recess cover, handbreak lever, storage box in rear center console, cover dashboard/frame Tiptronic S shift gate, loudspeaker cover, front loudspeaker cover, door pocket frame. Seats in Black leather. Sunvisors in Black. Carpeting in Stone Grey.		970		Turbo Coupe	\$430
					Turbo Cabriolet	\$430
BM	Black/Sand Beige Interior Black Leather: Windshield pillar and frame, B and C pillars, upper dash and instrument hump, steering wheel rim, top of door molding. Sand Beige Leather: Lower dash, side covers of center console, storage lid of center console, gearshift and handbreak lever, door handle, door pocket cover and frame, door center panel, rear side covering. Sand Beige Soft Paint: Dashboard end cover, rear center console, including ashtray lid handle recess cover, handbreak lever, storage box in rear center console, cover of dashboard/frame Tiptronic S shift gate, loudspeaker cover, cover of front loudspeaker, door pocket frame. Seats in Black leather. Sunvisors in Black. Carpeting in Sand Beige.		970		Turbo Coupe	\$430
					Turbo Cabriolet	\$430
BP	Black/Terracotta Interior Black Leather: Windshield pillar and frame, B and C pillars, upper dash and instrument hump, steering wheel rim, top of door molding. Terracotta Leather: Bottom dash, side covers of center console, storage lid of center console, gearshift and handbreak lever, door handle, door pocket cover and frame, door center panel, rear side covering. Soft Paint Terracotta: Dashboard end cover, rear center console, including ashtray lid handle recess cover, handbreak lever, storage box in rear center console, cover dashboard/frame Tiptronic S shift gate, loudspeaker cover, cover of front loudspeaker, door pocket frame. Seats in Black leather. Sunvisors in Black. Carpeting in Terracotta.		970		Turbo Coupe	\$430
					Turbo Cabriolet	\$430

Option	Description	Must Pick	Required	Conflict	Model	Price (USD)
MB	Special Leather Terracotta				Turbo Coupe	\$430
					Turbo Cabriolet	\$430
RA	Special Leather Cocoa				Turbo Coupe	\$430
					Turbo Cabriolet	\$430

Leather to Sample

99	Leather Interior to Sample This option usually results in a production delay of 3 to 6 months. An interior sketch is required. Not all leather requests can be fulfilled and Porsche may require the customer or dealership to supply a leather sample or previous interior code in order to conduct feasibility testing. The deadline for submission of Model Year 2008 Leather to Sample orders will be approximately February 01, 2008. Note: Loudspeaker grills (door and dash), steering wheel, and airbag cover in black. Steering wheel rim in black unless Exclusive options are ordered.	24941	00341		Turbo Coupe	\$1,750
		24961			Turbo Cabriolet	\$1,750

Floormats

810	Floor Mats in Interior Color			CFX	Turbo Coupe	\$140
					Turbo Cabriolet	\$140
CFX	Floor Mats With Colored Trim Floormats in interior color with trim in choice of Black, Sea Blue, Stone Grey, Sand Beige, Palm Green, Cocoa, Natural Brown, Speed Yellow, and Guards Red.			CJX 810	Turbo Coupe	\$510
					Turbo Cabriolet	\$510

Seats

342	Heated Seats Multi-stage heating system for front seats.				Turbo Coupe	\$500
					Turbo Cabriolet	\$500
982	Supple Leather Front and Rear Soft ruffled leather on front and rear seat centers	AT BK BM BP DF		P01 P77	Turbo Coupe	\$395
		FE MB RA TG 05 06 07 99			Turbo Cabriolet	\$395
P01	Adaptive Sports Seats Sport seats with electric adjustment for all seat functions, adjustable side bolsters, memory function for seat, and mirrors. Includes lumbar adjustment on driver side. Seatbacks in Volcano Grey.			P03 P77 982	Turbo Coupe	\$1,145
					Turbo Cabriolet	\$1,145

Option	Description	Must Pick	Required	Conflict	Model	Price (USD)
XSC	Porsche Crest in Headrests Head restraints on front seats embossed with Porsche crest.				Turbo Coupe	\$270
					Turbo Cabriolet	\$270
Audio & Communications						
461	Rod antenna				Turbo Coupe	\$0
					Turbo Cabriolet	\$0
635	ParkAssist Parking aid with four distance sensors integrated discreetly at rear of car.				Turbo Coupe	\$530
					Turbo Cabriolet	\$530
640	Sport Chrono Package Turbo Analog and digital chronometer, sport button in the center console and display in the PCM, also adds ability to adjust lighting, wipers, AC and door locking to suit personal preference. The Sport Chrono Package Turbo also provides a temporary overboost of approx. 0.2 bar increasing the maximum torque significantly from approx. 460 lb.-ft. to a maximum of 505 lb.-ft. between 2,100 rpm and 4,000 rpm. The result - markedly improved acceleration and elasticity especially in the mid rev range.				Turbo Coupe	\$1,920
					Turbo Cabriolet	\$1,920
641	Electronic Logbook Enables automatic acquisition of mileage, driving distance, date, time and address of starting point and destination at every trip including PC- software for data download and evaluation.				Turbo Coupe	\$650
					Turbo Cabriolet	\$650
666	Telephone module Three-band telephone for GSM 900, 1800 and 1900 networks, small SIM card, 12 digit keypad, basic phone functions can be activated via control stalks on steering column and simultaneously displayed in the instrument cluster, hands-free facility, seperate operation of SMS and voice functions via main menu.				Turbo Coupe	\$960
					Turbo Cabriolet	\$960
668	Handset for Telephone Module Passive handset for telephone module. Handset does not have dialing capability.		666		Turbo Coupe	\$260
					Turbo Cabriolet	\$260
692	Six-disc CD autochanger Holds up to 6 CDs, features digital anti-shock memory (no jumping of music tracks) and MOST connection.				Turbo Coupe	\$650
					Turbo Cabriolet	\$650

Option	Description	Must Pick	Required	Conflict	Model	Price (USD)
Technical						
220	Axle-Differential Lock Rear			249	Turbo Coupe Turbo Cabriolet	\$950 \$950
249	Tiptronic S 5-speed automatic transmission with gearshift controls on steering wheel.			ECA XCZ 220	Turbo Coupe Turbo Cabriolet	\$3,420 \$3,420
425	Rear wiper				Turbo Coupe	\$0
450	Porsche Ceramic Composite Brake (PCCB) Porsche Ceramic Composite Brake (PCCB) system. Carbon-fiber reinforced ceramic brake discs, internally ventilated and perforated, and yellow painted brake calipers.			447	Turbo Coupe Turbo Cabriolet	\$8,840 \$8,840
509	Fire extinguisher DIN EN3-compliant powder-based system containing 1 kg of extinguishant. Stows neatly beneath driver's seat.				Turbo Coupe Turbo Cabriolet	\$140 \$140
549	Roof transport system Coupe 165 lb. payload, can be used with all Porsche load carrier accessories.				Turbo Coupe	\$400
550	Hard Top Hardtop in exterior color with heated rear window.				Turbo Cabriolet	\$3,490
XCZ	Sport shifter Reduces shift travel for highly efficient shifting. Note: only in conjunction with manual transmission.			249	Turbo Coupe Turbo Cabriolet	\$765 \$765
Wheels						
XD9	Rims and Caps - Exterior Color Painted wheels and wheel centers with full-color Porsche crest.		Z4 A1 G1 X4 B4		Turbo Coupe Turbo Cabriolet	\$1,290 \$1,290
Interior Options						
CEE	Rear footwell lighting Additional lights in rear footwell (left/right)				Turbo Coupe Turbo Cabriolet	\$415 \$415

Option	Description	Must Pick	Required	Conflict	Model	Price (USD)
Interior Cosmetic						
X70	Door Entry Guards in Stainless Steel Door entry guards in stainless steel with Carrera logo.			CUA CXB CXC	Turbo Coupe	\$415
				CXD CXE X69	Turbo Cabriolet	\$415
XFD	Instrument dials in Sand Beige Paint finish in Sand Beige.			XFH XFJ	Turbo Coupe	\$860
					Turbo Cabriolet	\$860
XFH	Instrument dials in Speed Yellow Paint finish in Speed Yellow.			XFD XFJ	Turbo Coupe	\$860
					Turbo Cabriolet	\$860
XFJ	Instrument dials in Carrara White Paint finish in Carrara White.			XFD XFH	Turbo Coupe	\$860
					Turbo Cabriolet	\$860
XSH	Seat belts in Silver Full set of belts for front and rear.			XSX XSY	Turbo Coupe	\$540
					Turbo Cabriolet	\$540
XSX	Seat belts in Guards Red Full set of belts for front and rear.			XSH XSY	Turbo Coupe	\$540
					Turbo Cabriolet	\$540
XSY	Seat belts in Speed Yellow Full set of belts for front and rear.			XSH XSX	Turbo Coupe	\$540
					Turbo Cabriolet	\$540
XXZ	Footrest in Aluminum Driver's side foot rest in aluminum and rubber.				Turbo Coupe	\$250
					Turbo Cabriolet	\$250
Interior Options in Leather						
431	Three-Spoke Multi-function Steering Wheel Smooth leather finish in interior color on steering wheel rim (with cross-stitched seam) and airbag module.			XPA XPV 451 452	Turbo Coupe	\$250
				453 459	Turbo Cabriolet	\$250
459	Three-Spoke Steering Wheel in Smooth Leather Smooth leather finish in interior colour on steering wheel rim (with cross-stitched seam) and airbag module.			XPA XPV 431 451	Turbo Coupe	\$0
				452 453	Turbo Cabriolet	\$0
EAA	Leather Package Switch Panel Smooth leather finish in interior color: side air vents, side air vent slats, central air vent including switch trim, central air vent slats, loudspeaker finisher on switch panel, defroster trim, trim strip switch panel including cupholder trim.			EAB EAC EAD EAE	Turbo Coupe	\$2,050
				801 802 803	Turbo Cabriolet	\$2,050

Option	Description	Must Pick	Required	Conflict	Model	Price (USD)
XEA	PCM Handset Leather PCM Handset in smooth leather finish in interior color, including support (three-part).		668		Turbo Coupe	\$415
					Turbo Cabriolet	\$415
XMA	Rooflining leather Rooflining in leather in interior color.				Turbo Coupe	\$1,180
XMP	Sun visors in leather Sun visors and vanity mirror covers in leather in interior color.				Turbo Coupe	\$560
					Turbo Cabriolet	\$560
XMZ	Rear Center Console in Leather Smooth leather finish in interior color: rear section of center console incl. ashtray cover, storage tray rear section of center console, handbrake lever recess trim.			XCK XJT XJU XME XMJ	Turbo Coupe	\$1,260
					Turbo Cabriolet	\$1,260
XNG	Instrument Surround in Leather Instrument surround in leather finish in interior color.			EAE XCL	Turbo Coupe	\$260
					Turbo Cabriolet	\$260
XNS	Steering Column in Leather Steering column casing (three-part) in smooth leather finish in interior color.				Turbo Coupe	\$420
					Turbo Cabriolet	\$420
XPA	Thicker Steering Wheel in Leather Thicker 3-spoke sports steering wheel in smooth leather in interior color.			XPV 431 451 452 453 459	Turbo Coupe	\$310
					Turbo Cabriolet	\$310
XSB	Sport Seat Backs in Leather Rear of backrests in smooth leather in interior color. Note: available in color to sample as Exclusive Special Order.	P01 P77		XCG XSA	Turbo Coupe	\$1,610
					Turbo Cabriolet	\$1,610
XTG	Inner sill finishers leather Inner sill finishers in leather in interior color.				Turbo Coupe	\$585
					Turbo Cabriolet	\$585
XTV	Door Finishers in Leather Door opener trim in leather finish in interior color.			XTL XTT XTU XTW	Turbo Coupe	\$360
					Turbo Cabriolet	\$360
XZD	Dome Lamp Cover - Leather Smooth leather finish in interior color: interior light cover.				Turbo Coupe	\$335

Option	Description	Must Pick	Required	Conflict	Model	Price (USD)
Custom Tailoring and Deviations - Leather						
CDT	Seat Belt Buckles in Leather Seat belt buckles featuring smooth leather finish in interior color, including decorative stitching where appropriate.				Turbo Coupe Turbo Cabriolet	\$760 \$760
CDU	Belt Outlet on B Pillar in Leather Smooth leather finish in interior color on seat belt outlet on B-pillars.			CCW CDR CFE CFS CJJ CMR DAB	Turbo Coupe Turbo Cabriolet	\$215 \$215
CDW	"Y" Trim Steering Wheel in Leather Smooth leather finish in interior color on "Y" trim of steering wheel.	431 451 452 453 459 XPV		CDD XPA	Turbo Coupe Turbo Cabriolet	\$270 \$270
CDZ	Gear Lever Trim Leather Gear lever trim smooth leather finish in interior color. Includes decorative stitching where appropriate.			DAW DAX 249	Turbo Coupe Turbo Cabriolet	\$250 \$250
CFA	Tiptronic Gate in Leather Leather finish in interior color on Tiptronic gear selector surround, including decorative stitching where appropriate.		249	DAV	Turbo Coupe Turbo Cabriolet	\$305 \$305
CFP	Tiptronic S Handbrake Lever in Aluminum and Leather Inlay in handbrake lever with Porsche logo in aluminum. Handbrake lever and handbrake finisher (upper section) in smooth leather finish in interior color. Handbrake finisher (lower section) in aluminum look paint finish.		249	DAD DAT DAU DAV DAW DAX ECA 801 802 803	Turbo Coupe Turbo Cabriolet	\$775 \$775
CNA	Defroster Trim in Leather Smooth leather finish in interior color on defroster trim and loudspeaker finisher on switch panel.			CDG CMG EAA EAB EAC EAD EAE	Turbo Coupe Turbo Cabriolet	\$535 \$535
CNB	Defroster Air Vents in Leather Smooth leather finish in interior color on defroster air vents. Soft touch paint finish in interior color on defroster air vent slats.				Turbo Coupe Turbo Cabriolet	\$365 \$365
CPA	Thicker Multi-function Steering Wheel in Leather Thicker three-spoke steering wheel rim with cross-stitched seam.	431 459		CLA XPA XPV 451 452 453	Turbo Coupe Turbo Cabriolet	\$930 \$930
CPT	Storage Lid Bin with Porsche Crest Smooth leather finish in interior color on lid of storage bin in rear section of center console with Porsche crest. Includes decorative stitching where appropriate.			CLG CUV	Turbo Coupe Turbo Cabriolet	\$295 \$295

Option	Description	Must Pick	Required	Conflict	Model	Price (USD)
CPU	Key Pouch in Interior Color Leather In smooth leather in interior color with embossed Porsche crest and decorative seam.				Turbo Coupe	\$95
					Turbo Cabriolet	\$95
CUJ	Fuse Box Trim Leather Smooth leather finish in interior color on fuse box cover. Includes decorative stitching where appropriate.				Turbo Coupe	\$145
					Turbo Cabriolet	\$145
CUR	PCM Package in Leather Smooth leather finish in interior color on PCM trim, climate control trim, lower switch trim, lower storage bin.			CCP CMF CUF	Turbo Coupe	\$2,070
					Turbo Cabriolet	\$2,070
CUV	Storage Compartment Lid with Model Logo Smooth leather finish in interior color on lid of storage bin in rear section of center console with Carrera logo. Includes decorative stitching where appropriate.			CLG CPT	Turbo Coupe	\$295
					Turbo Cabriolet	\$295
CUX	Release Lever for Rear Seats in Leather Smooth leather finish in interior color on rear seat backrest release lever, including baseplate. Includes decorative stitching where appropriate.			DAC	Turbo Coupe	\$310
					Turbo Cabriolet	\$310
CVD	Luggage Stop on Rear Seat Backrest in Leather Luggage stop on rear seat backrest with smooth leather finish in interior color including decorative stitching.			DAC	Turbo Coupe	\$475
CVP	Trim Strip Leather Smooth leather finish in interior color on trim strip switch panel including cupholder trim.			CDM CLE CMM EAA 801 802 803	Turbo Coupe	\$605
					Turbo Cabriolet	\$605
CVT	Door and Rear Speakers in Leather Smooth leather finish in interior color including decorative stitching where appropriate: door panel trim, loudspeaker finishers (mid-tone), loudspeaker finishers (bass). Soft touch paint finish in interior color: loudspeaker grilles. In black plastic: seat memory trim (driver's side).				Turbo Coupe	\$2,570
					Turbo Cabriolet	\$2,570
CVW	Rear View Mirror Leather Smooth leather finish in interior color: rear view mirror frame, rear view mirror casing, rear view mirror mounting.				Turbo Coupe	\$475
					Turbo Cabriolet	\$475

Option	Description	Must Pick	Required	Conflict	Model	Price (USD)
CVY	Clothes Hook on Seat Backrest in Leather Clothes hook on seat backrest in smooth leather finish in interior color. Includes decorative stitching where appropriate.			DAB P03	Turbo Coupe	\$240
					Turbo Cabriolet	\$240
CVZ	Bose Subwoofer Outlets in Leather Smooth leather finish in interior color				Turbo Coupe	\$225
CZD	Interior Light Cover in Leather Interior light surround smooth leather finish in interior color. Includes decorative stitching where appropriate.				Turbo Cabriolet	\$430
DAA	Interior Package A Pillar in Leather Smooth leather finish in interior color on switch panel end trim, ignition lock surround, and mirror attachment point finishers including mirror controls and base plate. Includes decorative stitching where appropriate.				Turbo Coupe	\$740
					Turbo Cabriolet	\$740
DAB	Interior Package B Pillar in Leather Leather finish interior color on belt outlet on B pillar, belt height adjustment trim on B pillars, clothes hook on B pillars, and clothes hook on seat backrest. Includes decorative stitching where appropriate.			CDU CVY P03	Turbo Coupe	\$955
DAC	Interior Package C Pillar in Leather Leather finish in interior color on belt outlet on C pillars, rear air vent, luggage stop on rear backrests, and release lever on rear seat backrest, including base plate. Includes decorative stitching where appropriate.			CUX CVD	Turbo Coupe	\$1,030
DAD	Gear Lever/Handbrake in Aluminum and Leather Gear lever (partially) and inlay in handbrake lever with Porsche logo in Aluminum. Smooth leather finish in interior color on handbrake lever and handbrake finisher (upper section). Aluminum look paint finish on handbrake finisher. Note: with leather in color to sample or deviating stitching, use option DAW.			DAT DAW DAX ECA 249 801 802 803	Turbo Coupe	\$1,555
					Turbo Cabriolet	\$1,555
DAW	Gear Lever and Handbrake Lever Aluminum/Leather Gear lever and handbrake in leather and aluminum. Valid only with interior to sample or when ordering deviating stitching.			CDZ DAD DAT DAX ECA 249 801 802 803	Turbo Coupe	\$2,130
					Turbo Cabriolet	\$2,130

Option	Description	Must Pick	Required	Conflict	Model	Price (USD)
Interior Options in Aluminum Look						
EAE	Aluminum Look Package Switch Panel Aluminum Look paint finish on side air vents, central air vent including switch trim, and instrument surround. Smooth leather finish in interior color on side air vent slats, central air vent slats, loudspeaker finisher on switch panel, and defroster trim.			EAA EAB EAC EAD XNG	Turbo Coupe Turbo Cabriolet	\$1,550 \$1,550
ECA	Gear Lever and Handbrake Lever in Aluminum Look Gear lever and handbrake lever (partially) in Aluminum. Smooth leather finish in interior color on inlays in gear lever and handbrake finisher (upper section). Aluminum Look paint finish on handbrake finisher (lower section).			DAD 249 801 802 803	Turbo Coupe Turbo Cabriolet	\$1,035 \$1,035
XCG	Seat Backs in Aluminum Look Rear of backrests with Aluminum Look paint finish.	P01 P77		XSA XSB	Turbo Coupe Turbo Cabriolet	\$1,495 \$1,495
XCK	Rear Center Console in Aluminum Look Rear section of center console including ashtray cover storage tray rear section of center console in aluminum look painted finish. Handbrake lever recess trim in leather finish in interior color.			XJT XJU XME XMJ XMZ	Turbo Coupe Turbo Cabriolet	\$730 \$730
XCL	Instrument Surround in Aluminum Look			XNG	Turbo Coupe Turbo Cabriolet	\$360 \$360
XPV	Aluminum Look Multi-function Steering Wheel Aluminum Look paint finish with smooth leather in interior color on steering wheel rim (with cross stitched seam). Smooth leather finish in interior color on airbag module and steering wheel hub cover.			XPA 431 451 452 453 459	Turbo Coupe Turbo Cabriolet	\$620 \$620
XTW	Door Finishers Aluminum Look Aluminum Look paint finish on front of door handle, lid of door storage bin including lid extension, and door opener trim.			XTL XTT XTU XTV	Turbo Coupe Turbo Cabriolet	\$1,550 \$1,550
Custom Tailoring and Deviations - Aluminum Look						
CCP	PCM Package in Aluminum Look Aluminum Look paint finish: PCM trim, climate control trim, lower switch trim, lower storage bin.			CMF CUF CUR	Turbo Coupe Turbo Cabriolet	\$2,070 \$2,070

Option	Description	Must Pick	Required	Conflict	Model	Price (USD)
CCR	PCM Handset in Aluminum Look Aluminum look finish on upper section. Leather finish interior color on lower section, including support (three part).		668	CED CER CFC	Turbo Coupe	\$535
				CFH CML XEA	Turbo Cabriolet	\$535
CCW	Belt Outlet B-pillars in Aluminum Look Aluminum Look paint finish on belt outlet on B-pillars (left/right).			CDR CDU CFE	Turbo Coupe	\$180
				CFS CJJ CMR DAB	Turbo Cabriolet	\$180
CDA	Air Vent Slats in Aluminum Look Aluminum look paint finish on side air vent slats and central air vent slats. Smooth leather finish in interior color on side air vents, central air vent including switch trim.			CDG CDN CMG	Turbo Coupe	\$940
				CMN EAA EAB	Turbo Cabriolet	\$940
				EAC EAD EAE		
CDD	"Y" Trim Steering Wheel in Aluminum Look	431 451 452		CDW XPA	Turbo Coupe	\$270
		453 459 XPV			Turbo Cabriolet	\$270
CNC	Front Air Intakes in Aluminum Look			CNF DAJ	Turbo Coupe	\$1,000
						Turbo Cabriolet
CNW	Wing Mirror in Aluminum Look Aluminum Look paint finish (opaque) on wing mirror (lower part of shell).				Turbo Coupe	\$550
						Turbo Cabriolet
Interior Options in Carbon						
453	Carbon Multi-function Steering Wheel 3-spoke multi-function steering wheel in carbon. Rim in smooth leather with carbon inlay, airbag module in smooth leather.			XPA XPV 431 451	Turbo Coupe	\$620
				452 459	Turbo Cabriolet	\$620
803	Carbon Package Carbon fiber finish: trim strip switch panel incl. cupholder trim, five part lever or Tiptronic selector, handbreak lever.			EAA ECA 801 802	Turbo Coupe	\$890
						Turbo Cabriolet
EAD	Carbon Package Switch Panel Carbon finish: inlay in defroster trim, side air vents, central air vent. Smooth leather finish in interior color: side air vent slats, central air vent slats including switch trim, loudspeaker finisher on switch panel, defroster trim.			EAA EAB EAC EAE	Turbo Coupe	\$2,700
						Turbo Cabriolet
X69	Door Entry Guards in Carbon Door entry guards in carbon with Turbo logo.			CUA CXB CXC	Turbo Coupe	\$780
				CXD CXE X70	Turbo Cabriolet	\$780

Option	Description	Must Pick	Required	Conflict	Model	Price (USD)
XMJ	Rear Center Console in Carbon Rear section of center console including ashtray cover, storage tray rear section of center console in carbon finish. Handbrake lever recess trim in leather finish in interior color.			XCK XJT XJU XME	Turbo Coupe	\$1,625
				XMZ	Turbo Cabriolet	\$1,625
XTL	Door Finisher in Carbon Carbon finish: front of door handle, lid of door storage bin incl. lid extension on door storage bin, door opener trim.			XTT XTU XTV XTW	Turbo Coupe	\$2,700
					Turbo Cabriolet	\$2,700
Custom Tailoring and Deviations - Carbon						
CED	PCM Handset in Carbon Carbon finish on upper section. Smooth leather finish in interior color on: lower section including support (three-part).		668	CCR CER CFC	Turbo Coupe	\$820
				CFE CFH CFS	Turbo Cabriolet	\$820
				CML XEA		
CJJ	Belt Outlets on B Pillars in Carbon			CCW CDR CDU	Turbo Coupe	\$450
				CFC CFE CFH CFS	Turbo Cabriolet	\$450
				CMR		
CXD	Door Entry Guards in Carbon, Illuminated Door entry guards in carbon with Turbo logo, illuminated in white.			CFC CFE CFH CFS	Turbo Coupe	\$1,280
				CUA CXB CXC	Turbo Cabriolet	\$1,280
				CXE X69 X70		
Customer Tailoring and Deviations - Alcantara						
CLA	Steering Wheel in Alcantara Thicker steering wheel rim in Alcantara black with cross-stitched seam. Airbag module is not in Alcantara.			CPA XPA XPV 451	Turbo Coupe	\$1,105
				452 453	Turbo Cabriolet	\$1,105
CLE	Trim Strip Switch Panel in Alcantara Trim strip in Alcantara including cup holder.			CDM CMM CVP	Turbo Coupe	\$775
				801 802 803	Turbo Cabriolet	\$775
CLG	Lid of Storage Bin in Alcantara with Logo Alcantara finish in black on lid of storage bin in rear center console with Porsche logo. Includes decorative stitching where appropriate.			CPT CUV	Turbo Coupe	\$490
					Turbo Cabriolet	\$490
DAT	Gear and Handbrake Lever in Alcantara Alcantara finish in black with decorative stitching where appropriate on gear lever, handbrake lever, and handbrake finisher. Decorative trim on shift pattern including middle shift pattern and inlay in handbrake lever with Porsche Logo in aluminum. Aluminum look paint finish on handbrake finisher.			DAD DAW DAX	Turbo Coupe	\$1,880
				ECA 249 801	Turbo Cabriolet	\$1,880
				802 803		

Option	Description	Must Pick	Required	Conflict	Model	Price (USD)
DAU	Tiptronic Gear Selector & Handbrake Lever in Alcantara Alcantara finish in black on Tiptronic gear selector handbrake lever and handbrake finisher. In aluminum: decorative trim on shift pattern including middle shift pattern, inlay in handbrake lever with Porsche Logo. Includes decorative stitching where appropriate.		249	CFP DAV 801 802 803	Turbo Coupe Turbo Cabriolet	\$1,880 \$1,880
Interior Options in Light Wood						
452	Sycamore Multi-function Steering Wheel Three-spoke multi-function steering wheel in light Sycamore. Rim in smooth leather with wood inlay. Airbag module in smooth leather.			XPA XPV 431 451 453 459	Turbo Coupe Turbo Cabriolet	\$620 \$620
802	Wood Package Sycamore Light sycamore finish: trim strip switch panel including cupholder trim, five-part gear lever or Tiptronic S selector, and handbrake lever.			EAA ECA 801 803	Turbo Coupe Turbo Cabriolet	\$890 \$890
EAC	Sycamore Package Switch Panel Light Sycamore finish (matt silk finish): inlay in defroster trim, side air vents, central air vent. Smooth leather finish in interior color: side air vent slats, central air vent slats including switch trim, loudspeaker finisher on switch panel, defroster trim.			EAA EAB EAD EAE 801 803	Turbo Coupe Turbo Cabriolet	\$2,700 \$2,700
XJU	Rear Center Console Sycamore Light Sycamore finish (matte silk finish) on rear section of center console, including ashtray cover, and storage tray on rear section of center console. Smooth leather finish in interior color on handbrake lever recess trim.			XCK XJT XME XMJ XMZ	Turbo Coupe Turbo Cabriolet	\$1,625 \$1,625
XTU	Door Finishers Sycamore Light sycamore finish: front of door handle, lid of door storage bin incl. lid extension on door storage bin, door opener trim.			XTL XTT XTV XTW	Turbo Coupe Turbo Cabriolet	\$2,700 \$2,700
Interior Options in Dark Wood						
451	Makassar Multi-function Steering Wheel Three-spoke multi-function steering wheel in dark Makassar. Rim in smooth leather with wood inlay. Airbag module in smooth leather.			XPA XPV 431 452 453 459	Turbo Coupe Turbo Cabriolet	\$620 \$620

Option	Description	Must Pick	Required	Conflict	Model	Price (USD)
801	Wood Package Makassar Dark Makassar finish: trim strip switch panel including cupholder trim, five-part gear lever or Tiptronic S selector, and handbrake lever.			EAA ECA 802 803	Turbo Coupe	\$890
					Turbo Cabriolet	\$890
EAB	Makassar Package Switch Panel Dark Makassar finish (matt silk finish): inlay in defroster trim, side air vents, central air vent. Smooth leather finish in interior color: side air vent slats, central air vent slats including switch trim, loudspeaker finisher on switch panel, defroster trim.			EAA EAC EAD EAE	Turbo Coupe	\$2,700
					Turbo Cabriolet	\$2,700
XJT	Rear Center Console Makassar Dark makassar finish on rear section of center console, including ashtray cover and storage tray on rear section of center console. Leather finish in interior color on handbrake lever recess trim.			XCK XJU XME XMJ XMZ	Turbo Coupe	\$1,625
					Turbo Cabriolet	\$1,625
XTT	Door Finishers Makassar, Dark Dark Makassar finish: front of door handle, lid of door storage bin incl. lid extension on door storage bin, door opener trim.			XTL XTU XTV XTW	Turbo Coupe	\$2,700
					Turbo Cabriolet	\$2,700
Custom Tailoring and Deviations - Wood						
CFC	PCM Handset in Sycamore Light Sycamore finish (matte silk) on upper section. Smooth leather finish in interior color on lower section including support (three-part).	668		CCR CED CER CFH CFS CJJ CML CXD CXE XEA	Turbo Coupe	\$820
					Turbo Cabriolet	\$820
CFE	Belt Outlets on B Pillars in Sycamore			CCW CDR CDU CED CFH CFS CJJ CMR CXD CXE	Turbo Coupe	\$450
					Turbo Cabriolet	\$450
CFH	PCM Handset in Makassar Dark Makassar finish (matte silk) on upper section. Smooth leather finish in interior color on lower section including support (three-part).	668		CCR CED CER CFC CFE CJJ CML CXD CXE XEA	Turbo Coupe	\$820
					Turbo Cabriolet	\$820
CFS	Belt Outlets on B Pillars in Makassar			CCW CDR CDU CED CFC CFE CJJ CMR CXD CXE	Turbo Coupe	\$450
					Turbo Cabriolet	\$450

Option	Description	Must Pick	Required	Conflict	Model	Price (USD)
Interior Options in Exterior Color						
XME	Rear Center Console in Exterior Color Paint finish in exterior color on rear section of center console, including ashtray cover and storage tray rear on section of center console. Leather finish in interior color on handbrake lever recess trim.			XCK XJT XJU XMJ XMZ	Turbo Coupe Turbo Cabriolet	\$730 \$730
XSA	Sport Seat Backs Painted in Exterior Color	P01 P77		98 99 XCG XSB 789	Turbo Coupe Turbo Cabriolet	\$1,495 \$1,495
Custom Tailoring and Deviations - Exterior Color						
CDG	Switch Panel Package Painted Exterior Color Side air vents central air vents including switch trim. Leather finish interior color: defroster trim, side air vent slats, central air vent slats.			CDA CDN CMG CMN CNA EAA EAB EAC EAD EAE	Turbo Coupe Turbo Cabriolet	\$2,030 \$2,030
CDH	Door Finishers Painted in Exterior Color Paint finish in exterior color on front of door handle and door opener trim.			CLF CMH XTL XTT XTU XTV XTW	Turbo Coupe Turbo Cabriolet	\$830 \$830
CDJ	Gear Lever Trim in Exterior Color Paint finish in exterior color on decorative trim on gear lever/selector.			CMJ	Turbo Coupe Turbo Cabriolet	\$290 \$290
CDM	Trim Strip Painted in Exterior Color Paint finish in exterior color on trim strip switch panel, including cupholder trim.			CLE CMM CVP 801 802 803	Turbo Coupe Turbo Cabriolet	\$520 \$520
CDN	Air Vent Slats Painted in Exterior Color Paint finish in exterior color on side air vent slats and central air vent slats. Smooth leather finish in interior color on side air vents, central air vent including switch trim.			CDA CDG CMG CMN EAA EAB EAC EAD EAE	Turbo Coupe Turbo Cabriolet	\$940 \$940
CDP	Instrument Surround Painted in Exterior Color			CMP EAE XCL XNG	Turbo Coupe Turbo Cabriolet	\$440 \$440
CDR	Belt Outlet on B-pillars Painted in Exterior Color			CCW CDU CFE CFS CJJ CMR	Turbo Coupe Turbo Cabriolet	\$180 \$180

Option	Description	Must Pick	Required	Conflict	Model	Price (USD)
CER	PCM Handset Painted in Exterior Color Paint finish in exterior color on upper section. Smooth leather finish in interior color on lower section, including support (three-part).		668	CCR CED CFC	Turbo Coupe	\$535
				CFH CML XEA	Turbo Cabriolet	\$535
CGA	Headlight Cleaner Cover in Exterior Color				Turbo Coupe	\$200
					Turbo Cabriolet	\$200
CMC	Door Opener Painted in Exterior Color			CDC	Turbo Coupe	\$550
					Turbo Cabriolet	\$550
CNE	Spoiler Lip Painted Paint finish in exterior color: spoiler lip (standard)			DAJ	Turbo Coupe	\$585
					Turbo Cabriolet	\$585
CNF	Front Air Intakes Painted Paint finish in exterior color: front air intakes (left/center/right)			CNC DAJ	Turbo Coupe	\$1,000
					Turbo Cabriolet	\$1,000
CNG	Lower Part of Rear Apron Painted Paint finish in exterior color: lower part of rear apron (standard)			DAJ	Turbo Coupe	\$585
					Turbo Cabriolet	\$585
CUC	Painted Model Designation on Rear Lid Model designation on rear lid painted in exterior color.		498		Turbo Coupe	\$165
						Turbo Cabriolet
CUF	PCM Package Painted in Exterior Color Paint finish in exterior color on PCM trim, climate control trim, lower switch trim, and lower storage bin. Note: available in color to sample only on request.			CCP CMF CUR	Turbo Coupe	\$2,070
					Turbo Cabriolet	\$2,070
DAJ	Exterior Package Painted Paint finish in exterior color: spoiler lip (standard), front air intakes (left/center/right), lower part of rear apron (standard).		XAJ	CNC CNE CNF	Turbo Coupe	\$1,985
				CNG	Turbo Cabriolet	\$1,985
Custom Tailoring and Deviations - Black						
CDC	Door Opener Painted Black			CMC	Turbo Coupe	\$550
						Turbo Cabriolet
CMD	Rear Center Console Painted Black Paint finish in Black on rear section of center console, including ashtray cover, and storage tray on rear section of center console. Smooth leather finish in interior color on handbrake lever recess trim.			CME XCK XJT XJU	Turbo Coupe	\$1,130
				XME XMJ XMZ	Turbo Cabriolet	\$1,130

Option	Description	Must Pick	Required	Conflict	Model	Price (USD)
CMF	PCM package in Black Paint finish in Black: PCM trim[(4.0b)], climate control trim[(4.0c)], lower switch trim[(4.0d)], lower storage bin[(4.0e)]			CCP CUF CUR	Turbo Coupe	\$2,070
					Turbo Cabriolet	\$2,070
CMG	Switch Panel Package Painted Black Side air vents and central air vents including switch trim painted black. Leather finish interior color on defroster trim, side air vent slats and central air vent slats.			CDA CDG CDN	Turbo Coupe	\$2,030
				CMN CNA EAA	Turbo Cabriolet	\$2,030
				EAB EAC EAD EAE		
CMH	Door Finishers Painted Black Paint finish in Black on front of door handle and door opener trim. Note: recommended in conjunction with belt-outlet B-pillars painted Black.			CDH CLF XTL XTT	Turbo Coupe	\$830
				XTU XTV XTW	Turbo Cabriolet	\$830
CMJ	Gear Lever/Selector Trim Black			CDJ	Turbo Coupe	\$290
					Turbo Cabriolet	\$290
CML	PCM Handset Painted Black Paint finish in Black on upper section. Smooth leather finish in interior color on lower section, including support (three-part).	668		CCR CED CER	Turbo Coupe	\$535
					CFC CFH XEA	Turbo Cabriolet
CMM	Trim Strip Painted Black Paint finish in Black on trim strip switch panel including cupholder trim (five-part).			CDM CLE CVP	Turbo Coupe	\$520
				801 802 803	Turbo Cabriolet	\$520
CMN	Air Vent Slats Painted Black Paint finish in Black on side air vent slats and central air vent slats. Smooth leather finish in interior color on side air vents and central air vent including switch trim.			CDA CDG CDN	Turbo Coupe	\$940
				CMG EAA EAB	Turbo Cabriolet	\$940
				EAC EAD EAE		
CMP	Instrument Surround Painted Black			CDP EAE XCL XNG	Turbo Coupe	\$440
					Turbo Cabriolet	\$440
CMR	Belt Outlets on B-Pillars Painted Black			CCW CDR CDU	Turbo Coupe	\$180
				CFE CFS CJJ	Turbo Cabriolet	\$180
Custom Tailoring and Deviations - Other						
00471	Back Of Rear Seats Deviating Carpet Rear side of back seat backrest covered with carpet	25241 25351			Turbo Coupe	\$0
					Turbo Cabriolet	\$0
09991	All Exclusive Options with Deviating Stitching EXC-Options with deviations			970	Turbo Coupe	\$290
					Turbo Cabriolet	\$290

Option	Description	Must Pick	Required	Conflict	Model	Price (USD)
24891	Stitching of Front and Rear Seats in Deviating Color			25991 970	Turbo Coupe Turbo Cabriolet	\$1,020 \$1,020
24901	Stitching of Dashboard in Deviating Color	AT BK BM BP DF FE TG MB RA 05 06 07 99		25992 970	Turbo Coupe Turbo Cabriolet	\$240 \$240
24902	Stitching of Door Trim in Deviating Color	AT BK BM BP DF FE TG MB RA 05 06 07 99		25993 970	Turbo Coupe Turbo Cabriolet	\$240 \$240
24903	Stitching of Door Handle in Deviating Color Stitching of door handles and door storage compartment lid in deviating thread color.	AT BK BM BP DF FE TG MB RA 05 06 07 99		XTL XTT XTU XTW 25994 970	Turbo Coupe Turbo Cabriolet	\$470 \$470
24904	Stitching of Side Center Console in Deviating Color	AT BK BM BP DF FE TG MB RA 05 06 07 99		25995 970	Turbo Coupe Turbo Cabriolet	\$240 \$240
24905	Stitching of Rear Side Panel in Deviating Color	AT BK BM BP DF FE TG MB RA 05 06 07 99		25996 970	Turbo Coupe Turbo Cabriolet	\$310 \$310
24921	Upper Dash in Deviating Color Dashboard upper section and passenger airbag standard leather in deviating color.	24901 25992 00481		25731 640 970	Turbo Coupe Turbo Cabriolet	\$470 \$470
24922	Lower Dash in Deviating Color Dashboard lower section and glove compartment lid standard leather in deviating color.	AT BK BM BP DF FE TG MB RA 05 06 07 99		25252 970	Turbo Coupe Turbo Cabriolet	\$310 \$310
24923	Center Console Side Pads Standard Leather Deviating Col	24904 25995 00481		24924 25257 668 970	Turbo Coupe Turbo Cabriolet	\$160 \$160
24951	Carpet in Deviating Color			99 24961	Turbo Coupe Turbo Cabriolet	\$630 \$630
24961	standard carpet deviating color Deviating carpet out of standard offering, only with Interior code '99'		99	24951	Turbo Coupe Turbo Cabriolet	\$0 \$0
25221	Roofliner Deviating Color Alcantara			XMA	Turbo Coupe	\$310

Option	Description	Must Pick	Required	Conflict	Model	Price (USD)
25231	Front Seat Inlay in Alcantara Deviating Color			25241 25251 25351 25491 970 982	Turbo Coupe Turbo Cabriolet	\$550 \$550
25241	Front and Rear Seats in Leather Deviating Color	AT BK BM BP DF FE TG MB RA 05 06 07 99	00471	25231 25251 25351 25491 970	Turbo Coupe Turbo Cabriolet	\$1,500 \$1,500
25281	Door Airbag Cover Trim Strip Leather Deviating Color	AT BK BM BP DF FE TG MB RA 05 06 07 99		25253 970	Turbo Coupe Turbo Cabriolet	\$310 \$310
25431	Front window pillars and frame standard leather deviating	AT BK BM BP DF FE TG MB RA 05 06 07 99		970	Turbo Cabriolet	\$310
25461	A/B/C Pillars in Standard Leather	AT BK BM BP DF FE TG MB RA 05 06 07 99		970	Turbo Coupe	\$790
25491	Front and Rear Seat Inlays In Deviating Color	AT BK BM BP DF FE TG MB RA 05 06 07 99		25231 25241 25251 25351 970	Turbo Coupe Turbo Cabriolet	\$1,100 \$1,100
25631	Door trim standard leather deviating color	24902 25993 00481		970	Turbo Coupe Turbo Cabriolet	\$310 \$310
25731	Upper Dash with Sport Chrono Deviating Color Dashboard upper section and passenger airbag standard leather in deviating color.	24901 25992 00481	640	24921 970	Turbo Coupe Turbo Cabriolet	\$550 \$550
CUL	Wind deflector with colored Porsche logo Wind deflector with Porsche logo in exterior or interior color				Turbo Cabriolet	\$175
CXB	Door Entry Guards in Stainless Steel, Illuminated Door entry guards (left/right) in stainless steel with Turbo logo, illuminated in White.			CUA CXC CXD CXE X69 X70	Turbo Coupe Turbo Cabriolet	\$725 \$725
CXC	Door entry guards with personal logo, illuminated Door entry guards (left/right) in stainless steel with personal logo, illuminated in White. Note: please use special order form Door entry guards with personal logo in addition to the Exclusive special order.			CUA CXC CXD CXE X69 X70	Turbo Coupe Turbo Cabriolet	\$0 \$0

Option	Description	Must Pick	Required	Conflict	Model	Price (USD)
Exterior Cosmetic						
498	Deletion of model designation				Turbo Coupe Turbo Cabriolet	\$0 \$0
XAF	Aerokit Turbo Includes new front spoiler lip, new engine cover with rear spoiler and fixed wing profile. Paint finish in exterior color including standard side skirts and standard lower part of rear apron. Note: substantially reduces entry angle to gradients.			98 99 XAJ	Turbo Coupe	\$6,950
XAJ	Standard Rocker Panels Painted Rocker panels painted body color.			XAF	Turbo Coupe Turbo Cabriolet	\$750 \$750
XXF	Red Taillights Entirely red lens. Function and dimension of taillights are the same as standard taillights.				Turbo Coupe Turbo Cabriolet	\$640 \$640
Additional Options						
TD5	Tourist Delivery			900	Turbo Coupe Turbo Cabriolet	\$4,075 \$4,075