

# 70 68 19 Removing and installing C-pillar trim - as of MY 2005

- [Preliminary work](#)
- [Removing C-pillar trim](#)
- [Installing C-pillar trim](#)
- [Subsequent work](#)

[top of page](#)

## Preliminary work

### Preliminary work

1. Remove rear side trim panel. [707519 Removing and installing rear side trim panel - chapter on "Removing"](#)
2. Remove rear roof trim panel. [708519 Removing and installing rear roof trim panel - chapter on "removing" \[997110 997111 997120 997121 997410 997411\]](#) [708519 21 Removing and installing rear roof trim panel - chapter on "removing" \[997430 997431\]](#)
3. Remove seat belt and rear mounting component. [691219 Removing and installing rear three-point belt - chapter on "Removing"](#)

[top of page](#)

## Removing C-pillar trim

### Removing C-pillar trim panel

**Installation Location:**

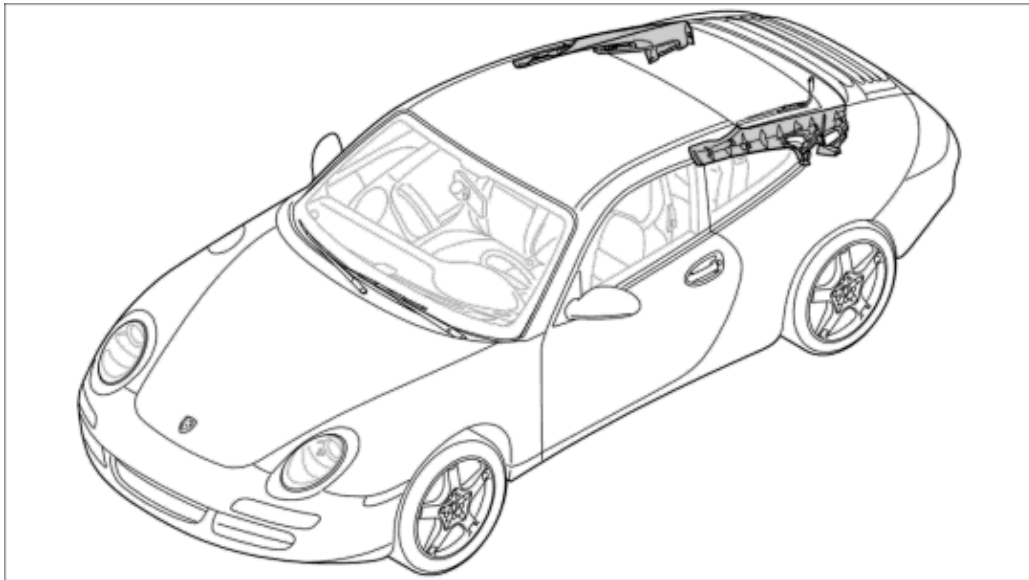

*Installation position for C-pillar trim panel*

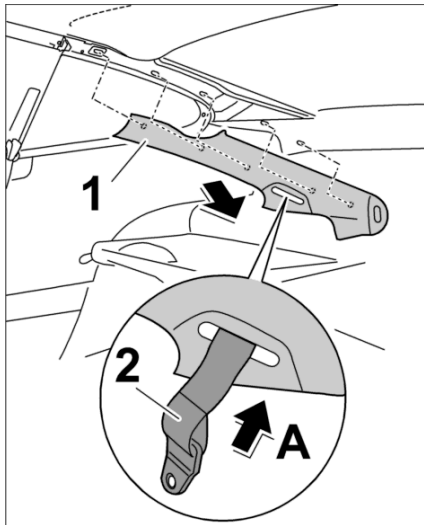

*Removing C-pillar trim panel*

1. Pull C-pillar trim panel **-1-** inwards.
2. Thread seat belt with mounting component **-2-** through the C-pillar trim panel **-Arrow A-** .
3. Remove C-pillar trim panel **-1-** .

top of page

## Installing C-pillar trim

## Installing C-pillar trim panel

### Installation Location:

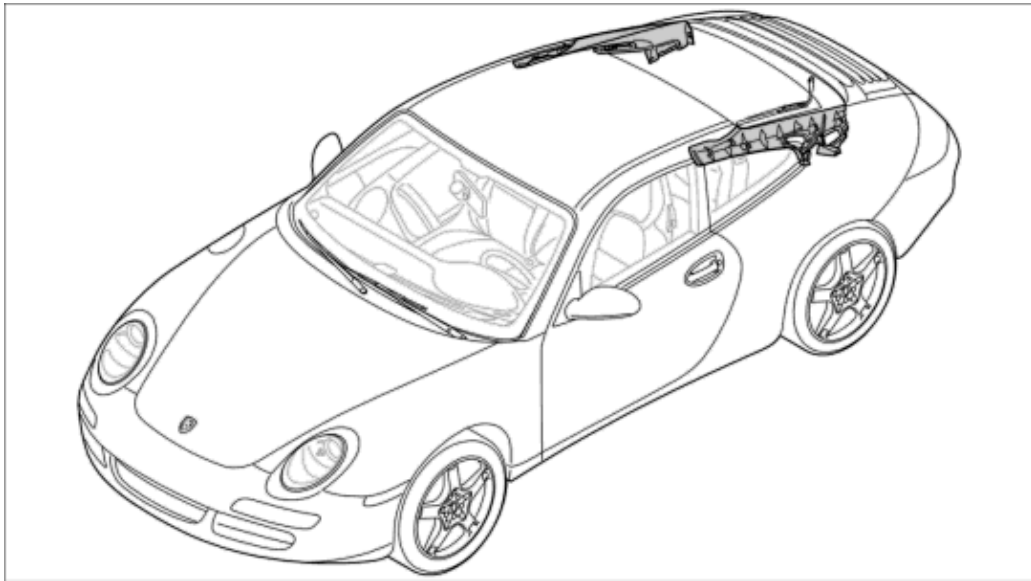

*Installation position for C-pillar trim panel*

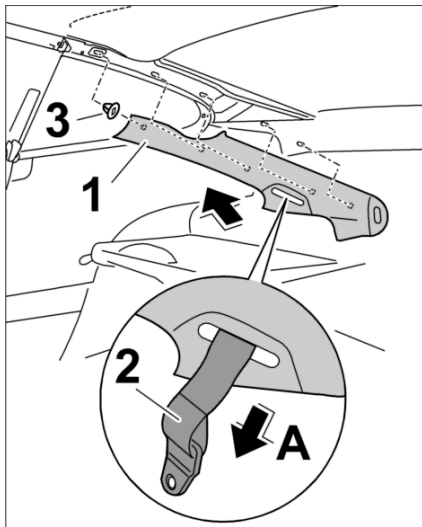

*Installing C-pillar trim*

1. Check sheetmetal clips **-3-**, replacing if necessary.
2. Thread seat belt with mounting component **-2-** through the C-pillar trim panel **-1-** **-Arrow A-**.
3. Position C-pillar trim panel **-1-** on the C-pillar and clip in.

[top of page](#)

## Subsequent work

### Subsequent work

1. Install seat belt and rear mounting component. 691219 Removing and installing rear three-point belt - chapter on "Installing"
2. Install rear roof trim panel. 708519 Removing and installing rear roof trim panel - chapter on "Installing" [997110 997111 997120 997121 997410 997411] 708519 23 Removing and installing rear roof trim panel - chapter on "Installing" [997430 997431]
3. Install rear side trim panel. 707519 Removing and installing rear side trim panel - chapter on "Installing"

---

997110, 997111, 997120, 997121, 997410, 997411, 997430, 997431

as of MY 2005

Country C00, C02, C05, C07, C08, C09, C10, C11, C12, C13, C14, C15, C16, C18, C19, C20, C21, C22, C23, C24, C25, C26, C27, C28, C32, C33, C34, C35, C36, C37, C38, C39, C45, C46, C98, C99



WARNUNG

**Gefahr des Verlusts der Text-Bild-Zuordnung beim Ausdruck.**

- **Aus technischen Gründen kann derzeit nicht ausgeschlossen werden, dass trotz einwandfreier Darstellung auf dem Bildschirm beim Ausdruck der Zusammenhang von Text und zugehörigem Bild verloren geht.**
- **Wird der Fehler nicht bemerkt, besteht die Gefahr, daß Arbeiten nicht korrekt durchgeführt werden und es dadurch zu Personen- und Sachschäden kommt.**

Vergleichen Sie deshalb nach dem Druckvorgang unbedingt die Ausdrücke mit der Bildschirmdarstellung. Korrigieren Sie die Ausdrücke im Fehlerfall so, daß der Inhalt der Bildschirmdarstellung zutreffend wiedergegeben wird.



WARNING

**Danger of losing text-figure correspondence when printing out.**

- **For technical reasons, it can currently not be ruled out that the correspondence between text and associated figure can be lost when it is printed out, even though the display on the screen is correct.**
- **If the fault is not noticed, there is the danger that work will not be performed correctly which can cause injury and damage.**

Therefore, always compare printouts with the screen display after printing them out. Correct the printouts if they are faulty so that the content of the screen display matches that on the printouts.



**AVERTISSEMENT**

**Risque de perte de la correspondance texte-illustration lors de l'impression papier.**

- **Pour des raisons techniques, il ne peut pas être exclu à l'heure actuelle que, même en cas d'affichage correct à l'écran, la correspondance entre le texte et l'illustration puisse être erronée sur l'impression papier.**
- **Si l'erreur passe inaperçue, on court le risque d'exécuter certaines opérations de manière incorrecte pouvant conduire à des dommages corporels et matériels.**

Comparez impérativement pour cette raison les impressions papier avec l'affichage à l'écran. Corrigez-les en cas d'erreur de manière à reproduire correctement l'affichage à l'écran.



**ATTENZIONE**

**Pericolo di perdita dell'abbinamento testo-immagine nella stampa.**

- **Per motivi tecnici non è escluso che, nonostante la rappresentazione sullo schermo risulti perfetta, durante la stampa venga persa la corrispondenza fra testo e relativa immagine.**
- **Se tale difetto non viene rilevato vi è il pericolo che i lavori non siano eseguiti correttamente; ciò può avere come conseguenza lesioni e danneggiamenti.**

Per questo motivo, dopo la stampa è assolutamente necessario confrontare le stampe con la rappresentazione sullo schermo. In caso di errore si prega di correggere le stampe, così da garantire la riproduzione esatta della rappresentazione sullo schermo.



**ADVERTENCIA**

**Al imprimir se corre el riesgo de perder la correcta asignación de las figuras al texto.**

- **Por motivos técnicos, por el momento no se puede descartar que, aun siendo correcta la imagen que aparezca en la pantalla, al imprimir se pierda la correlación entre el texto y la figura correspondiente.**
- **Si este error pasara desapercibido, existe el riesgo de que los trabajos no se ejecuten de forma correcta y, por tanto, se produzcan daños personales y materiales.**

Por ello le rogamos que tras el proceso de impresión compare siempre las copias impresas con la imagen de la pantalla. En caso de error, corrija las copias impresas de forma que se correspondan con el contenido de la imagen de la pantalla.