

**911 Carrera**  
**911 Carrera S**  
**911 Carrera 4**  
**911 Carrera 4S**

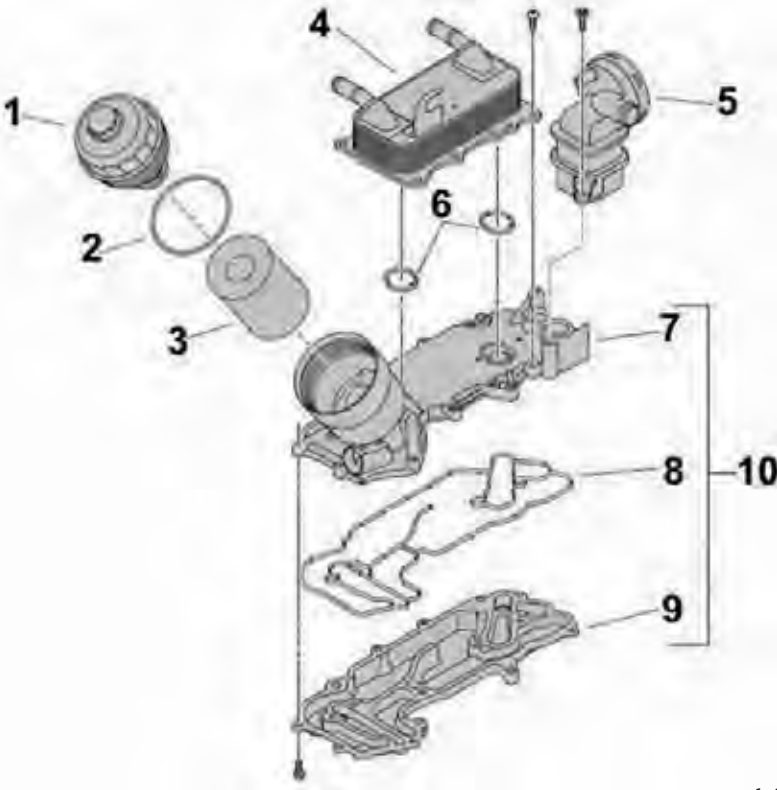

- 1 Oil filter cover
- 2 Sealing ring
- 3 Oil filter element
- 4 Heat exchanger
- 5 Oil mist separator
- 6 Seal
- 7 Pre-separator, top part
- 8 Seal
- 9 Pre-separator, bottom part
- 10 Pre-separator



1\_25\_09