

Subject	Page
General Information	2
Oil Types and Capacities	3
Operation	4
Gearshift Strategy	6
Transmission Gear Layout	10
Synchronization	11
Shifting	13
Power Flow	15
Doppelkupplung	16
Hydraulics	17
Sensors	19
PDK Shift Lever	21

PDK Transmission

Porsche Doppelkupplung (PDK)

This technical description covers the design and operating principle of the 7-speed dual-clutch transmission, called PDK (**P**orsche **D**oppel **K**upplung) at Porsche. Since this transmission is used in several different Porsche models, only the basic functions will be described here.

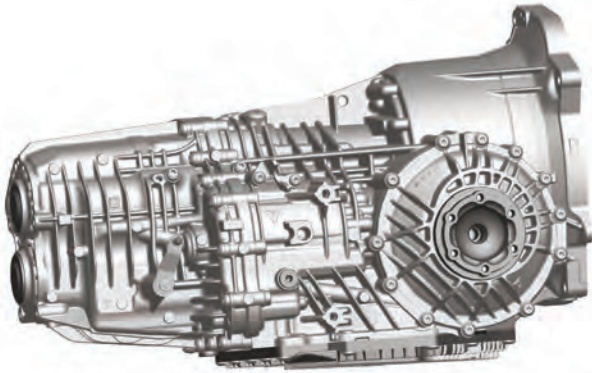

Boxster/Cayman (987)

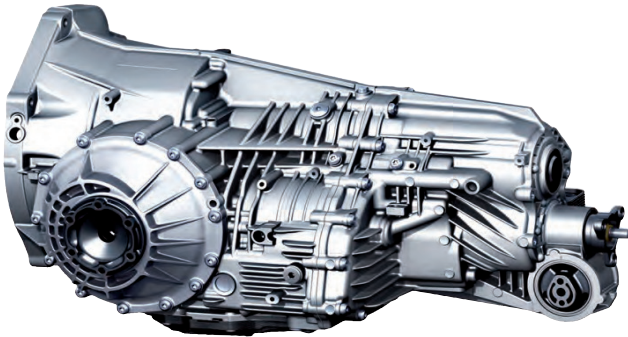

911 Carrera (997)

Introduction

Porsche has worked with Doppelkupplung transmissions since the '70s. The first racing car with PDK was used in 1984 in the Porsche 956 at Nürburgring, while Porsche had its first big win with a PDK transmission in 1986 with the enhanced 962 in Monza. The main advantage over rival vehicles was that gearshifts could be accomplished without interrupting tractive power. This allowed shorter shifting times with significantly improved acceleration for the racing car. This type of transmission proved successful during the highly challenging long-distance World Championships, although two dry clutches were used. The high level of lining wear associated with this type of clutch was not an issue since the clutch plates would be replaced immediately after each race.

Standard development was not followed up at that time as control electronics systems and computer capacities in the '80s were not yet sophisticated enough to perform the complex control functions that were essential to meet the comfort requirements for road vehicles. Also, the mechanical control elements for precise hydraulic valve control were not yet fully developed or financially viable at that time.

General Information

The Porsche Doppelkupplung transmission (PDK) is both a manual and automatic transmission. The special feature of PDK is that two gears can always be engaged one gear is engaged while driving and the next potential gear is already pre-selected.

When shifting, the clutch on the active gear opens while the other clutch engages the pre-selected gear at the same time. This happens under load and so quickly that the power flow is permanently available. Due to its fast gear changes without any significant power flow interruption, the 7-speed Doppelkupplung transmission offers much better driving dynamics than a conventional manual transmission, with the convenience of an automatic transmission.

The superbly sporty driving dynamics are complemented by a high level of efficiency, which results in reduced fuel consumption compared with a conventional manual transmission in certain driving situations. PDK transmission is available for the MY 2009 Boxster/Cayman (987) and for both the rear-wheel-drive and all-wheel-drive 911 Carrera models.

Oil Types/Oil Capacity/Oil Change Intervals

Due to high shearing strains that occur in the differential, two different oil chambers are used in the Porsche Doppelkupplung transmission.

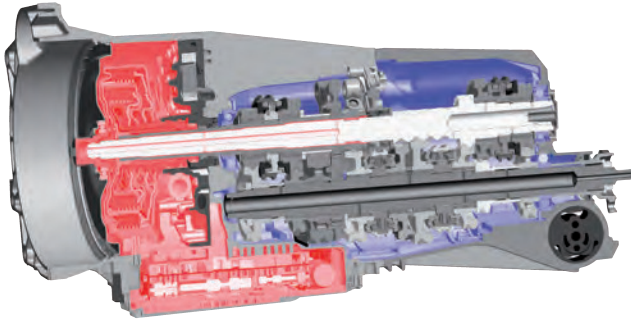

The oil chamber for hydraulic oil is shown in red, while the oil chamber for gear wheel oil is shown in blue in the illustration above.

2.95 liters of Mobilube PTX Formula A (SAE 75W-90) GL4.5 are used in the transmission for lubricating the gear wheel set. 5.2 liters of Pentosin Gear Oil FFL3 are used as hydraulic oil.

The change interval is 56,000 miles (90,000 km) for hydraulic oil and 112,000 miles (180,000 km) for gear wheel oil.

Oil Filling

The correct hydraulic oil level is important for operating the transmission without running into problems. The following preconditions must be met in order to check or correct the oil level:

- Engine must be idling
- Vehicle must be horizontal in both longitudinal and transverse axis
- Hydraulic oil temperature between 86° F. and 104° F. (30° C and 40° C)
- Selector-lever position "P"
- Clutch cooling volume flow must be switched off (using PIWIS Tester in Oil fill mode)
- Retain the described states for approx. 1 minute to allow the oil to settle
- Open screw plug on oil overflow bore and collect emerging oil until only drops of oil are emerging
- Once there is no more oil emerging, top up the clutch fluid until oil emerges at the oil overflow bore
- To avoid damaging the clutches, the procedure must be completed within 5 minutes (PIWIS Tester exits Oil fill mode automatically after 5 minutes)



The correct oil level is also important to avoid damaging the gear wheels in the transmission. There is also an overflow bore (1) for this, which is located on the opposite side. The oil level can be checked in the usual way here.

Notes:

PDK Transmission

Transmission Concept

In principle, a “Doppelkupplung” (double clutch) transmission can be understood as a parallel-switched transmission made up of two fully synchronized shift-sleeve transmissions (transmission 1 and transmission 2).

Each transmission has its own clutch:

- Transmission 1, clutch K1 (outer clutch)
- Transmission 2, clutch K2 (inner clutch)

Transmission 1 switches the odd-numbered gears 1, 3, 5, 7 and reverse gear. Transmission 2 switches the even-numbered gears 2, 4 and 6. Basically, only one transmission is ever engaged via the relevant clutch when the vehicle is driving.

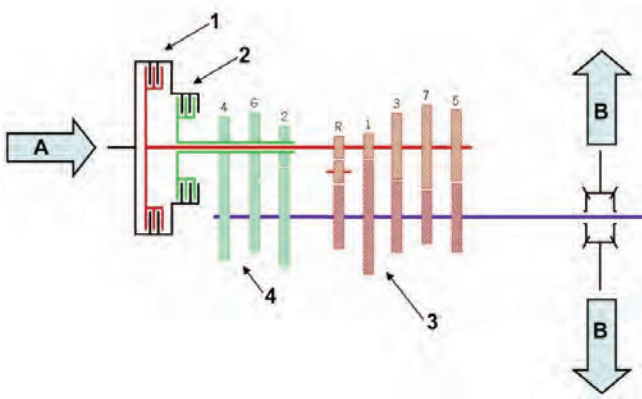

- 1 Multiple-disc clutch 1
- 2 Multiple-disc clutch 2
- 3 Transmission 1
- 4 Transmission 2
- A Force input
- B Force output

Operation

Like the Porsche Tiptronic transmission used in the previous models, PDK has two selector gates. Upshifts and downshifts are performed automatically in the right-hand gate and in selector-lever position “D”. If the selector lever is moved into the left-hand gate (“M”), upshifts and downshifts can be performed manually. Gears can be changed both on the steering wheel and using the selector lever.

There is no gear lock on vehicles with PDK, which means that selector-lever positions P - R - N - D are available.



- P = Park
- R = Reverse
- N = Neutral
- D = Drive (automatic shifting:
1st – 2nd – 3rd – 4th – 5th – 6th – 7th gear)

3-Spoke Sports Steering Wheel for PDK



A new 3-spoke sports steering wheel for PDK is used in conjunction with the Doppelkupplung transmission on the new 9x7 models. This completely redesigned steering wheel has two sliding switches, which are incorporated neatly and conveniently into the steering-wheel spokes. Pressing these switches forward changes up a gear, and pulling them or pressing them towards the driver from the back of the steering wheel changes down a gear. It makes no difference whether the left or right sliding switch is used for changing gears. The switches can also be used to activate the “One-touch Hold function” (see Special functions).

Display in Instrument Cluster for PDK

Gearshifts for the new Doppelkupplung transmission are displayed in the instrument cluster. The shift indicator is based on an enhanced Tiptronic S concept. In addition to the usual selector-lever position display (Drive mode) via red LEDs, the new instrument cluster also has a numeric gear display.

Other displays in the instrument cluster:

- A flashing selector-lever position in the instrument cluster means that the selector lever is between two positions.
- Transmission temperature too high prompts the driver to change his driving style. “Warning jerks” can be felt when driving off and the engine power may be restricted. Do not hold the vehicle on a hill, for example, using the accelerator use the brake pedal instead. Reduce engine load. Stop the vehicle in a suitable place if necessary, and allow the engine to run in selector-lever position “N” or “P” until the warning disappears.
- “Transmission emergency run” in white letters means that the vehicle can still be driven, but contact a authorized Porsche dealer.
- “Transmission emergency run” in red letters means that the vehicle can be driven to a stop, but cannot be driven further.



Boxster/Cayman (987)



911 Carrera (997)

PDK Transmission

Gearshift Strategy

The center console includes a Sport and Sport Plus button. The basic gearshift characteristics change, depending on which button is pressed.



Driving in selector-lever position “M”, Sport and Sport Plus button not active – Upshifts and downshifts can be performed both on the steering wheel and using the selector lever. Gearshift comfort is therefore adaptive over the entire operating range and adapts to suit the driver's individual driving style. For improved gearshift comfort, the engine torque is reduced while changing gears. Downshifts in deceleration state are accomplished with **very little** intermediate throttle application and are therefore hardly audible. To avoid under-revving and the associated loss of driving comfort, the current gear is switched down to the next lower gear at engine speeds of less than approx. 1,200 rpm. An upshift at the engine speed limit is only accomplished if there is a kickdown in the speed limiting range (panic shifting). The vehicle always moves off in 1st gear. The Launch Control function (racing start) is not available.

Driving in selector-lever position “M”, Sport button active – Upshifts and downshifts can be performed both on the steering wheel and using the selector lever. Gearshift comfort is thus adaptive over the entire operating range and adapts to suit the driver's individual driving style, but basic sportiness is increased. The engine torque is reduced only slightly while changing gears. Downshifts in deceleration state are accomplished with intermediate throttle application. To avoid under-revving and the associated loss of driving comfort, the current gear is switched down to the next lower gear at an engine speed of less than approx. 1,200 rpm. An upshift at the engine speed limit is only accomplished if there is a

kickdown in the speed limiting range (panic shifting). The vehicle always moves off in 1st gear. The Launch Control function (racing start) is not available.

Driving in selector-lever position “M”, Sport Plus button active – Upshifts and downshifts can be performed both on the steering wheel and using the selector lever. Gearshifts are not adaptive and are purely performance-oriented with a loss of comfort. In addition, the engine torque is not reduced while changing gears. Downshifts in deceleration state involve quick and audible intermediate throttle application with a sporty sound. To avoid under-revving and the associated loss of driving comfort, the current gear is switched down to the next lower gear at an engine speed of less than approx. 1,200 rpm. An upshift at the engine speed limit is only accomplished if there is a kickdown in the engine speed limit range (panic shifting). The vehicle always moves off in 1st gear. 7th gear is **not** used in this program. The Launch Control function (racing start) is available.

Driving in selector-lever position “D”, Sport and Sport Plus button not active – When the selector lever is moved to position “D”, an extremely intelligent driving program is activated. Shifting adapts continuously and almost seamlessly to the driving style and route profile over the entire operating range. Gearshifts and gear-changing speeds here are changed from economic/comfortable to sporty. Gearshifts are essentially performed with more emphasis on comfort. Also for improved comfort, the engine torque is reduced during upshifts and downshifts. Downshifts in deceleration state and deceleration downshifts are accomplished with **very little** intermediate throttle application and are therefore hardly audible. The vehicle moves off in 1st gear.

Driving in selector-lever position “D”, Sport active – An extremely intelligent driving program is also activated in this position and shifting adapts continuously and almost seamlessly to the driving style and route profile over the entire operating range. Basic sportiness is increased with faster pick-up and slower deceleration. Gearshifts are more performance-oriented and the engine torque is only reduced slightly during upshifts and downshifts. Downshifts in deceleration state and deceleration downshifts are accomplished with intermediate throttle application and are therefore audible. The vehicle moves off in 1st gear. 7th gear is avoided for the most part and is engaged only at higher speeds.

Driving in selector-lever position “D”, Sport Plus

active – Shift map adaptations are not active in this program. The most sporty map is activated permanently. Gearshifts are performance-oriented with reduced gearshift comfort. Downshifts in deceleration state and deceleration downshifts are accomplished with intermediate throttle application and are thus very audible. Gearshifts are performance-oriented and the engine torque is not reduced during upshifts and downshifts. The vehicle moves off in 1st gear. 7th gear is not available. The racing start function is available.

Adaptation of Gearshift Characteristics to Driving Style and Route Profile

Various measured values, such as accelerator pedal position, accelerator pedal change speed, axial and lateral acceleration, vehicle speed and engine speed as well as the steering angle, are used to adapt the gearshift characteristics almost continuously to the driving style and route profile. This adaptation is performed in “Normal” mode (no sport buttons pressed) and sometimes in “Sport” mode. No adaptation is performed in “Sport Plus” mode. When this adaptation is selected, the shift programme not only takes the driving style into consideration, but also road resistance. Changes in road resistance are particularly noticeable when driving uphill and on downward slopes. In addition, the PDK control unit forms an altitude correction factor, i.e. since the volumetric efficiency of the engine decreases as the altitude increases, the driver automatically accelerates more and the transmission would switch to a more shift-conducive map. This is detected by the altitude sensor and the optimal map is made available to the driver.

Special Functions

- **Launch Control (racing start function)**

This function is available both in selector-lever position “D” and “M” in Sport Plus mode. Preconditions are as follows: Vehicle is stationary, brake is applied, kickdown is active. The function is triggered by releasing the brake. The Doppelkupplung in the transmission now enables optimum wheel slip at maximum acceleration.

Stress on components increases significantly when driving off at maximum acceleration in comparison with driving off “normally”. In addition, there is a high temperature burden on the components in the clutches. To protect the components in this case, this function is disabled for a distance of 1.5 miles (2,5 km) after a racing start. During the 1.5 miles (2,5 km) drive, the clutches are cooled with the maximum cooling volume flow.

- **Prevention of downshifts in overrun state, e.g. approaching a corner (Fast Off)**

If the driver decelerates, i.e. releases the accelerator pedal quickly, when approaching a corner, the currently engaged gear is retained. If the driver also actuates the brake now, downshifts adapted to the vehicle speed are performed so that engine braking support is available when approaching a corner and the vehicle can be accelerated out of the corner in the optimum gear. If the accelerator pedal is now moved towards throttle valve “open” again, gearshifts are performed once again according to the driver request.

This function responds differently, depending on which mode was selected. If “Normal” mode is selected, the function is only activated for a high negative accelerator pedal gradient. In “Sport” mode, the function is activated for a medium negative accelerator pedal gradient, while it is activated for a low negative accelerator pedal gradient in “Sport Plus” mode.

- **Downshifts while braking (Fast Back)**

A downshift is initiated immediately if the driver switches quickly (within approx. 1 second) from accelerating to braking. However, the sportiness characteristic and the selected mode dictate how early a downshift is initiated.

PDK Transmission

Special Functions (cont'd)

- **Gear retention while cornering**

The lateral-acceleration sensor (single component with rotation-rate sensor), which is located under the centre console and works for the PSM system, is used to detect lateral acceleration and retain the engaged gear and lateral acceleration in the relevant gear, depending on the shift map.

- **Active switching to a sporty gear-changing map**

For increased spontaneity, the system switches to a sporty and dynamic shift map when the driver uses fast, positive accelerator pedal movements. The previous map is then activated again afterwards. This function is intended, for example, for situations in which a driver is driving at an extremely comfortable speed on a country road, but now decides to overtake and wants the vehicle to drive dynamically for a short time.

- **Manual momentary intervention in selector-lever position "D"**

To enable manual downshifts even in the automatic gear-selection gate, e.g.:

- when approaching a corner
- when entering speed zones/small towns
- when driving downhill

the upshift and downshift buttons (both on the steering wheel and on the selector lever) are active in the automatic gear-selection gate. In other words: PDK transmission switches to the manual program when the corresponding button is pressed. "M" appears in the instrument cluster and the requested gearshift is performed. At the same time, an 8-second timer is started in the control unit. If the upshift or downshift button is pressed again within this 8 seconds, the timer is restarted. The PDK transmission automatically switches back to Automatic mode ("D" appears in the instrument cluster) if:

- the timer runs out, no cornering is performed and the vehicle is not in deceleration state
- the selector lever is moved from "D" to "M" and back to "D"

Automatic upshifts and downshifts at the engine speed limits remain active. The deceleration downshift function is also active.

Warm-up Program

The warm-up map is a shift program with raised gear-changing points, which has the effect of heating the catalytic converters to their operating temperature as quickly as possible. Even the engine and transmission reach their operating temperature more quickly with this map. The coolant temperature of the engine is checked when the engine is started. If this is less than approx. 68° F. (20° C), the warm-up program is activated and is deactivated again when the coolant temperature is 86° F. (30° C).

Overheating Protection

Various measures are implemented on the transmission in order to protect the transmission and Doppelkupplung from overheating. The temperature sensor, which is fitted above the hydraulic control unit and measures the oil sump temperature, is used for this purpose. A calculation model, which calculates the clutch temperature from the engine torque and the slip at the clutch, is also used.

Overheating protection is activated in several stages and actively prompts the driver to adapt his driving style. Clearly perceptible jerking occurs in the first stage due to continuous opening and closing at drive-off and crawling speed, thereby prompting the driver to change the driving situation. Engine torque and kickdown rpm are also reduced. This is not displayed in the instrument cluster. A fault is stored in the control unit. If the temperature continues to rise, stage two is activated. This means that jerking continues. The engine torque and kickdown revs are reduced more drastically in this case. The white warning "Transmission temperature too high" appears in the instrument cluster and another fault is stored in the fault memory.

If the temperature rises even further, the red warning "Transmission emergency run" appears in the instrument cluster. A short time later, the Doppelkupplung is opened completely and power transmission is no longer available. Another fault is stored in the fault memory. If the driver now presses the accelerator, the vehicle will drive off, but not with the usual level of comfort. After implementing these measures, the transmission activates a special shift program in which gear changes are performed very slowly, with a high level of discomfort. Once the temperature falls below a certain temperature threshold, the transmission reverts to its normal program.

PDK Transmission

Basic Transmission

In order to avoid unnecessary duplication, we'll use a 911 Carrera PDK transmission in this section.

Gear Wheel Set

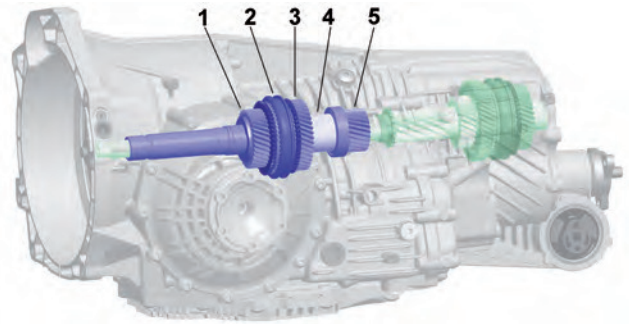

- 1 Loose gear wheel for 4th gear
- 2 Synchronizing hub with synchronization
- 3 Loose gear wheel for 6th gear
- 4 Spacer
- 5 Fixed gear wheel for 2nd gear

The illustration above shows the structure of input shaft 2

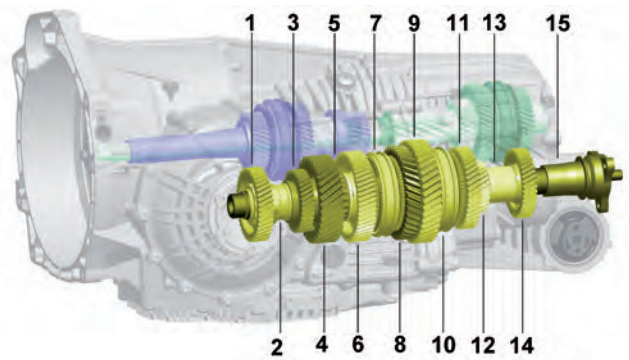

- 1 Fixed gear wheel for 4th gear
- 2 Spacer
- 3 Fixed gear wheel for 6th gear
- 4 Constant gear wheel
- 5 Bearing plate bearing
- 6 Loose gear wheel for 2nd gear
- 7 Synchronizing hub with synchronization
- 8 Loose gear wheel for reverse gear
- 9 Loose gear wheel for 1st gear
- 10 Synchronizing hub with synchronization
- 11 Loose gear wheel for 3rd gear
- 12 Fixed gear wheel for 7th gear
- 13 Spacer
- 14 Fixed gear wheel for 5th gear
- 15 Output flange

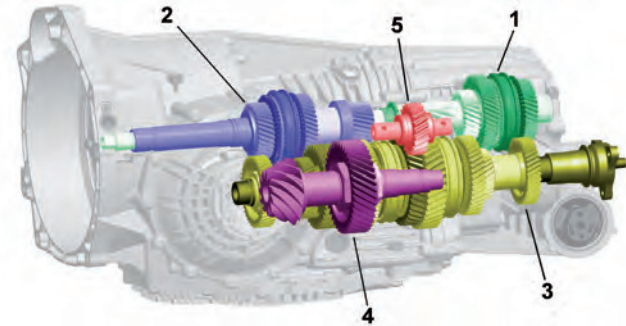

- 1 Drive shaft 1
- 2 Drive shaft 2
- 3 Main shaft
- 4 Pinion shaft
- 5 Intermediate gear wheel

The gear wheel set in the transmission comprises input shaft 1 (1), input shaft 2 (2), the main shaft (3), the pinion shaft (4) and the intermediate gear wheel (5).

1st, 3rd, 5th, 7th and reverse gear are on input shaft 1, while 2nd, 4th and 6th gear are on input shaft 2.

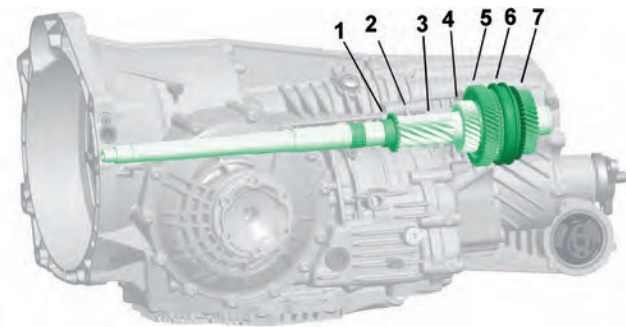

- 1 Sensor wheel
- 2 Fixed gear wheel for reverse
- 3 Fixed gear wheel for 1st gear
- 4 Fixed gear wheel for 3rd gear
- 5 Loose gear wheel for 7th gear
- 6 Synchronizing hub with synchronization
- 7 Loose gear wheel for 5th gear

The illustration above shows the structure of input shaft 1

Synchronization

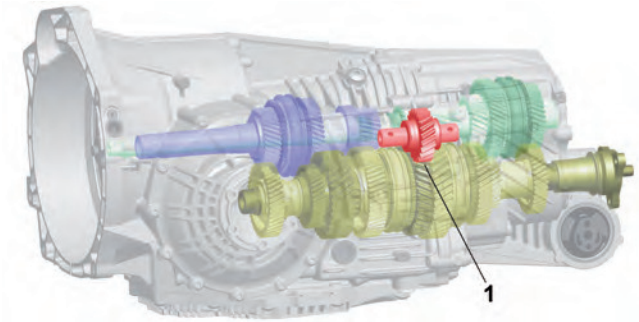

The direction change for reverse gear is accomplished via an intermediate gear wheel (1), which is located between input shaft 1 and the main shaft.

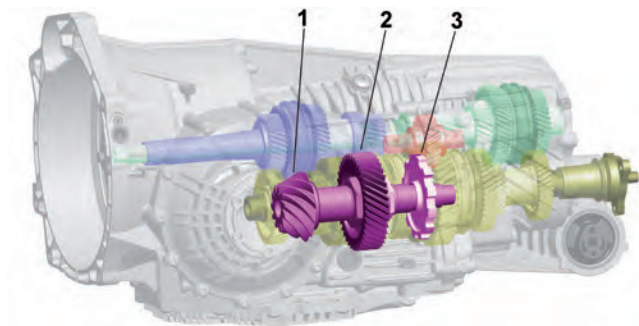

- 1 Bevel gear
- 2 Constant gear wheel
- 3 Parking-lock gear

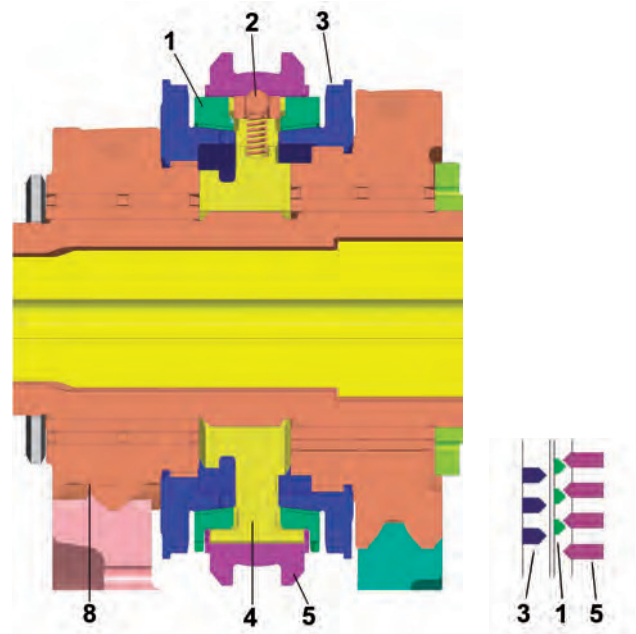

- 1 Synchronizer ring
- 2 Ball
- 3 Clutch hub
- 4 Guide sleeve
- 5 Operating sleeve
- 6 Spring
- 7 Pressure piece
- 8 Loose gear wheel

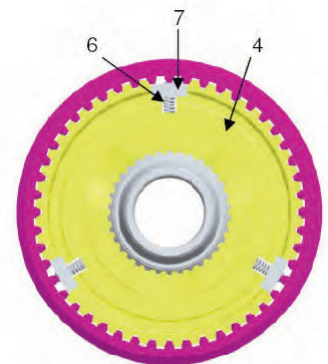

Basic operating principle of servo-lock synchronization – Synchronization in neutral position. The ball (2) holds the operating sleeve (5) in neutral.

When changing gears, the operating sleeve (5) is moved (to the left in the example shown) using the shift fork of the selected gear. The operating sleeve presses the synchronizer ring (1) against the friction cone of the clutch hub (3) via the pressure piece (7). At this moment, the synchronizer ring turns until it reaches a stop (not shown in the illustration). This blocks the movement of the operating sleeve.

Synchronization of Reverse, 1st, 2nd and 3rd Gear

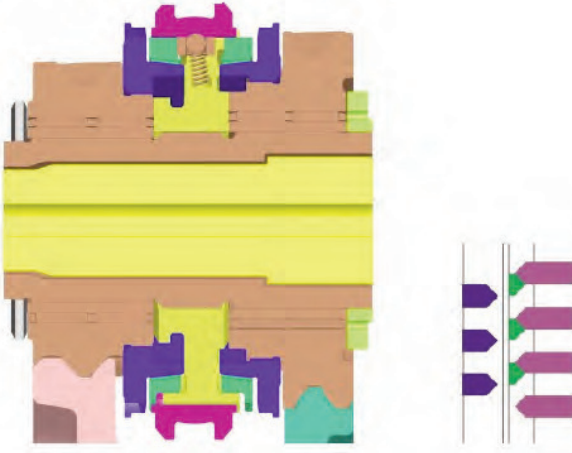

The synchronizer ring (1) continues to block the operating sleeve for as long as there is a difference in speed between the clutch hub (3) and operating sleeve. The synchronizer ring can only be turned back through the operating sleeve when the speed is the same. The latter is then moved on slightly to the clutch hub. The gear is engaged.

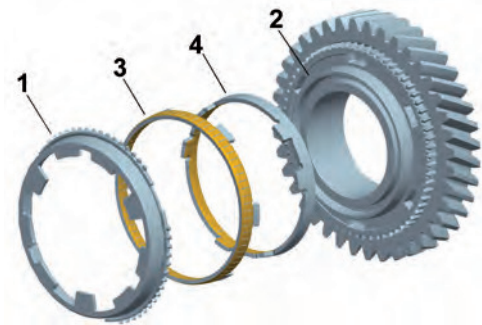

- 1 Synchronizer ring
- 2 Friction cone for loose gear wheel
- 3 Intermediate ring
- 4 Inner ring

Triple cone synchronization is used for reverse, 1st, 2nd and 3rd gear. The use of three friction cones has resulted in a considerable reduction in synchronizing forces. This reduces shifting forces when engaging gears. The first friction cone comprises the friction cone of the clutch hub of the loose gear wheel (2) and the inner cone of the inner ring (4). The second friction cone comprises the outer cone of the inner ring (4) and the inner cone of the intermediate ring (3). The third friction cone comprises the outer cone of the intermediate ring (3) and the inner cone of the synchronizer ring (1).

Synchronization of 4th, 5th, 6th and 7th Gear

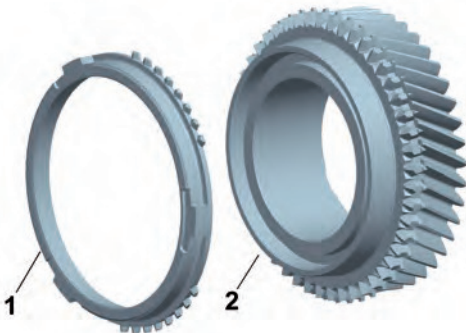
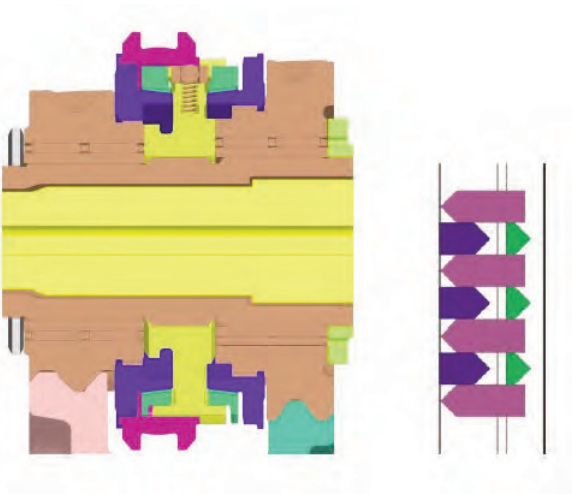

- 1 Synchronizer ring
- 2 Friction cone for loose gear wheel

Single cone synchronization is used for 4th, 5th, 6th and 7th gear. The cones from the clutch hub (2) and the cones of the synchronizer rings (1) form the friction cone.

Final Drive and Differential

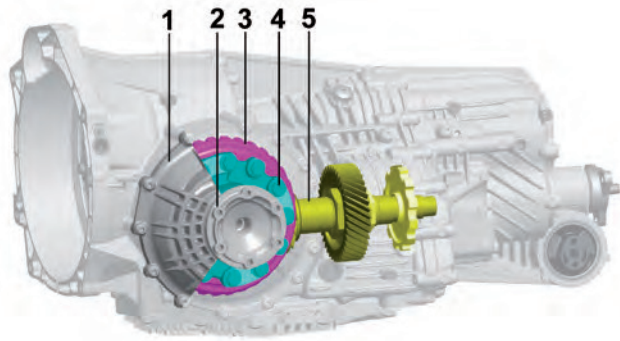

- 1 Cover
- 2 Flange
- 3 Ring gear
- 4 Differential
- 5 Pinion shaft

The illustration above shows the position of the final drive in the transmission.

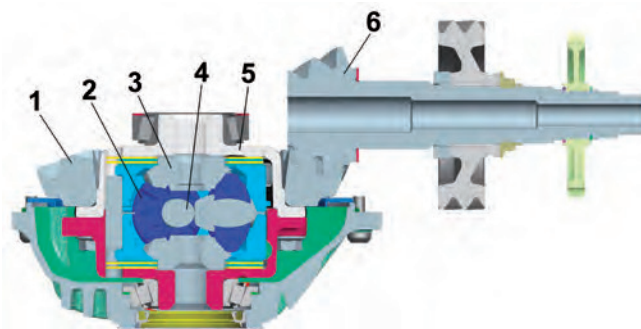

- 1 Ring gear
- 2 Differential pinions
- 3 Shaft bevel gears
- 4 Planet-gear carrier
- 5 Discs
- 6 Pinion

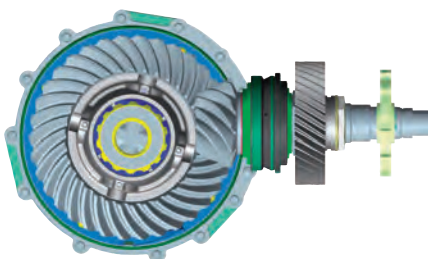

The final drive is designed as a hypoid drive. A limited-slip differential with a lock value of 22% in traction and 27% in deceleration is available as optional equipment instead of the standard differential.

Shifting

The shift rods are actuated hydraulically and are used to switch the synchronizers and therefore to change gears. They transfer the shifting forces generated in the actuator hydraulics to the actuating elements for synchronization. Each shift rod actuates two synchronizers and two gears. Once the gear is engaged, the shift rod is depressurized. The gear is held securely and without strain by detent in traction/deceleration mode by the form fit of the toothings.

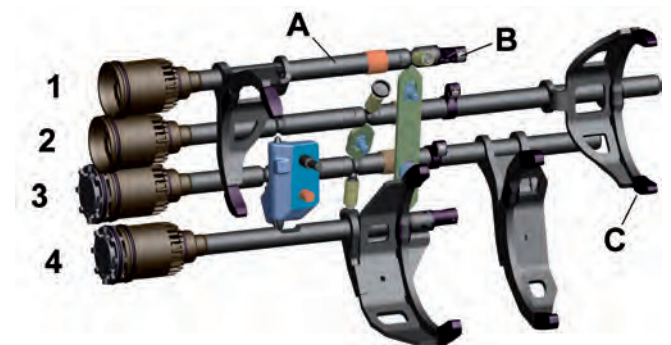

- 1 Shift rod for gears 4 and 6
- 2 Shift rod for gears 5 and 7
- 3 Shift rod for gears 1 and 3
- 4 Shift rod for gears 2 and reverse
- A Shift rod
- B Magnet
- C Shift fork

The shift rods are in neutral and the end positions are locked. Shift travel from neutral into the locked engage positions of the gears is nominally the same for all shift rods. The mechanical neutral position is nominally 0 mm shift travel, in accordance with the characteristic of the transmission distance sensors. Each shift rod has a sensor magnet for recording shift travel via the transmission distance sensors.

PDK Transmission

Locking

The shift rods in a transmission are locked against each other. In transmission 1, shift rod 3 (1st/3rd gear) is locked against shift rod 2 (5th/7th gear). In transmission 2, shift rod 1 (4th/6th gear) is locked against shift rod 4 (2nd/reverse gear). Reverse gear is also locked against all forward gears.

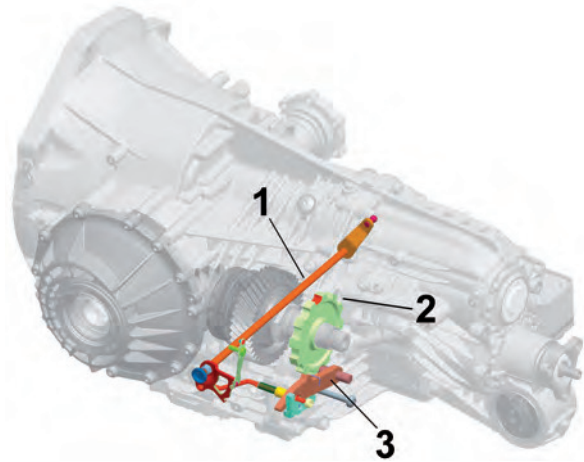

- 1 Selector shaft
- 2 Parking-lock gear
- 3 Catch

Parking Lock

Even if the vehicle is in gear, it cannot be prevented from rolling back in the same way as on a manual transmission because the clutches are opened in a depressurized state and therefore do not stop the vehicle from moving. The parking lock prevents the vehicle from rolling away, as with an automatic transmission.

When the vehicle is stationary, the parking lock is engaged (purely mechanically) using the selector lever and blocks the pinion shaft via a catch, which engages in the tothing of the parking-lock gear. The final drive is blocked in this way.

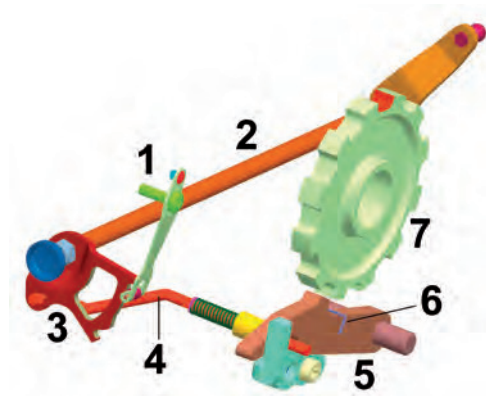

- 1 Detent spring
- 2 Selector shaft
- 3 Detent disc
- 4 Connecting rod
- 5 Catch
- 6 Leg spring
- 7 Parking-lock gear

Notes:

Power Flow

The torques are transferred either via clutch 1 or 2. Clutch 1 drives input shaft 1 (inner input shaft) and clutch 2 drives input shaft 2 (outer input shaft). Gears 1, 3, 5, 7 and reverse are on input shaft 1, while gears 2, 4 and 6 are on input shaft 2.

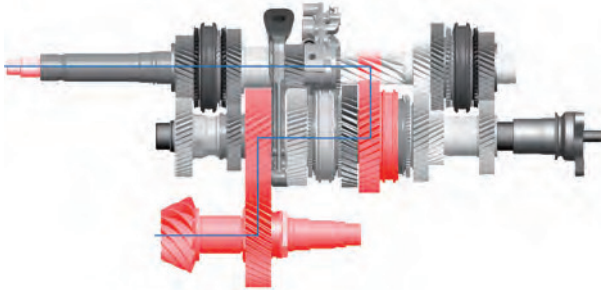

Power flow for 1st gear

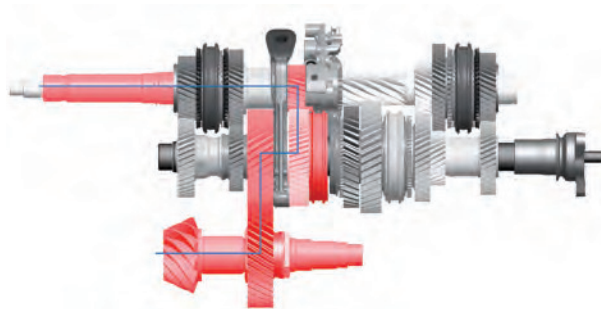

Power flow for 2nd gear

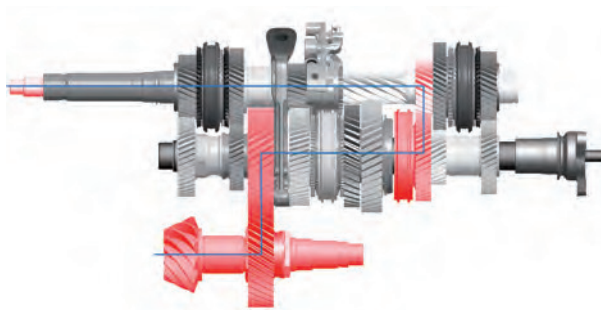

Power flow for 3rd gear

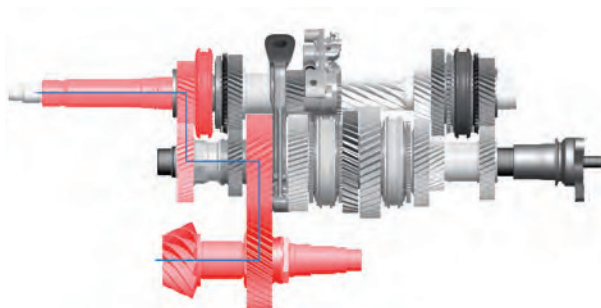

Power flow for 4th gear

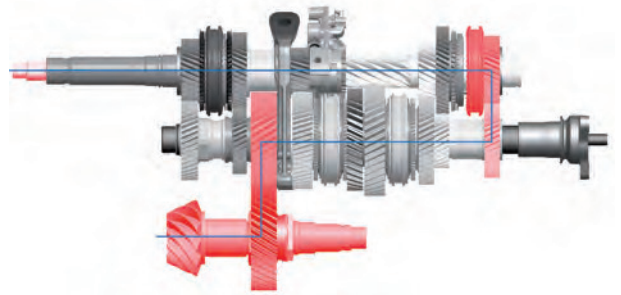

Power flow for 5th gear

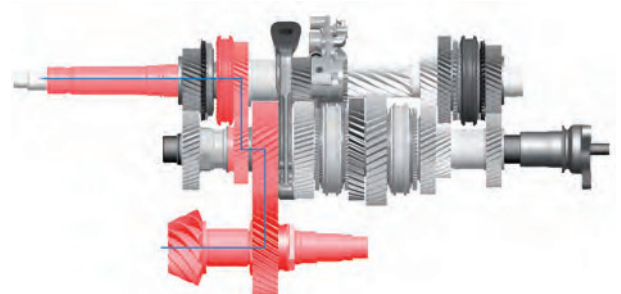

Power flow for 6th gear

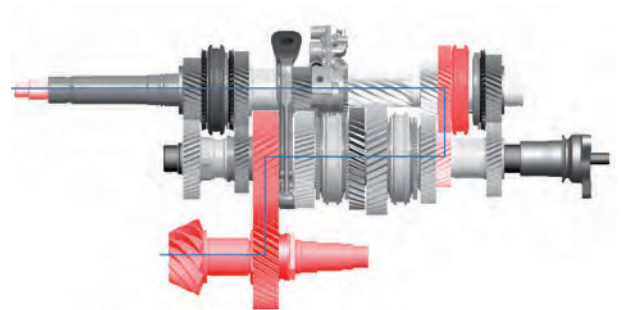

Power flow for 7th gear

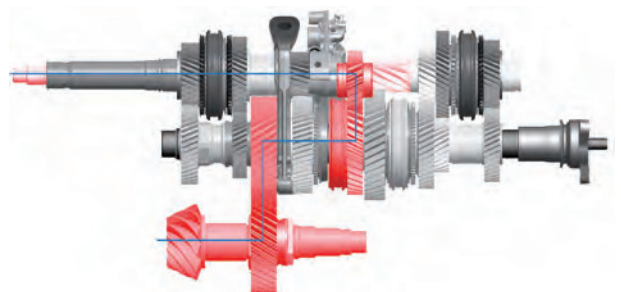

Power flow for reverse gear

PDK Transmission

Dual-mass Flywheel

The engine torque is routed into the clutches via a dual-mass flywheel.

Doppelkupplung

The wet dual clutch or Doppelkupplung is a central module of the PDK transmission. With its wide range of technical features, it meets the functional requirements of the transmission control system, thereby shaping the special character of this transmission concept. Very fast response times, low inertia and good, comfortable friction values, combined with good economic viability allow both very sporty driving with highly dynamic gear changing as well as comfortable cruising. For safety reasons, the clutches are opened when they are depressurized and inactive. The radial arrangement of the disc packs provides the best combination from the point of view of performance and space.

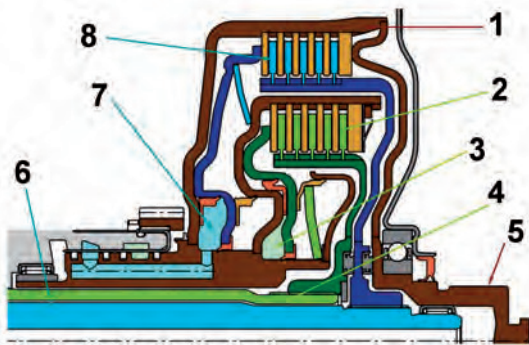

- 1 Outer disc carrier (engine speed)
- 2 Disc pack, transmission 2
- 3 Hydraulic actuation, transmission 2
- 4 Input shaft, transmission 2
- 5 Connection to engine
- 6 Input shaft, transmission 1
- 7 Hydraulic actuation, transmission 1
- 8 Disc pack for transmission 1

Careful selection of pad type, pad dimensions and usage as well as uniform distribution of thermal load and oil flow in the disc pack, along with the corresponding oil types, are prerequisites for comfort and performance over the service life. Low drag torques even at low temperatures as well as good resistance at high speeds guarantee comfort and excellent sportiness, but are also important safety requirements.

Function

The Doppelkupplung is positioned directly on the transmission input. It transfers the engine torque from the dual-mass flywheel via the profile of its input shaft and passes it through the housing cover of the dry chamber into the wet chamber and on to the clutch primary.

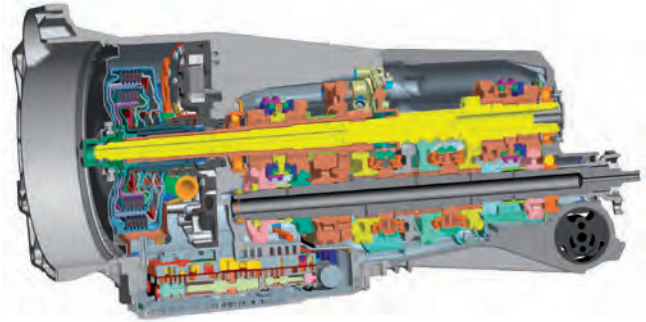

The disc packs are arranged radially over each other. The clutch sends the torque either to the odd gears 1st, 3rd, 5th and 7th and to reverse gear via the outer disc pack, or to the transmission with 2nd, 4th and 6th gear via the inner disc pack, depending on which of the two is activated by the control pressure of the hydraulic transmission control system. The torque is routed into the two transmissions via the profiles of the transmission input shafts.

Special hydraulic oil is used for actuating the Doppelkupplung hydraulically and for cooling the clutch. This oil is also used for shifting gears. PDK has a separate oil circuit for lubricating the gear wheel set and for cooling. This oil must not be mixed with hydraulic oil.

Both clutches can be actuated and operated with slip regulation independently of each other. Both clutches display slight centrifugal force overcompensation. The Doppelkupplung is not fully slip-regulated in any operating state, which means that the vehicle must be held with the brake when in gear to prevent it from rolling away.

Clutch Cooling

The clutches are cooled with a separate oil flow to prevent them from overheating. Clutch cooling and clutch control are activated at the same time. The cooling oil flow is regulated by a control valve on the hydraulic control unit.

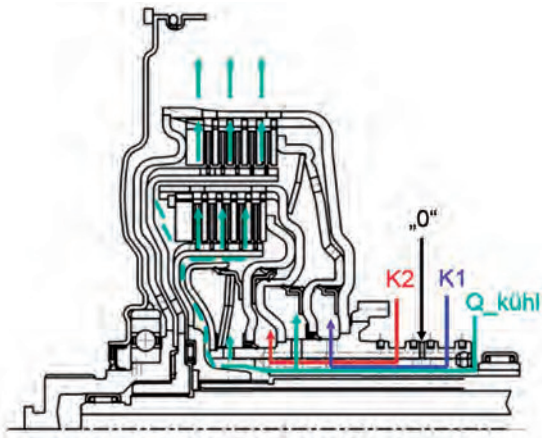

- K1 Cooling duct for clutch 1
- K2 Cooling duct for clutch 2
- Q_kühl Cooling duct cross-section (regulated)
- "0" Cooling duct closed

Hydraulic Control

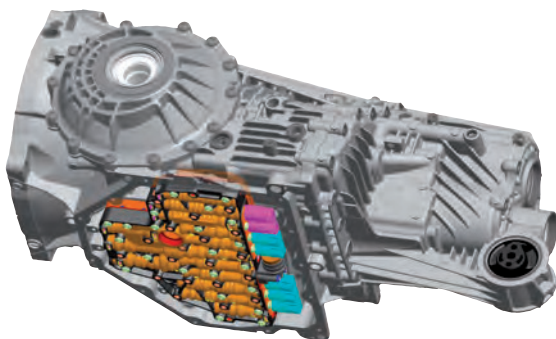

The hydraulic switching device performs the following tasks:

- Controls the system and reducing pressure
- Supplies oil to the actuators, clutches, actuating cylinders, cooling system and lubrication system
- Activates the clutches and actuating cylinders
- Provides emergency hold functions during mechanical transmission emergency operation
- Controls the parking lock hydraulically

The hydraulic system is installed in the oil pan area in the transmission.

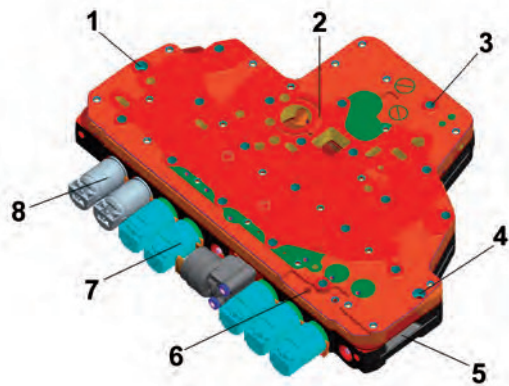

- 1 Centering bore B
- 2 Locking groove
- 3 Pass-through screws, 20 ea.
- 4 Centering bore
- 5 Tension point
- 6 Oil discharge for temperature sensor
- 7 Pressure regulator
- 8 Solenoid valves

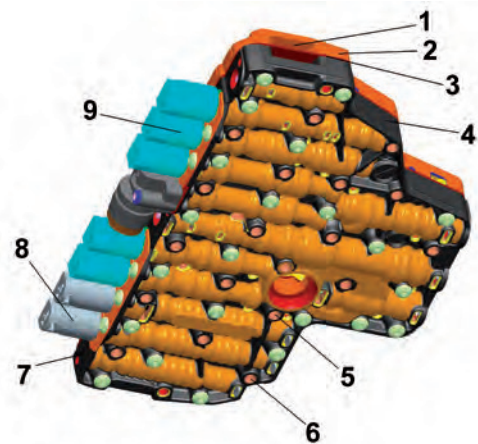

- 1 Tension point
- 2 Port plate
- 3 Intermediate plate
- 4 Valve housing
- 5 Bolts in hydraulic switching device, 22 x M6
- 6 Through bolts, 20 x M6
- 7 Retaining bracket
- 8 Solenoid valves
- 9 Pressure regulator

PDK Transmission

Hydraulic Control (cont'd)

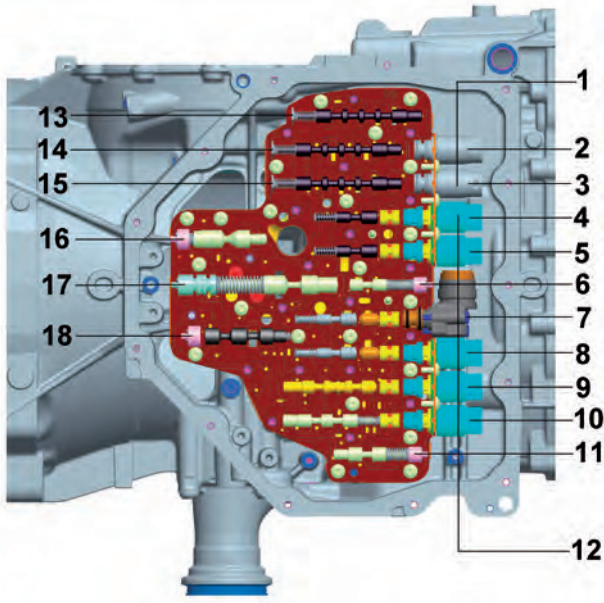

- 1 Solenoid valves, 2 ea.
- 2 Solenoid valve 1
- 3 Solenoid valve 2
- 4 Gear valve 2, EDS5
- 5 Gear valve 1, EDS6
- 6 Pressure-reducing valve
- 7 Clutch valve 1, EDS1
- 8 Clutch valve 2, EDS2
- 9 Clutch selector valve, EDS3
- 10 Pressure control valve, EDS3
- 11 Switch-over valve
- 12 Pressure regulator, 6 ea.
- 13 Cooling valve
- 14 System-pressure valve
- 15 Pressure control valve (cooler)
- 16 Cylinder selection valve 1
- 17 Transmission selection valve
- 18 Cylinder selection valve 2

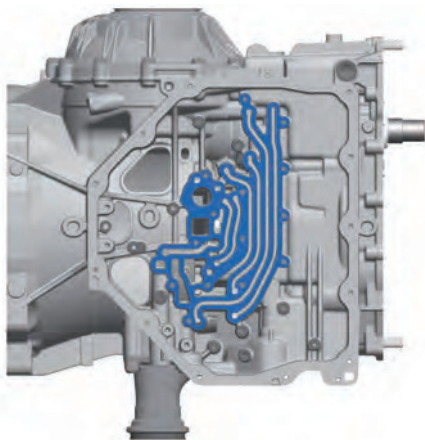

Oil Cooler

The oil cooler (1) is fitted on the outside of the transmission. It cools the clutch fluid and hydraulic oil, which is heated up significantly more than gear-wheel oil as a result of operating the clutch (frictional heat).

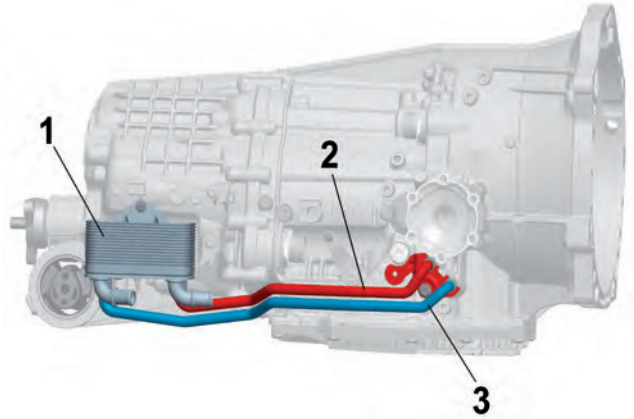

- 1 Oil cooler (oil/water heat exchanger)
- 2 Cooler supply line
- 3 Cooler return line

The top pipeline (2) is the cooler supply line, while the bottom pipeline (3) is the cooler return line.

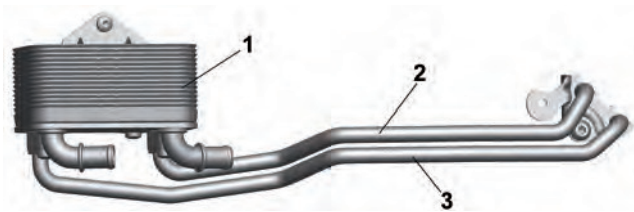

The gear-wheel oil is cooled sufficiently by the transmission housing.

Sensors

The following sensors are used in the transmission for recording speed, temperature, pressure and distance signals.

- 4 distance sensors (combined in one housing)
- 2 rpm or speed sensors (combined in one housing)
- 2 pressure sensors
- 1 temperature sensor

The distance and speed sensors are connected by a wire harness and are guided outward via the 16-pin transmission connector.

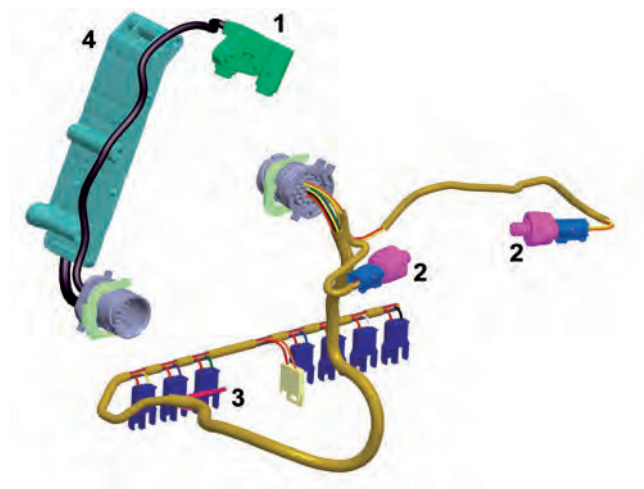

- 1 Speed sensors
- 2 Pressure sensors
- 3 Temperature sensor
- 4 Distance sensors

The transmission has two separate wire harnesses due to the design with two chambers with different fluids. A 16 pin harness is installed in the section with gear lube (Mobilube PTX Formula A SAE 75W – 90) and a 20 pin harness in the section with hydraulic oil (Pentosin Gear Oil FFL3).

Notes:

The pressure sensors (2) are connected to the wire harness, to which the solenoid valves and pressure adjusters are connected. The temperature sensor (3) is connected permanently to the wire harness. This is guided out of the transmission via a 20-pin connector. The sensors are all located in the transmission. Sensors cannot be removed or installed from outside.

Distance Sensors

The distance sensor unit (also called “sensor tower”) is used for recording the position of each individual shift rod (1). It is designed as an assembly, made up of 4 integrated absolute distance sensors.

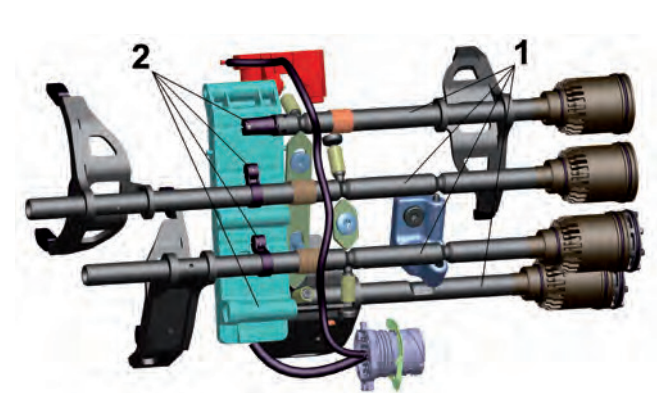

Each shift rod (1) is assigned a sensor, which converts the linear movement of the shift rod into a distance-proportional PWM signal. Other functional components of the distance sensor unit include four associated sensor magnets (2) on the shift rods. The supply voltage for the distance sensors is 5 V.

The diagnostic system checks the sensor as follows:

- Short circuit to ground
- Short circuit to supply voltage
- Open circuit in line
- Signal plausibility

PDK Transmission

Speed Sensors

The speed sensors (1) record the transmission input speeds and rotation directions for input shaft 1 and 2. They are designed as an assembly made up of two individual speed sensors in one housing. The pickup or sensor wheel (2) records the speed of input shaft 1, while the fixed gear wheel for 2nd gear records the speed of input shaft 2. A coded PWM signal is generated as the output signal.

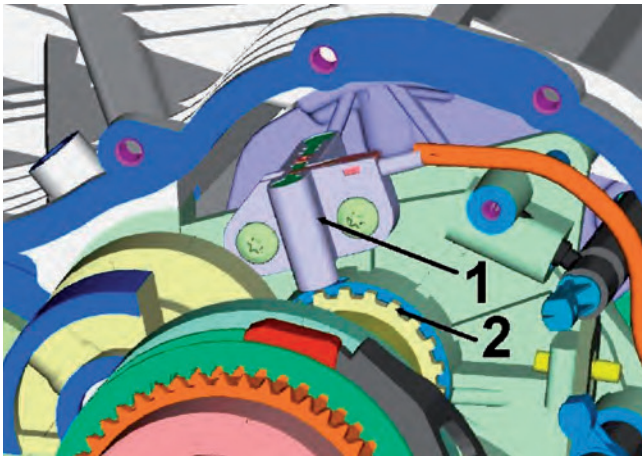

The supply voltage for the speed sensors is 8.5 V.

The diagnostic system checks the sensor as follows:

- Short circuit to ground
- Short circuit to supply voltage
- Open circuit in line
- Signal plausibility

Pressure Sensors

The two pressure sensors (1) for measuring the clutch pressure values of the two Doppelkupplung clutches are read directly at the rotary transmission feed-through point.

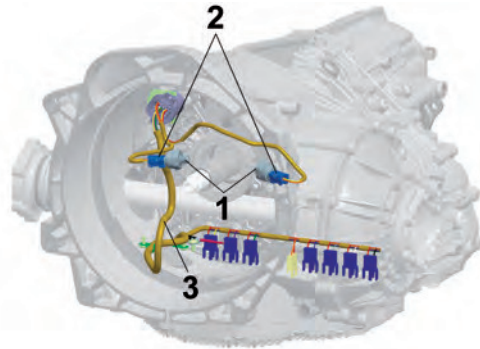

They are fitted in the centering plate and are connected to the wire harness (3) by connectors (2). The supply voltage is 5 V.

The diagnostic system checks the sensor as follows:

- Short circuit to ground
- Short circuit to supply voltage
- Open circuit in line
- Signal plausibility

Temperature Sensor

The temperature sensor is used to record the sump temperature of the hydraulic oil. This involves measuring a temperature-dependent resistance.

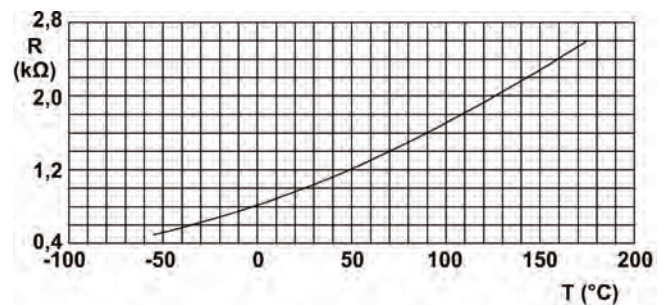

The supply voltage is 5 V.

The diagnostic system checks the sensor as follows:

- Short circuit to ground
- Short circuit to supply voltage
- Open circuit in line
- Signal plausibility

Electronic Transmission Control

The transmission control unit is connected to other control units in the vehicle via the CAN bus.

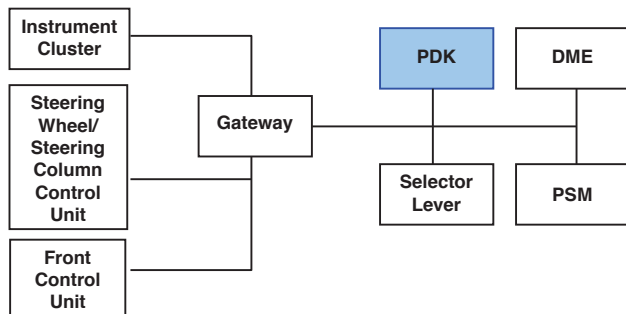

Interfaces in the Control Unit Network

The control unit receives information about the driver request, which includes the following:

- Selector-lever position
- Sport button and/or Sport Plus button
- Accelerator pedal position
- Brake signal

In addition, the operating state of the vehicle is also included:

- Wheel speeds
- Vehicle speed
- Road resistance
- Axial and lateral acceleration
- Altitude factor
- Engine and transmission speed
- Engine and transmission temperature

These input values are processed in the driving software and the driver request is executed, depending on the shift program and driver type detection.

Control Unit Location

911 Carrera (997) – The transmission control unit is located at the left behind the door in the sill area.

Boxster/Cayman (987) – The transmission control unit is located in the rear right of the luggage compartment beneath the cover.

PDK Shift-Lever

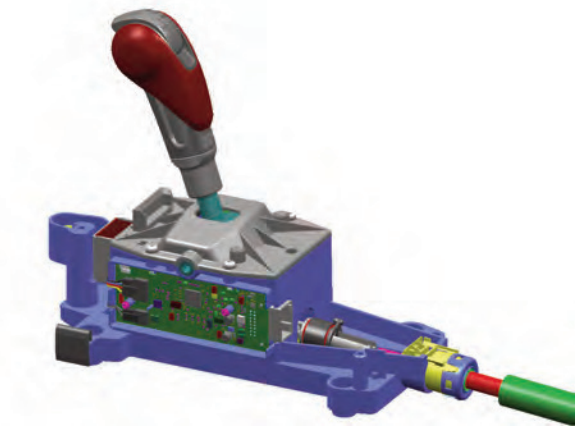

The new PDK Selector lever is a shift by wire concept (There is no mechanical connection between the shift lever and the transmission with the exception of the mechanical park lock.)

The PDK selector lever has 2 microcontrollers and 2 Hall sensors to detect the lever position (redundant position sensing). The main communications interface is by CAN drive train bus with the serial bus as a redundant function. The Selector lever lock for key and shiftlock is controlled by the PDK control unit.

PDK Transmission

PDK Shift-Lever Interface

Engine off:

Serial line is used for communication (gear position from instrument cluster).

Engine running:

CAN bus is utilized for communication.

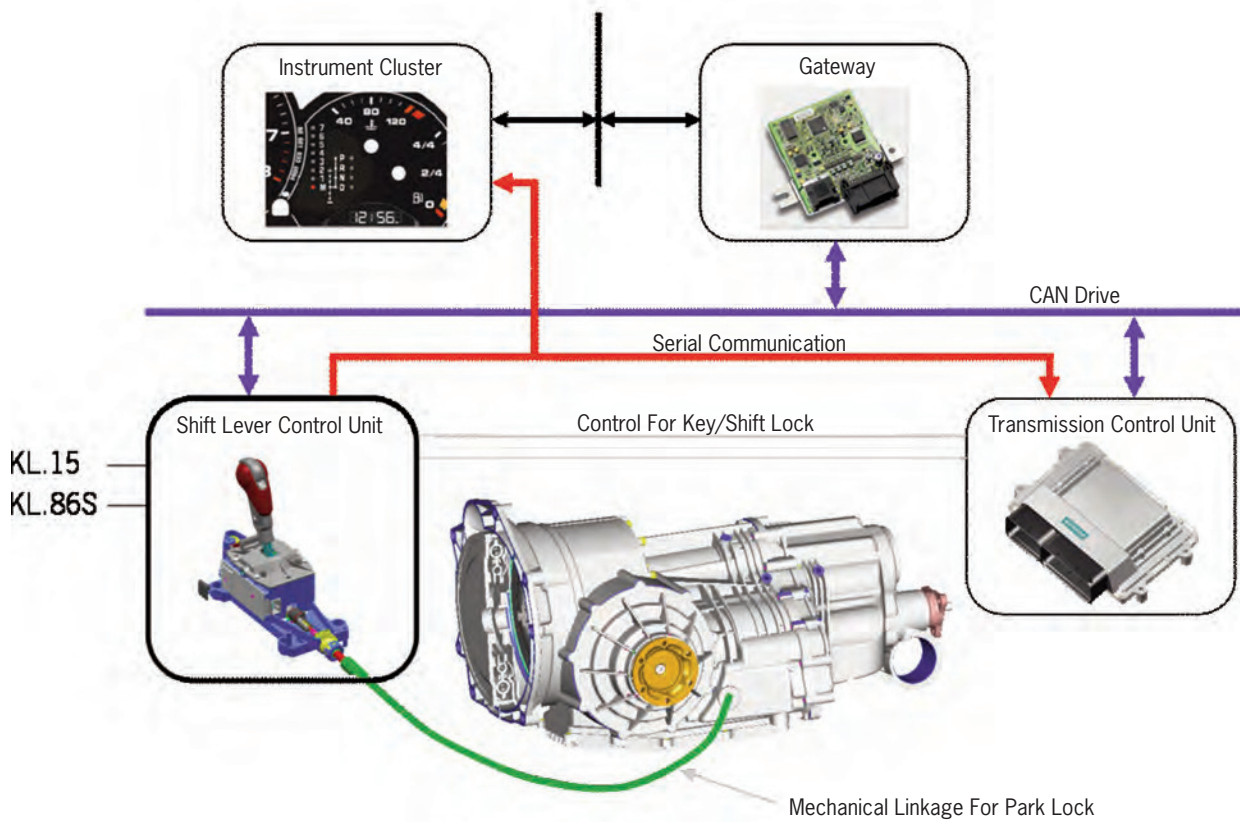

Notes:
