

Exhaust System/Sport Exhaust System (I-no. XLF)



Information

This bulletin replaces bulletin Group 2, #5/05, dated April 11, 2007.

Concern: **Retrofitting**

Model Year: **As of 2005 up to 2008**

Engine Types: M96/05 = 3.6 ltr. and M97/01 = 3.8 ltr.

Restriction: **Not** approved for vehicles with power kit (I-no. X51).

Information: In the new sport exhaust system, the signal for activating the flaps in the rear mufflers does not come from the vehicle speedometer as before, but from the respective current map in the DME control unit. This depends on the driving status and the accelerator pedal position among other things.

Sport exhaust system control:

- Vehicles with Sport Chrono package (I-nos. 639/640): → Switch console with “Sport” button (see Owner’s Manual for the vehicle)
- Vehicles without Sport Chrono package: → New switch console with additional “Double tailpipe” button

The regulating time after pressing the button, determined by the response time of the pneumatics, is approx. 1 - 2 seconds.

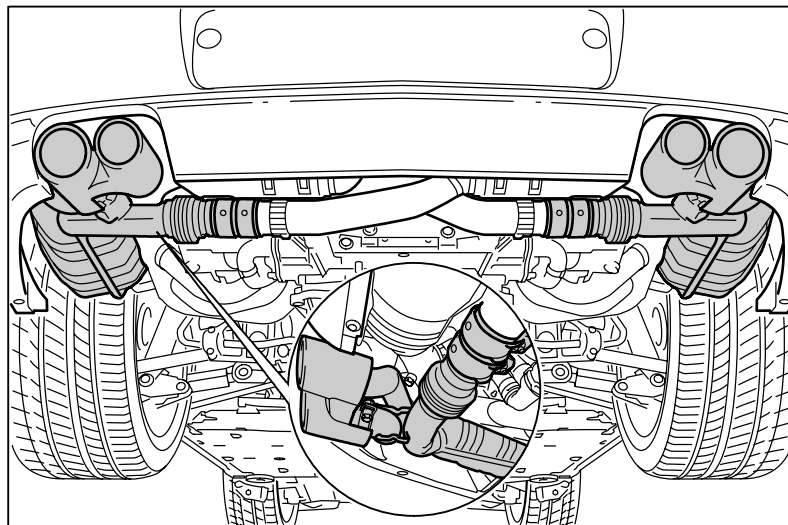

Figure 1

Engine power and exhaust behavior of the vehicle are not affected. The sport exhaust system is also available ex-works for new vehicles under Exclusive option No. "XLF"!

In the "Double tailpipe" button, the display (diode lights up) for the activated (clearly perceptible exhaust motor noise) or deactivated sport exhaust system has been changed as follows as of model year '06.

Model year '05:

Diode lights up in "Sport" button: sports exhaust system is active.

Diode lights up in the "Double tailpipe" button: sports exhaust system is not active.

The diode also flashes in the "Double tailpipe" button to indicate the regulating status of the flaps in the rear mufflers.

As of model year '06:

Diode lights up in the "Sport" (I-nos. 639/640) and "Double tailpipe" buttons: sport exhaust system is active.

Parts Info: **997.044.200.02** ⇒ Sport exhaust system, complete

Only for vehicles without Sport Chrono package (I-nos. 639/640):

997.613.129.00 FMH ⇒ Sport exhaust system button → Vehicles without Porsche Active Suspension Management (PASM – I-no. 475)

997.613.131.00 FMH ⇒ Sport exhaust system button → Vehicles with I-no. 475

Parts List:

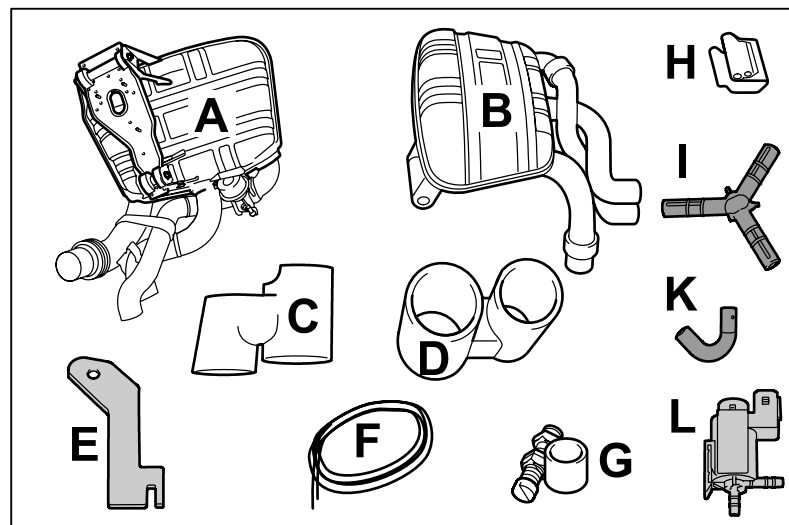

Figure 2

997.111.611.02 1 x ⇒ Rear muffler, right complete (for cylinder bank 1–3); ⇒ Figure 2

-A-

997.111.612.02 1 x ⇒ Rear muffler, left complete (for cylinder bank 4–6); ⇒ Figure 2

-B-

	997.111.982.20	1 x	⇒ Tailpipe, left (for cylinder bank 4–6); ⇒ <i>Figure 2 -C-</i>
	997.111.981.20	1 x	⇒ Tailpipe, right (for cylinder bank 1–3); ⇒ <i>Figure 2 -D-</i>
	996.111.989.00	1 x	⇒ Change-over valve holder; ⇒ <i>Figure 2 -E-</i>
	999.181.295.40	2 x	⇒ Hose (steel-armoured); approx. 700 mm long ⇒ <i>Figure 2 -F-</i>
	999.512.361.02	4 x	⇒ Hose clamp; clamping range 6 mm; width 7 mm ⇒ <i>Figure 2 -G-</i>
	999.591.746.02	4 x	⇒ Hose clip, 7.0 - 9.0 ⇒ <i>Figure 2 -H-</i>
	928.573.727.03	2 x	⇒ Branch piece, 3-way (Y piece) ⇒ <i>Figure 2 -I-</i>
	928.574.717.03	1 x	⇒ Protective tube, bent ⇒ <i>Figure 2 -K-</i>
	997.612.905.01	1 x	⇒ Electrical system materials, consisting of: 4 x wire harnesses, 1 x change-over valve ⇒ <i>Figure 2 -L-</i> and 12 x tie-wraps (not shown)
	997.111.520.00	2 x	⇒ Clamping sleeve (not shown)
	900.380.005.09	10 x	⇒ M8 nut, self-locking (not shown)
	— — —	2 x	⇒ Tie-wrap, 3.5 x 75 mm (not shown)
	999.181.374.40	1 x	⇒ Line (Tekalan) 4 x 1 x 250 (not shown)
	999.181.424.40	1 x	⇒ Line (Tekalan) 4 x 1 x 800 (not shown)
	999.181.401.40	1 x	⇒ Line (Tekalan) 4 x 1 x 580 (not shown)
Spare Parts:	996.605.123.01	1 x	⇒ Electric change-over valve ⇒ <i>Figure 2 -L-</i>
Materials:	000.043.204.82	1 x	⇒ Adhesive compound
	— — —	1 x	Commercially available rust solvent, e.g. WD40
	— — —	1 x	Wrapping tape
	— — —	2 x	Auxiliary line (Tekalan or Teflon hose) approx. 1,500 mm long

Information: Identifying features when installed

The rear mufflers are marked on the outside as follows:
Left rear muffler (for cylinder bank 4–6): Porsche logo;
code 997/20 and Part No.: 997.111.612.02 (⇒ *Figure 3 -bottom inset-*);

Right rear muffler (for cylinder bank 1–3): Porsche logo;
code 997/19 and Part No.: 997.111.611.02.

Both identification codes can be read using a mirror, for example.

Left tailpipe: Porsche logo and Part No.:
997.111.982.20 (⇒ *Figure 3 -top inset-*);

Right tailpipe: Porsche logo and Part No.:
997.111.981.20.

Please also provide your sales department with this information and give the customer a copy of the first three pages of this Technical Information.

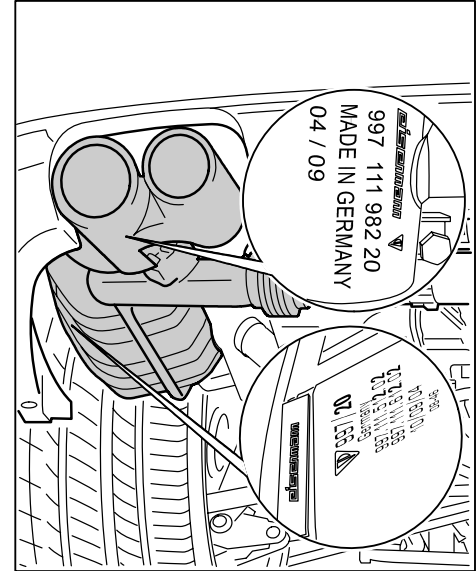

Figure 3

Tools:	Socket-wrench insert a/f 4/5/6/7/10/13/17	Torx wrench insert T20/T30
	Slotted and Phillips screwdrivers	Plastic wedge
	Internal polygon wrench, a/f 8	PWIS Tester 9718
	Shop light	Hot-air gun
	Press-out and unlocking tools for flat and round plug connections of every size Nr.155	
	Repair kit for wire harnesses Nr.155-1	

Work Procedure: 1 Preparatory work

- 1.1 Drive vehicle onto the lifting platform.
- 1.2 Disconnect the battery ⇒ *Workshop Manual '2706IN Work instructions after disconnecting the battery'* and raise the vehicle ⇒ *Workshop Manual '400000 Lifting the vehicle'*.

⚠ CAUTION

Hot components

- **Risk of burns**
- ⇒ **Let hot components cool down.**
- ⇒ **Wear personal protective gear.**

- 1.3 Remove both rear mufflers and exhaust tailpipes. ⇒ *Workshop Manual '263319 Removing and installing rear silencer - section on "Removing"*
- 1.4 Get the two new rear silencers for the sport exhaust system ready for installation.
The description here relates only to the right rear muffler!

- 1.4.1 Remove stop-chock holder (⇒ *Figure 4 -A-*) from the old rear muffler and fit it on the new rear muffler using new M8 nuts (2 x 900.380.005.09).

Tightening torque: 23 Nm (17 ftlb.)

- 1.4.2 Clip in hose clip (1 x 999.591.746.02; ⇒ *Figure 4 -B-*) on the web plate bearing (small) of the stop-chock holder (see Inset, ⇒ *Figure 4*).

- 1.4.3 Connect hose (1 x 999.181.295.40; ⇒ *Figure 4 -C-*) to the connection nipple on the vacuum unit and secure with a hose clamp (1 x 999.512.361.02; ⇒ *Figure 4 -D-*).

- 1.4.4 Clip hose (999.181.295.40; ⇒ *Figure 4 -C-*) into the hose clip (999.591.746.02; ⇒ *Figure 4 -B-*) on the web plate bearing (small).

- 1.4.5 **ONLY** for right rear muffler (997.111.611.02):
Insert line (1 x 999.181.374.40; ⇒ *Figure 4 -E-*) at least 15 mm into the hose (999.181.295.40).

- 1.4.6 **ONLY** for left rear muffler (997.111.612.02):
Insert line (999.181.424.40) at least 15 mm into the hose (999.181.295.40).

- 1.4.7 Secure hose (⇒ *Figure 4 -C-*) and line (⇒ *Figure 4 -E-*) with a hose clamp (⇒ *Figure 4 -F-*).

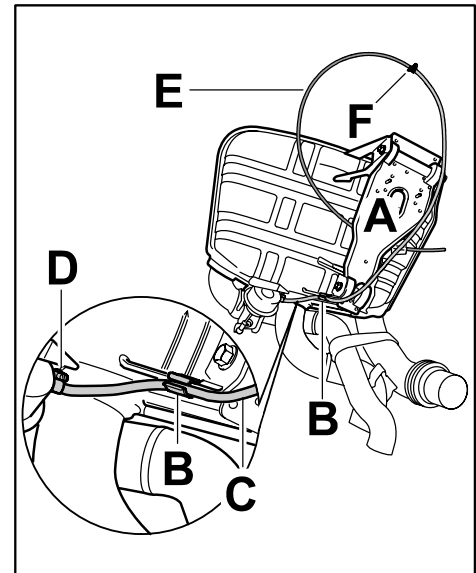

Figure 4

- 1.5 Clip hose clip (999.591.746.02) in at the top of both rear muffler holders at the engine side (right side of engine [cylinder bank 4–6], see ⇒ *Figure 5 -A-*).
- 1.6 Lower the vehicle and open engine compartment lid.
- 1.7 Remove air cleaner housing completely ⇒ *Workshop Manual '242519 Removing and installing air cleaner housing - section on "Removing"*.

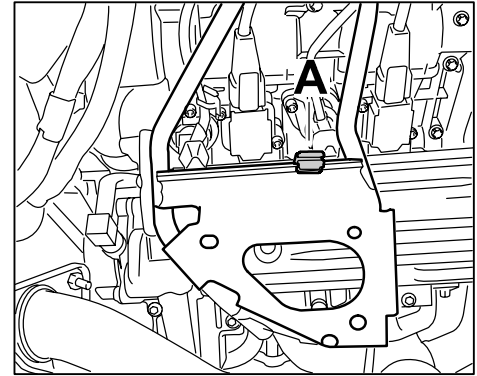

Figure 5

- 2 Install electric change-over valve.
 - 2.1 Clip in holder (996.111.989.00; ⇒ *Figure 6 -A-*) at the change-over valve (996.605.123.01; ⇒ *Figure 6 -B-*).
 - 2.2 Connect Y-piece (1 x 928.573.727.03; ⇒ *Figure 6 -C-*) and bent protective tube (928.574.717.03; ⇒ *Figure 6 -D-*) to the change-over valve as required.
 - 2.3 Remove hexagon-head bolt for Pentosin reservoir support from intake distributor for cylinders 4–6.

**Information**

Observe installation position of electric switch-over valve!

For vertical installation, the 2-pin connector for the switch-over valve can no longer be plugged in or becomes chafed at the body.

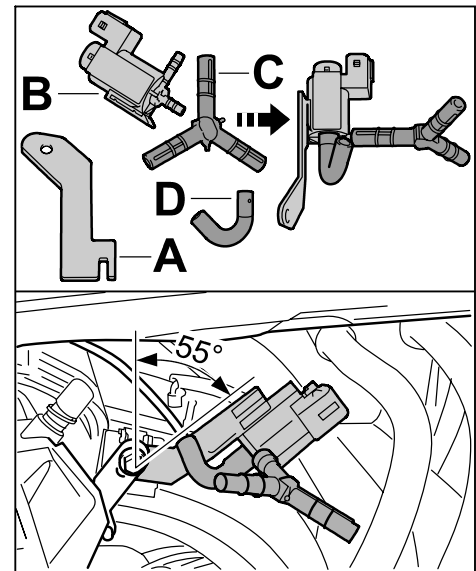

Figure 6

- 2.4 Position holder with change-over valve at an angle of approx. 55° and fit it and the reservoir support on the intake distributor for cylinders 4-6 (⇒ *Figure 6 -bottom-*).
Tightening torque: 9.7 Nm (7.5 ftlb.)

- 3 Install the two new rear mufflers for the sport exhaust system and the exhaust tailpipes.

- 3.1 Route auxiliary lines for installing rear mufflers.



Information

Auxiliary lines (Tekalan or Teflon) are used as an aid for routing the lines from the vacuum unit (rear muffler) to the electric switch-over valve. Route auxiliary lines as follows:

- 3.1.1 Auxiliary line (⇒ *Figure 7 -A-*) for right rear muffler (997.111.611.00):

Underneath filler neck for hydraulic oil → above air conditioning compressor → underneath fuel collection pipe (cylinders 4–6) → between intake pipe adapters for cylinders 4 and 5 → rear muffler holder, right.

- 3.1.2 Auxiliary line for left rear muffler (997.111.612.00):

Underneath filler neck for hydraulic oil → underneath throttle housing (electronic throttle adjuster) → intake air distributors for cylinders 1–3 → rear muffler holder, left.

- 3.2 Lift the vehicle and position new clamping sleeves (2 x 997.111.520.00) on the catalytic converters.
- 3.3 Position the two new rear mufflers (997.111.611.02/997.111.612.02) under the vehicle at the right or left according to their installation position.
- 3.4 Secure auxiliary lines that are hanging down to the rear muffler vacuum lines with adhesive tape, for example.

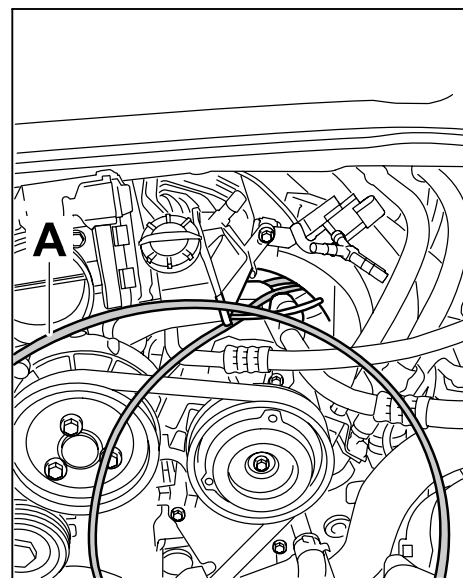

Figure 7

- 3.5 Position rear muffler on the rear muffler holder at the engine side (⇒ *Figure 8 -A-*) with the help of a second person, who must pull the auxiliary lines into the engine compartment at the same time, and pre-fit loosely using new M8 nuts (3 x 900.380.005.09).

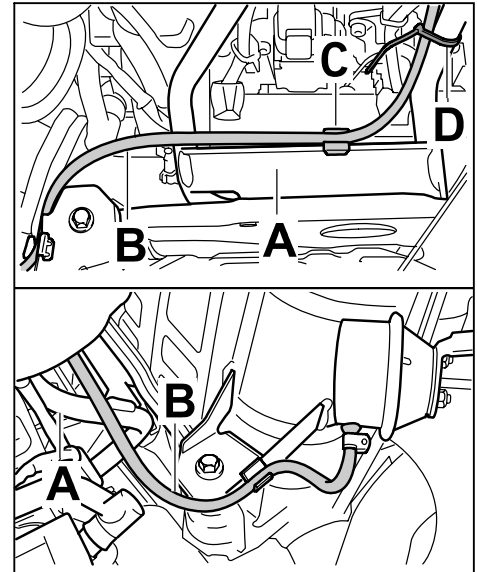

Figure 8

CAUTION

Risk of damage to lines and/or hoses (vacuum)

- **due to incorrect routing.**
- ⇒ **Maintain a sufficient distance from components exposed to high temperatures while driving.**
- ⇒ **Avoid making tight bends.**

- 3.6 Clip hose (999.181.295.40; ⇒ *Figure 8 -B-*) into the hose clip (999.591.746.02; ⇒ *Figure 8 -C-*) and secure it to the rear muffler holder at the engine side using a tie-wrap (⇒ *Figure 8 -D-*).
- 3.7 Fully tighten rear muffler on the holder at the engine side.
Tightening torque: 23 Nm (17 ftlb.)
- 3.8 Tighten clamping sleeves for rear muffler/catalytic converter.
Tightening torque: 23 Nm (17 ftlb.)
- 3.9 Fit the two new exhaust tailpipes (997.111.981.20/997.111.982.20).
- 3.9.1 Loosen M8 hexagon-head bolt on the exhaust tailpipes.
- 3.9.2 Fit exhaust tailpipe onto the exhaust pipes of the relevant silencer.
- 3.9.3 Tighten clamp on exhaust tailpipe hand-tight and align the exhaust tailpipe with the cut-out in the rear apron.
- 3.9.4 Tighten clamp on the exhaust tailpipe fully.
Tightening torque: 30 Nm (22 ftlb.)

- 4 Route and connect remaining lines (Tekalan).
 - 4.1 Guide lines of both rear mufflers to the Y-piece on the electric change-over valve.
 - 4.2 Mark the length you need plus 10–20 mm on the lines and shorten lines if necessary.
 - 4.3 Insert lines at least 10 mm into the free connection nipples of the Y-piece.



Information

Figure 9, Item A shows the standard routing.

- 4.4 Pull line (Tekalan, ⇒ *Figure 9 -A1-*) for the electric change-over valve (resonance tube) with the protective tube (⇒ *Figure 9 -A2-*) until it emerges out of the T-piece (⇒ *Figure 9 -A3-*; vacuum pump line for engine/brake booster).
- 4.5 Replace protective tube with Y-piece and insert it into the T-piece of the vacuum pump line for the engine/brake booster in such a way that one connection nipple is facing forwards (in direction of travel) and one connection nipple is facing backwards.
- 4.6 Push vacuum pump line for engine/brake booster at least 10 mm into the forward-facing connection nipple of the Y-piece.
- 4.7 Slide line (999.181.401.40) at least 10 mm into the rear-facing connection nipple (⇒ *Figure 9 -B-*) and route it to the electric change-over valve as follows:
Intake distributor (cylinders 1–3) → underneath throttle valve (electronic throttle adjuster) → underneath Pentosin reservoir → protective tube on electric change-over valve (⇒ *Figure 9 -C-*).

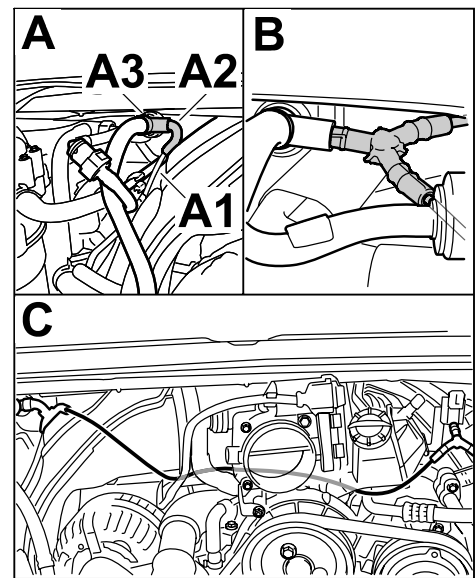

Figure 9



Risk of short circuit and fire

- **due to work on the vehicle electrical system.**
- ⇒ **When working on the electrical system, the battery must always be disconnected and covered.**
- ⇒ **Always route the electrical wires without tension and so that no chafing occurs and secure to existing wires/components with tie-wraps/electrical tape.**

- 5 Route electric line for change-over valve to DME control unit and connect it.

- 5.1 Preparatory work.
- 5.1.1 **ONLY** for vehicles with Bose Surround sound system (I-no. 680):
Remove subwoofer ⇒ *Workshop Manual '913619 Removing and installing subwoofer - section on "Removing"*.
- 5.1.2 Remove rear side trim panels ⇒ *Workshop Manual '707519 Removing and installing rear side trim panel - section on "Removing"*.
- 5.1.3 Remove belt fittings for rear three-point belts ⇒ *Workshop Manual '691219 Removing and installing rear three-point belt - section on "Removing"* and rear seat-belt buckles ⇒ *Workshop Manual '692519 Removing and installing rear seat-belt buckle - section on "Removing"*.
- 5.1.4 Expose DME control unit ⇒ *Workshop Manual '247019 Removing and installing DME control unit – section on "Removing"*.

- 5.2 Route electric wire harness from change-over valve to the DME control unit.

- 5.2.1 Connect 2-pin plug connection (⇒ *Figure 10 -A-*) to electric change-over valve and clip in cable clip (⇒ *Figure 10 -B-*) on refrigerant line flange.
- 5.2.2 Make a hole in the grommet (⇒ *Figure 10 -inset-*) in the passenger compartment end plate (right engine compartment).
- 5.2.3 Secure end of electric wire harness (with 2-pin connector) to an auxiliary line (Teflon or Tekalan) using adhesive tape.
- 5.2.4 Route electric wire harness (⇒ *Figure 10 -C-*) from the engine compartment through the grommet into the passenger compartment to the DME control unit.

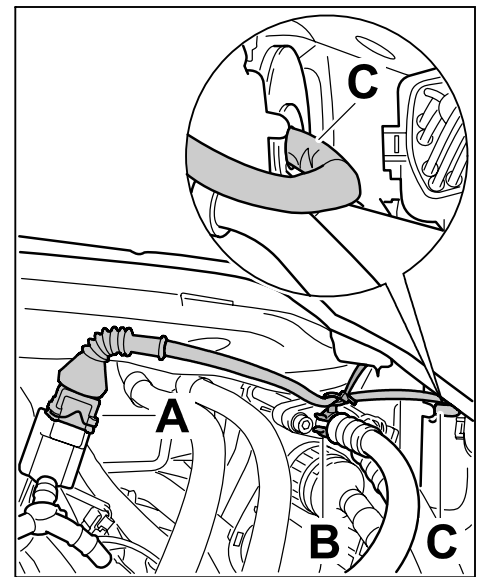

Figure 10

- 5.3 Connect electric wire harness.
 - 5.3.1 Release connectors A and C for the DME control unit.
 - 5.3.2 Insert line 5625 (MY '05) or 5631 (as of MY '06); GY/GN; 0.5² into connector C; chamber 14 (sport exhaust system valve).
 - 5.3.3 Cut off existing line 5359; RD/BU; 1.0² in connector A; chamber 8 (terminal 87) approx. 5 cm behind connector A.

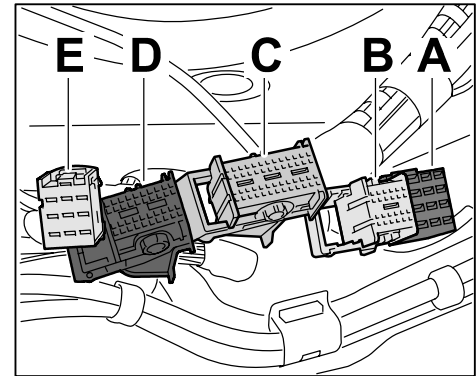

Figure 11

Strip the ends of both lines 5359; RD/BU; 1.0² and 9132; RD/BU; 0.5² (retrofit kit) and slide shrink-fit hose over line 5359; RD/BU; 1.0² on the connector side.

Bundle the ends of lines 5359; RD/BU; 1.0² and 9132; RD/BU; 0.5² (retrofit kit) and crimp them together as a splice with line 5359; RD/BU; 1.5² on the connector side and a cable connection.

Slide shrink-fit hose over the splice and shrink the hose to make it water-tight with a hot-air gun.

- 5.3.4 Use tie-wraps or wrapping tape to secure electric line to existing lines or components without tension and so that no chafing occurs.
- 5.3.5 Seal grommet in passenger compartment end plate with adhesive compound (000.043.204.82).

- 6 **ONLY** for vehicles without Sport Chrono package (I Nos. 639/640):
Installing switch console with "Double tailpipe" button

Button for vehicles without PASM (I-no. 475):

997.613.129.00 FMH; ⇒ Figure 12 -A-

Button for vehicles with PASM (I-no. 475):

997.613.130.00 FMH; ⇒ Figure 12 -B-

- 6.1 Preparatory work.

- 6.1.1 Remove center console cover at the left/right ⇒ *Workshop Manual '681419 Removing and installing centre console cover - section on "Removing"* and remove air-conditioning system regulator ⇒ *Workshop Manual '870219 Removing and installing air-conditioning system regulator - section on "Removing"*.

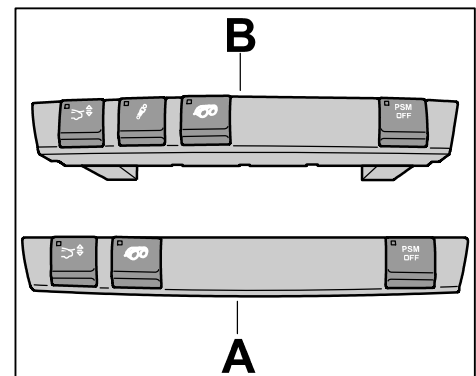

Figure 12

- 6.1.2 Remove shift-lever knob with shift-lever boot ⇒ *Workshop Manual '340419 Removing and installing shift-lever knob* – section on "Removing" and front centre console cover.
- 6.1.3 Loosen center console completely ⇒ *Workshop Manual '681719 Removing and installing centre console* - section on "Removing", but do not remove it!
- 6.1.4 Remove oddments tray ⇒ *Workshop Manual '681619 Removing and installing oddments tray* – section on "Removing" and switch console close to the center console ⇒ *Workshop Manual '962719 Removing and installing switch console* – section on "Removing".
- 6.1.5 Loosen fuse box ⇒ *Workshop Manual '978409 Loosening and securing fuse box* - section on "Loosening", and remove left inner door sill trim ⇒ *Workshop Manual '680519 Removing and installing inner door sill trim* - section on "Removing", main light switch ⇒ *Workshop Manual '940519 Removing and installing main light switch* - section on "Removing" and trim panel under dashboard ⇒ *Workshop Manual '701919 Removing and installing trim panel under dashboard* - section on "Removing".

- 6.2 Connect electric wire harness to DME control unit
ONLY for vehicles in model year '05
(⇒ *Figure 13*):

A = Connector to sport exhaust system button

X2_1 = B-pillar connection point

C = DME control unit, connector C

D = DME control unit, connector D

- 6.2.1 Insert line 9726; BU/BU; 0.5² in connector D; chamber 6 (sport exhaust system button).
- 6.2.2 Cut off existing line 5625; GY/GN; 0.5² in connector C; chamber 14 (sport exhaust system valve, see also Step 5.3.2) approx. 5 cm behind connector C.

Strip the ends of both lines 5625; GY/GN; 0.5² and 9727; GY/GN; 0.5² (retrofit kit) and slide shrink-fit hose over line 5625; GY/GN; 0.5² on the connector side.

Bundle the ends of lines 5625; GY/GN; 0.5² and 9727; GY/GN; 0.5² (retrofit kit) and crimp them together as a splice with line 5625; GY/GN; 0.5² on the connector side and a cable connection.

Slide shrink-fit hose over the splice and shrink the hose to make it water-tight with a hot-air gun.

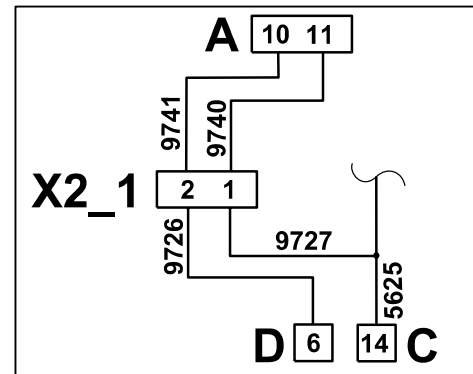

Figure 13

- 6.3 Connect electric wire harness to DME control unit
ONLY for vehicles as of model year '06
 (⇒ Figure 14):

A = Connector to sport exhaust system button

X2_1 = B-pillar connection point

D = DME control unit, connector D

- 6.3.1 Insert line 9726; BU/BU; 0.5² in connector D; chamber 6 (sport exhaust system button).

- 6.3.2 Insert line 9727; GY/GN; 0.5² in connector D; chamber 17 (diode for sport exhaust system).

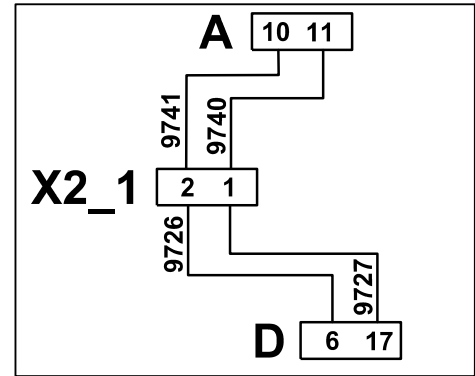

Figure 14

- 6.4 Route electric wire harness to the center console and connect it.

- 6.4.1 Wrap adhesive tape around line 9726; BU/BU; 0.5² and line 9727; GY/GN; 0.5².

- 6.4.2 Route both lines along the electric wire harness as follows:
 DME control unit (on the Coupé: see ⇒ Figure 15 -A-) → node point for rear-seat floorpan assembly → left side panel → left B-pillar (⇒ Figure 15 -B-).

- 6.4.3 Plug pin contacts of both lines into 2-pin connector as follows:
 Line 9727; GY/GN; 0.5² in chamber 1 (button LED)
 Line 9726; BU/BU; 0.5² in chamber 2 (button signal)

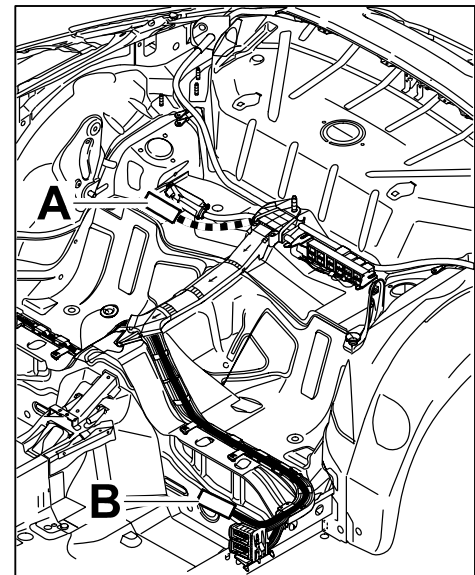

Figure 15

- 6.4.4 Connect 2-pin plug connection for connection point X2_1 (left B-pillar).

Make sure the line colours match in the plug socket and connector!

Chamber 1: GY/GN; 0.5²; lines: 9727 (connector; ⇒ Figure 16 -A-) and 9740 (plug socket; ⇒ Figure 16 -B-)

Chamber 2: BU/BU; 0.5²; lines: 9726 (connector) and 9741 (plug socket)

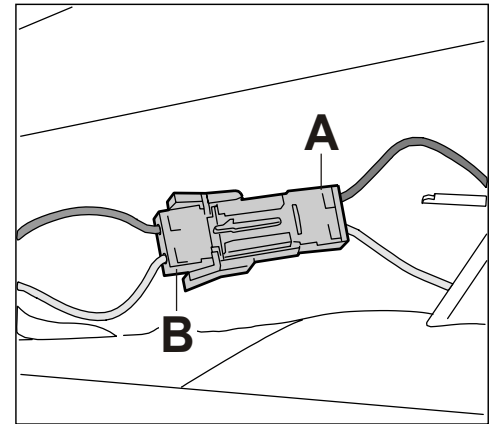

Figure 16

- 6.4.5 Route lines 9740; GY/GN; 0.5² and 9741; BU/BU; 0.5 from the B-pillar to the switch console in the center console area as follows:
Connection point X2_1 (left B-pillar) → door sill → A-pillar → underneath dashboard, above support frame (along standard wire harness) → lower slot in center console
- 6.4.6 Open secondary lock on 16-pin connector for the new switch module including “sport exhaust system” symbol and insert socket contacts of the lines (No. 9741 and No. 9740) into the 16-pin plug socket as follows:
Line 9740; GY/GN; 0.5² in chamber A11 (button LED)
Line 9741; BU/BU; 0.5² in chamber A10 (button signal)
Close secondary lock on 16-pin connector.
- 6.4.7 Use tie-wraps or wrapping tape to secure electric line to existing lines or components without tension and so that no chafing occurs.

- 6.5 Concluding work for installing sport exhaust system button

- 6.5.1 Install trim panels for both B-pillars ⇒ *Workshop Manual '706719 Removing and installing B-pillar trim – section on "Installing"*.
- 6.5.2 Install trim panel under dashboard ⇒ *Workshop Manual '701919 Removing and installing trim panel under dashboard - section on "Installing"*,
main light switch ⇒ *Workshop Manual '940519 Removing and installing main light switch - section on "Installing"*,
left inner door sill trim ⇒ *Workshop Manual '680519 Removing and installing inner door sill trim - section on "Installing"* and fuse box ⇒ *Workshop Manual '978409 Loosening and securing fuse box - section on "Securing"*.

- 6.5.3 Install new button for sport exhaust system (997.613.129.00 FMH or 997.613.130.00 FMH; depending on vehicle equipment [with or without PASM – I-no. 475]) in the center console area ⇒ *Workshop Manual '962719 Removing and installing switch console - section on "Installing"* and install oddments tray ⇒ *Workshop Manual '681619 Removing and installing oddments tray - section on "Installing"*.
 - 6.5.4 Completely install center console ⇒ *Workshop Manual '681719 Removing and installing centre console - section on "Installing"*, front center console cover and shift-lever knob with shift lever boot ⇒ *Workshop Manual '340419 Removing and installing shift-lever knob - section on "Installing"*.
 - 6.5.5 Install air-conditioning system regulator ⇒ *Workshop Manual '870219 Removing and installing air-conditioning system regulator – section on "Installing"* and center console cover at the left/right ⇒ *Workshop Manual '681419 Removing and installing centre console cover – section on "Installing"*.
- 7 Concluding work and function test.
- 7.1 Install trim panels in back seat area.
 - 7.1.1 Connect plug connections to the DME control unit, then install DME control unit and secure trim panels ⇒ *Workshop Manual '247019 Removing and installing DME control unit - section on "Installing"*.
 - 7.1.2 Install belt fittings for rear three-point belts ⇒ *Workshop Manual '691219 Removing and installing rear three-point belt - section on "Installing"* and rear seat-belt buckles ⇒ *Workshop Manual '692519 Removing and installing rear seat-belt buckle - section on "Installing"*.
Tightening torque for both: 50 ± 5 Nm (37 ± 3.5 ftlb.)
 - 7.1.3 Install rear side trim panels ⇒ *Workshop Manual '707519 Removing and installing rear side trim panel - section on "Installing"*.
 - 7.1.4 **ONLY** for vehicles with Bose Surround sound system (I-no. 680):
Install subwoofer ⇒ *Workshop Manual '913619 Removing and installing subwoofer - section on "Installing"*.
 - 7.2 Read out fault memory and erase it if necessary.
 - 7.2.1 Connect a battery charger and the PIWIS Tester 9718 to the vehicle.
 - 7.2.2 Read out the fault memories of all control units and delete any faults that are present.
 - 7.2.3 PIWIS Tester 9718 and the battery charger must now be disconnected.
 - 7.3 Carry out a function test on the “sport exhaust system”.

- 7.3.1 Start the vehicle.
Depending on the vehicle status, the “sport exhaust system” is activated for 2 to 3 seconds because there is no vacuum at the rear mufflers. The exhaust flaps are open and the exhaust motor noise can be heard clearly.
As the vacuum at the rear mufflers increases, the exhaust flaps close and the exhaust motor noise eases off. The “sport exhaust system” is not active.
- ONLY** for vehicles in model year '05:
The diode in the “Sport” button (Sport Chrono package: I Nos. 639/640) does not light up when you start the vehicle! However, the diode in the “Double tailpipe” button (sport exhaust system: I-no. XLF) lights up.
- ONLY** for vehicles as of model year '06:
The diode in both buttons (“Sport” and “Double tailpipe”) does not light up when you start the vehicle!
- 7.3.2 Press “Sport” or “Double tailpipe” button.
After a regulating phase of around 2 to 3 seconds, the exhaust flaps open and the exhaust motor noise can be heard clearly. The “sport exhaust system” is active!
- ONLY** for vehicles in model year '05:
The diode in the “Sport” button lights up!
However, the diode in the “Double tailpipe” button (sport exhaust system: I-no. XLF) does not light up! Furthermore, the diode flashes to indicate the regulating status of the flaps in the rear mufflers.
- ONLY** for vehicles as of model year '06:
The diode in both buttons (“Sport” and “Double tailpipe”) lights up!
- In any event, the correct function of the sports exhaust system can also be checked by getting a second person to perform a visual inspection of the regulating movement (linkage at the exhaust flaps).

Working Times: 26013103: Sport exhaust system (1 x) retrofitted

Labor time: **380 TU**

Includes: Removing both standard rear mufflers and installing new rear mufflers with exhaust flaps;
fitting and connecting electric change-over valve;
routing pneumatic control line for exhaust flaps.
Performing function test on sport exhaust system.

Without: Installing switch console with “Sport exhaust system” button

96272350: Switch console with Sport exhaust system button (1 x) retro-fitted

Labor time: **150 TU**

- Includes: Removing and installing switch console, routing and connecting line from switch console with "Sport exhaust system" button to DME control unit.
- Without: Function test on switch console with "Sport exhaust system" button.
Included in separate LO No.

Important Notice: Porsche Cars N.A Technical Bulletins are intended for use by professional technicians, not a "Do-it-yourselfer." They are written to inform these technicians of conditions that may occur on some vehicles, or to provide information that could assist in the proper service of a vehicle. Special tools may be required to perform certain operations identified in these bulletins. Use of tools and procedures other than those recommended in these bulletins may be detrimental to the safe operation of your vehicle. Properly trained technicians have the equipment, tools, safety instructions and know-how to do a job properly and safely. If a condition is described, do not assume that the bulletin applies to your vehicle, or that your vehicle will have that condition. See your Porsche Dealer for information on whether your vehicle may benefit from the information. Part numbers listed in these bulletins are for reference only. Always check with your authorized Porsche dealer to verify correct part numbers.

© Porsche Cars North America, Inc.

Dealership	Service Manager	_____	Shop Foreman	_____	Service Technician	_____	_____	_____	_____
Distribution	Asst. Manager	_____	Warranty Admin.	_____	Service Technician	_____	_____	_____	_____
Routing									

Dr. Ing. h.c. F. Porsche AG is the owner of numerous trademarks, both registered and unregistered, including without limitation the Porsche Crest®, Porsche®, Boxster®, Carrera®, Cayenne®, Cayman™, Panamera®, Tiptronic®, VarioCam®, PCM®, 911®, 4S®, FOUR, UNCOMPROMISED. (SM) and the model numbers and distinctive shapes of Porsche's automobiles such as, the federally registered 911 and Boxster automobiles. The third party trademarks contained herein are the properties of their respective owners. Specifications, performance standards, options, and other elements shown are subject to change without notice. Some vehicles may be shown with non-U.S. equipment. Porsche recommends seat belt usage and observance of traffic laws at all times. Printed in the USA