

15 05 15 Adjusting timing Cylinder bank 4 - 6

1. Turn engine to installation position on assembly support.
2. Remove fixing pin.
Advance crankshaft 360° clockwise until the bore 1 OT (top dead centre) in the belt pulley is aligned with the fixing bore on the crankcase. Position or fix with fixing pin (short) of special tool 9595.

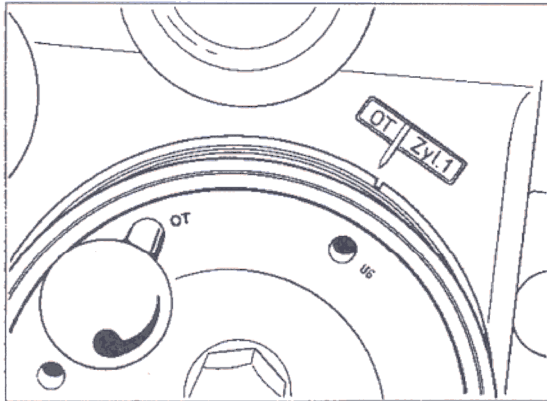

497_96

3. Check camshaft adjustment at **cylinder bank 4 - 6**:
The groove in the camshaft must face inward toward the crankcase.

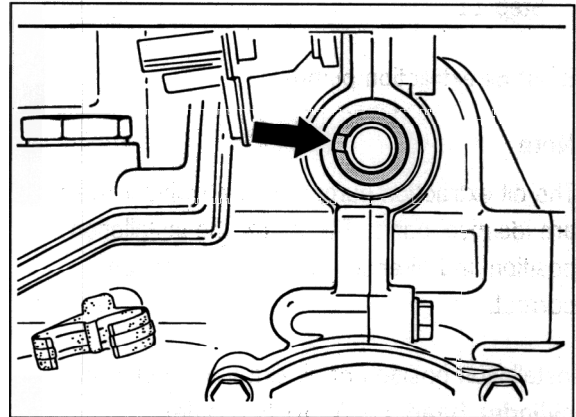

View from the belt pulley side

624_97

4. Turn engine 90° counterclockwise on the assembly support. **Cylinder bank 4 - 6** faces upward.
5. If the allocation is correct, the narrow segment must face the cylinder head cover on the opposite side of the cylinder head.

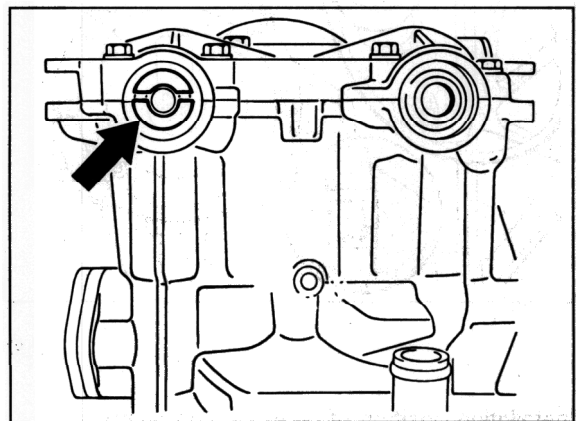

474_97

6. Fasten blocking device (special tool 9612) on the cylinder head (4 - 6).