







-  [Home](#)
-  [Chat o](#)
-  [Blogs](#)
-  [Members](#)
-  [Calendar](#)
-  [Donate](#)

## Author



Loren

[View Member's Tutorials](#)

## Tutorial info

**Added on:** Nov 15 2005 05:09 PM  
**Views:** 4574

## Collaboration

[Scouser](#), [miguelangelo97s](#) and [BealeAss](#) like this [Like](#)

**Description:** How to change your polyrib belt

**Note:** Part numbers sometimes change without notice. Always double check with your supplier that you have the latest part numbers.

### Parts you will need:

- 1 each 996 102 151 64 (or 996 102 151 66) Polyrib Belt (with air conditioning)
- or
- 1 each 996 102 151 65 Polyrib Belt (without air conditioning)

### Tools you will need:

- 13 mm socket or wrench (for air cleaner)
- Regular screwdriver (for air cleaner)
- 24 mm socket or wrench (for belt pulley)

Remove air cleaner housing.

Mark belt travel direction with a coloured pen (if you intend to reuse it).

**Note:** Never remove Polyrib belt when warm. The belt will deform and could be damaged.

Turn the tensioning roller 7 on the socket wrench (wrench size 24 mm) clockwise and simultaneously remove the belt from the drive pulleys.

Visually inspect the condition of the belt and replace it if necessary. Check belt pulley for damage.

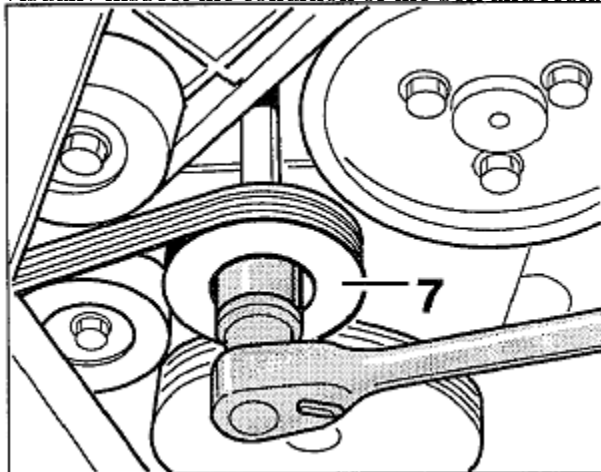

Install Polyrib belt in the order shown.

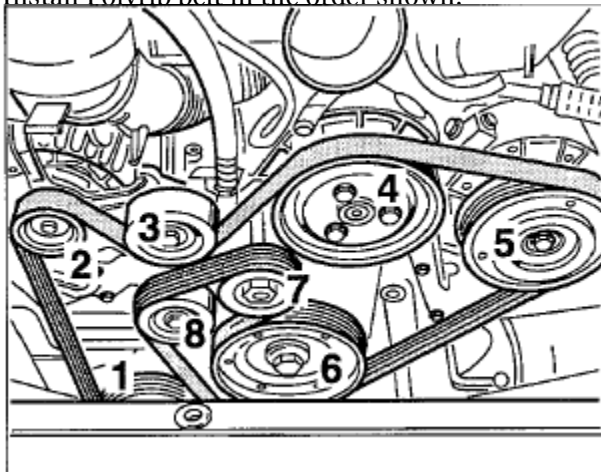

Twist the tensioning roller 7 clockwise and simultaneously place the belt on the idler pulley 8. Subsequently relieve the tensioning roller slowly. Visually check whether the belt is correctly positioned on all pulleys.

### Reinstall the air cleaner housing

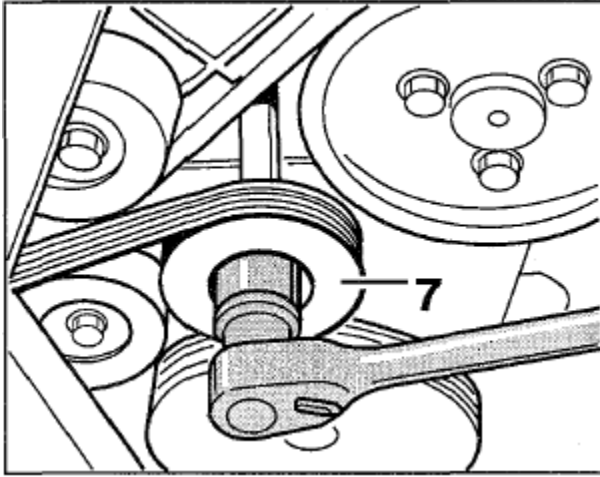

 [Report](#)

Be the first of your friends to like this.

Powered by Tutorials 1.2.2 © 2011, by [Michael McCune](#)

[Privacy Policy](#) [Copyrights/Credits](#)

[Donate to RennTech.org](#)



Porsche®, Carrera, Targa, Boxster, Cayenne, Cayman and the Porsche Crest are copyrighted and trademarks of Porsche AG.

RennTech.org is not in any way associated with Porsche AG or PCNA.

© 2003 - 2011 RennTech.org. All rights reserved.