

Modified Rear Hardtop Locking Mechanism

Vehicle Type: **911 Carrera (996) Cabriolet/ 911 Carrera 4 (996) Cabriolet**

Model Year: **As of 1999 (X) – 2005 (5)**

Concerns: **Noise complaints when driving with hardtop mounted.**
 - Install modified rear hardtop locking elements.

Information: On 911 (996) Cabriolet vehicles manufactured before the date of introduction listed below, noises can occur in the area of the C-pillar when driving with the hardtop mounted. As of the date of introduction, a modified hardtop locking mechanism has been installed in 911 (996) Cabriolet vehicles.

Distinguishing Features (modified/previous)

The catch (Figure 1, Item A) and insert of mounting console (Item B) are now threaded (arrow 1) on the modified locking mechanism.

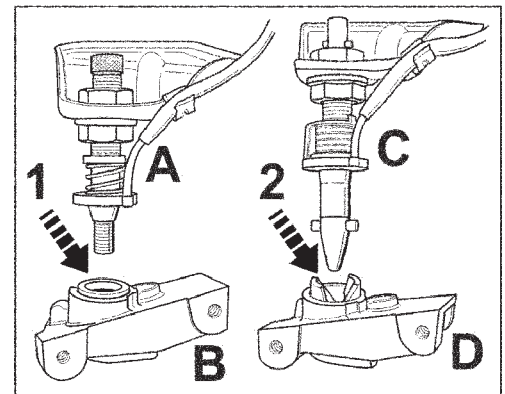

Figure 1

Up until the introduction date, the hardtop was locked using a bayonet catch (Figure 1, Item C) in the insert of the mounting console (Item D and arrow 2).

i Note!

The modified locking mechanism can be installed **retroactively** in the event of a repair or complaint. The locking mechanism must be replaced on the left and right side together (see Work Procedure).

It is not permitted to use the previous and the modified locking mechanism (**mixed configuration**) together. Due to the modified operation of the hardtop locking element, a supplement to the Owner's Manual must be given to the customer after the vehicle is converted.

Introduction: August 31, 2004, as of the following VIN:

99 25S 65 0211 911 Carrera (996)

Parts Information:	Part Number 000.043.300.46	Description New/modification kit for hardtop locking element
--------------------	--------------------------------------	--

The modification kit contains the following parts:

996.563.413.01	Tool for hardtop locking element (with black handle)
996.563.403.04	Left catch (screw catch)
996.563.404.04	Right catch (screw catch)
900.378.030.09	M6 x 20 screw for catch (6 ea. contained in set)
996.561.653.04	Left mounting (for screw catch)
996.561.654.04	Right mounting (for screw catch)
900.378.173.09	M6 x 20 screw to fasten the mounting (8 ea.)
WKD 996.719.05	Supplement to Owner's Manual

Work Procedure: 1. Remove hardtop, see POSES, Workshop Manual 911 Cabriolet, Group 6, 61 02 19 – Removing and installing hardtop.

2. Replace hardtop locking element, see POSES, Workshop Manual 911 Cabriolet, Group 6, 61 11 19 – Removing and installing hardtop locking element.

3. Replace mounting console on left and right.

3.1 Remove cover over the roll-over bar, see POSES, Workshop Manual 911 Cabriolet, Group 6, 69 72 19 – Removing and installing roll-over bar.

3.2 Remove left and right mounting console. The mounting consoles (Figure 2, arrow 1R/1L) are fastened with four M6 x 20 hexagon-head bolts each (Item 2). Disconnect the electrical plug connection on the left mounting, see POSES, Workshop Manual 911 Cabriolet, Group 6, 61 42 19 – Removing and installing rear side section flap.

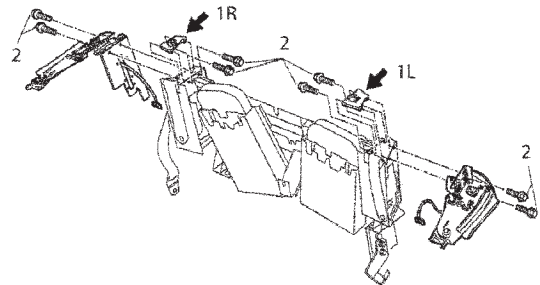

Figure 2

3.3 Install modified mounting console on the left (996.561.653.04) and right (996.561.654.04). Insert mounting console on the left/right on the vehicle and screw down with four M6 x 20 hexagon-head bolts each (Figure 2, Item 2). Tightening torque: 10 Nm (7.5 ftlb.). Connect the electrical plug connection on the left mounting, see POSES, Workshop Manual 911 Carrera Cabriolet, Group 6, 61 42 19 – Removing and installing rear side section flap.

4. Install cover over the roll-over bar, see POSES, Workshop Manual 911 Carrera Cabriolet, Group 6, 69 72 19 – Removing and installing roll-over bar.

5. Adjust hardtop, see POSES, Workshop Manual 911 Carrera Cabriolet, Group 6, 61 02 15 – Adjusting the hardtop.

Work Procedure:
(cont'd)

- 6. Lock hardtop.
- 7. Due to the conversion of the locking mechanism, the operation of the rear hardtop locking element has changed. Therefore, invalidate the corresponding pages in the Owner's Manual of the vehicle which was converted to the new hardtop locking element by making a diagonal cross through them.



Note!

Please inform the customer about the modified operation of the hardtop locking element when handing over the vehicle and give the customer the supplement for the vehicle Owner's Manual contained in the modification kit in the respective country's language.

References:

- POSES, Workshop Manual 911 Carrera Cabriolet (996):
- > Group 6: 61 02 19 – Removing and installing hardtop.
 - 61 02 15 – Adjusting the hardtop.
 - 61 11 19 – Removing and installing rear hardtop locking element.
 - 61 42 19 – Removing and installing rear side section flap.
 - 69 72 19 – Removing and installing roll-over bar.

Important Notice: Porsche Cars N.A Technical Bulletins are intended for use by professional technicians, not a "Do-it-yourselfer." They are written to inform these technicians of conditions that may occur on some vehicles, or to provide information that could assist in the proper service of a vehicle. Special tools may be required to perform certain operations identified in these bulletins. Use of tools and procedures other than those recommended in these bulletins may be detrimental to the safe operation of your vehicle. Properly trained technicians have the equipment, tools, safety instructions and know-how to do a job properly and safely. If a condition is described, do not assume that the bulletin applies to your vehicle, or that your vehicle will have that condition. See your Porsche Dealer for information on whether your vehicle may benefit from the information. Part numbers listed in these bulletins are for reference only. Always check with your authorized Porsche dealer to verify correct part numbers.

©2005 Porsche Cars North America, Inc.

Dealership	Service Manager	_____	Shop Foreman	_____	Service Technician	_____	_____	_____	_____
Distribution	Asst. Manager	_____	Warranty Admin.	_____	Service Technician	_____	_____	_____	_____
Routing									

Dr. Ing. h.c. F. Porsche AG is the owner of numerous trademarks, both registered and unregistered, including without limitation the Porsche Crest®, Porsche®, Boxster®, Carrera®, Cayenne®, Tiptronic®, VarioCam®, PCM®, 911®, 4S®, and the model numbers and distinctive shapes of Porsche's automobiles such as, the federally registered 911 automobile. The third party trademarks contained herein are the properties of their respective owners. Porsche Cars North America, Inc., believes the specifications to be correct at the time of printing. However, specifications, standard equipment and options are subject to change without notice.

Printed in the USA