

Porsche Classic Communication Management Plus (PCCM Plus)

Vehicle type: **911 (996) and Boxster (986)**

Model Year: **As of 1997**

Restriction: **1997 – 2005**

Important: For converting DIN1 radio (step 2) to PCCM Plus (DIN2), the parts listed in the **conversion parts list DIN1 to DIN2** must also be ordered.

Additional installation videos are available for installation, link:

[https://ppn.porsche.com/portal/community/dr\\_ing.\\_h.c.f.\\_porsche\\_ag/products\\_and\\_services/porscheclassic/blog/2020/06/19/update-technical-information-amp-videos-pccm-plus](https://ppn.porsche.com/portal/community/dr_ing._h.c.f._porsche_ag/products_and_services/porscheclassic/blog/2020/06/19/update-technical-information-amp-videos-pccm-plus)

Notes: Compared with Porsche Communication Management (PCM) generation 1 and 2.0, Porsche Classic Communication Management Plus (PCCM Plus) includes the following:

- Apple CarPlay®
- GOOGLE® Android Auto
- DAB+ Dual Tuner
- Digital touchscreen display (7-inch)
- External media box for USB/AUX/USB for Apple CarPlay/GOOGLE® Android Auto
- 2 x microSDHC card slots
- Bluetooth® hands-free system
- SiriusXM-Ready® (USA only)



Figure 1

Part No.: **996.642.590.00** ⇒ NAVIGATION SYSTEM, RoW (PCCM Plus)  
**996.642.591.00** ⇒ NAVIGATION SYSTEM, USA (PCCM Plus)

Conversion parts list DIN1 to DIN2: Only for vehicles with DIN1 radio  
 Important: Before beginning the conversion from DIN1 to PCCM Plus (DIN2), the parts listed in the conversion parts list DIN1 to DIN2 must also be ordered.  
 This conversion is explained in step 2.

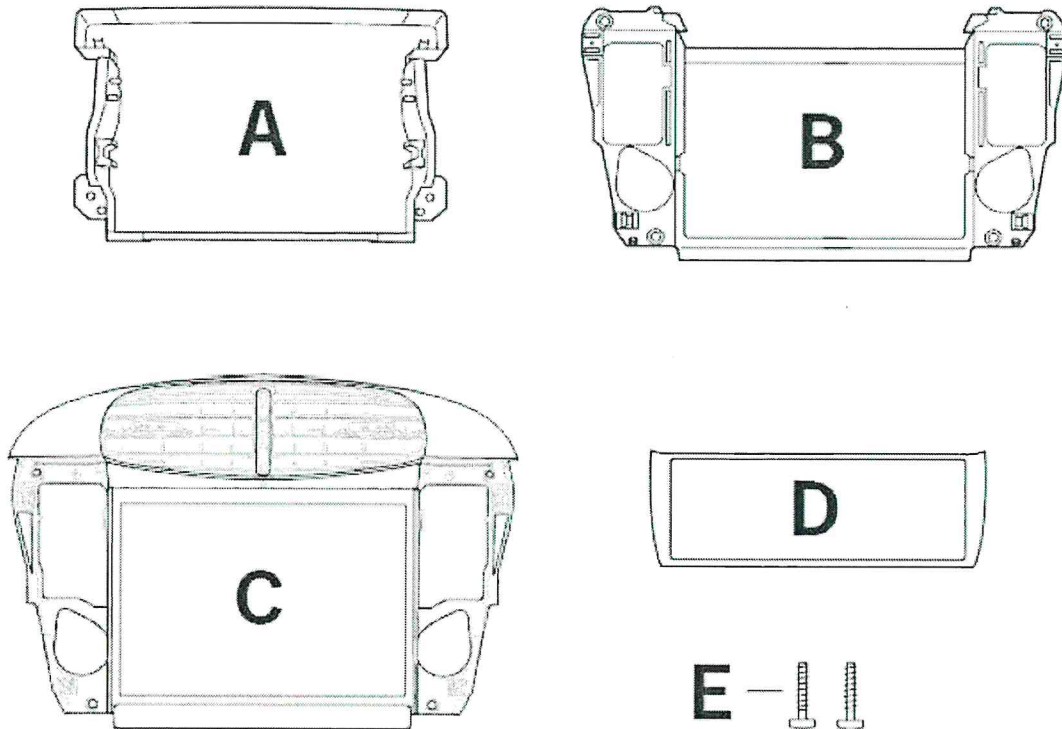

*Overview of conversion DIN1 to DIN2*

**911 Turbo (996), 911 GT3 from model year 2003, 911 (996) 2002–2005, Boxster (986) 2003–2004**

996.552.653.04	1 x	Retaining bar ⇒ <i>Overview of conversion DIN1 to DIN2</i>
996.552.231.12.01C*	1 x	Front support frame, black ⇒ <i>Overview of conversion DIN1 to DIN2</i>
996.552.339.00.01C*	1 x	Frame for air-conditioning control panel, black ⇒ <i>Overview of conversion DIN1 to DIN2-D-</i>
999.919.182.09	2 x	Oval-head screw ⇒ <i>Overview of conversion DIN1 to DIN2-E-</i>
<b>911 (996) 1998–2001</b>		
996.552.131.05.A03*	1 x	Front support frame, black ⇒ <i>Overview of conversion DIN1 to DIN2-C-</i>
996.552.339.00.01C*	1 x	Frame for air-conditioning control panel, black ⇒ <i>Overview of conversion DIN1 to DIN2-D-</i>

999.919.182.09	2 x	Oval-head screw ⇒ <i>Overview of conversion DIN1 to DIN2-E-Boxster (986) 1997-2002</i>
986.552.131.09.A03*	1 x	Front support frame, black ⇒ <i>Overview of conversion DIN1 to DIN2-C-</i>
996.552.339.00.01C*	1 x	Frame for air-conditioning control panel, black ⇒ <i>Overview of conversion DIN1 to DIN2-D-</i>
999.919.182.09	2 x	Oval-head screw ⇒ <i>Overview of conversion DIN1 to DIN2-E-</i>

\* Colours and materials that were originally used are subject to availability. Communicate colour deviations to the customer during the sales process.

Note: If the media box is not installed in the glove box, storage compartment 996.552.253.01C must be ordered.

PCCM parts list:

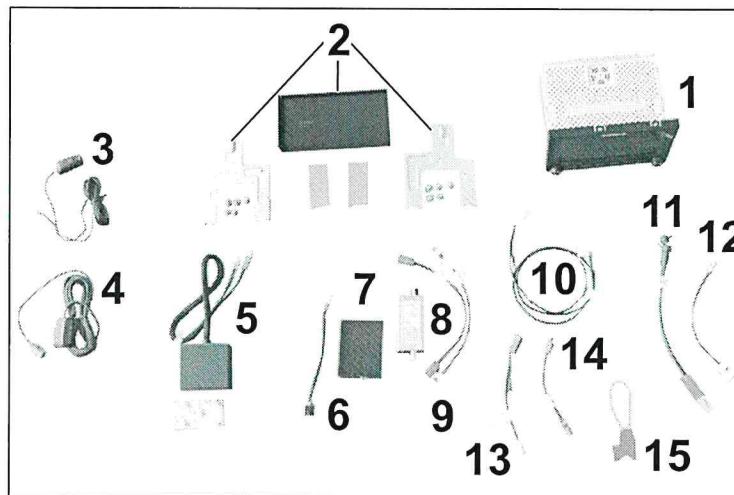

Figure 2

996.642.590.00	1 x	Porsche Classic Communication Management Plus, RoW ⇒ <i>Figure 2-1-</i>
996.642.591.00	1 x	Porsche Classic Communication Management Plus, USA ⇒ <i>Figure 2-1-</i>
996.642.595.00	1 x	Mounting parts ⇒ <i>Figure 2-2-</i>
911.645.507.00	1 x	Microphone ⇒ <i>Figure 2-3-</i>
911.645.505.00	1 x	GPS antenna ⇒ <i>Figure 2-4-</i>
911.645.513.00	1 x	Multimedia interface ⇒ <i>Figure 2-5-</i>
996.642.580.00	1 x	MOST control unit with connecting line ⇒ <i>Figure 2-6-</i> and ⇒ <i>Figure 2-7-</i>
911.645.574.00	1 x	DAB receiver, <b>RoW ONLY</b> ⇒ <i>Figure 2-8-</i> and ⇒ <i>Figure 2-9-</i>
996.642.573.00	1 x	Adapter antenna cable for antenna without diversity, <b>RoW ONLY</b> ⇒ <i>Figure 2-10-</i>
911.642.313.00	1 x	Sirius XM® connecting line, <b>USA ONLY</b> ⇒ <i>Figure 2-11-</i>
911.645.574.55	1 x	Antenna adapter plug <b>USA ONLY</b> ⇒ <i>Figure 2-12-</i>
996.642.574.00	1 x	Diversity antenna splitter, <b>RoW ONLY</b> ⇒ <i>Figure 2-13-</i>

996.642.575.00	1 x	Adapter + antenna wire harness for diversity control unit, <b>RoW ONLY</b> ⇒ <i>Figure 2-14-</i>
996.642.585.00	1 x	MOST bridge ⇒ <i>Figure 2-15-</i>

**Important: The relevant map material is provided via a separate SD card:**

996.642.501.00	1 x	SD memory card for navigation system with navigation data for Europe
996.642.502.00	1 x	SD memory card for navigation system with navigation data for USA, Canada

For vehicles on which PCM generation 1 (M662) is installed, the following parts are also required:

996.612.009.01	1 x	GPS antenna connecting line M662
996.642.587.00	1 x	Ground line for amplifier M662 + M680

On 986 vehicles with a new 987.647.105.00 antenna amplifier, the antenna line 986.642.573.00 must also be ordered.

Fitting:

**Important:** Before installing PCCM Plus, please check that the sound system is functioning correctly using the system tester. If there is a fault, this must be corrected beforehand.

1 Preliminary work

- 1.1 Remove battery cover and disconnect and cover the battery.
- 1.2 Remove radio, heating/air-conditioning control panel, trim for switches, centre air vents and front retaining bracket for radio.
- 1.3 Remove left trim panel for centre console, centre console trim, CD compartment and storage compartment.
- 1.4 Pull standard radio out of its slide-in module and disconnect electric plug connection.

2 Conversion of air-conditioning control panel

- 2.1 Route wire harness for heating/air-conditioning control panel ⇒ 2.1 from the installation opening ⇒ 2.1 in the dashboard to the installation slot ⇒ 2.1-C in the centre console and secure it.
- 2.2 Pull insert sleeves off old trim for heating/air-conditioning control panel and insert them into the heating/air-conditioning control panel ⇒ 2.2.
- 2.3 Insert connector into heating/air-conditioning control panel.

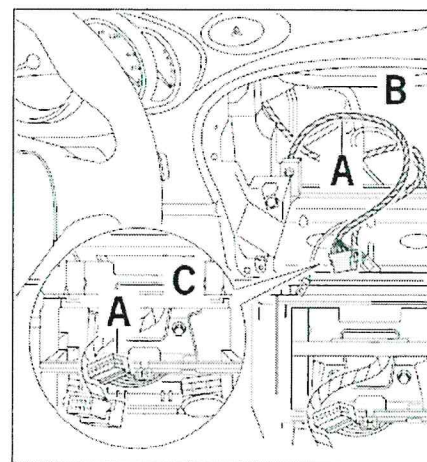

2.1

- 2.4 Insert heating/air-conditioning control panel ⇒ 2.2 into the lower installation slot of the centre console and secure with screws ⇒ 2.2-C - .  
NOTE: Use new screws (Torx 4 x 20, see parts list).

- 2.5 Insert rear retaining bar ⇒ 2.2 for PCM2 and secure with screws

3 Fitting (M440) RoW

- 3.1 Remove left A-pillar, **only for ROW vehicles with antenna diversity (M440)**

- 3.2 Unplug connector ⇒ *Figure 3-2-* and connector ⇒ *Figure 3-3-* from antenna ⇒ *Figure 3-1-* under the left A-pillar trim panel.

- 3.3 Connect antenna connector ⇒ *Figure 4-2-* and vehicle cable connector ⇒ *Figure 4-3-* with adapter cable 996.642.574.00 ⇒ *Figure 2-13-*. Screw ground line ⇒ *Figure 4-1-* to ground point ⇒ *Figure 4-4-*.

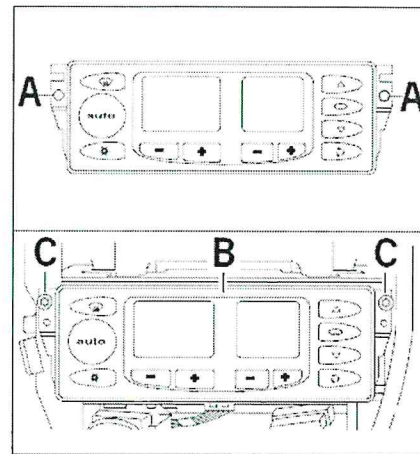

2.2

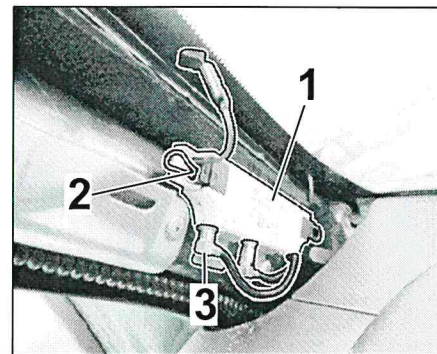

Figure 3

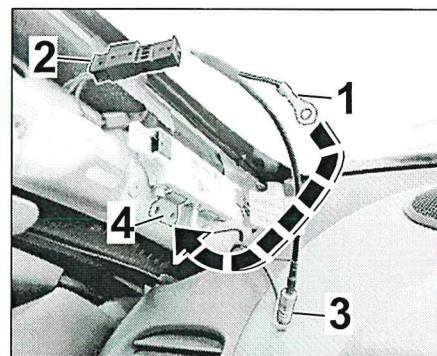

Figure 4

- 3.4 Remove antenna diversity control unit in the passenger footwell. Detach antenna cable from antenna diversity control unit ⇒ *Figure 5-1-*.

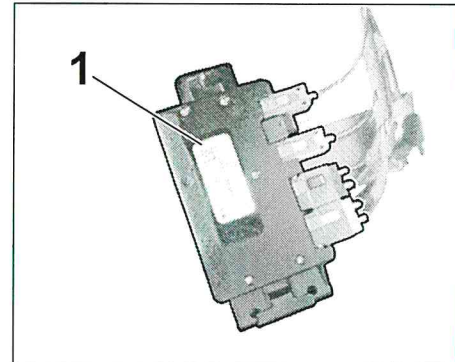

Figure 5

- 3.5 White single-pin connector ⇒ *Figure 6-2-* and black double-pin connector ⇒ *Figure 6-3-*.  
Bridge using antenna bridge ⇒ *Figure 2-14-*.

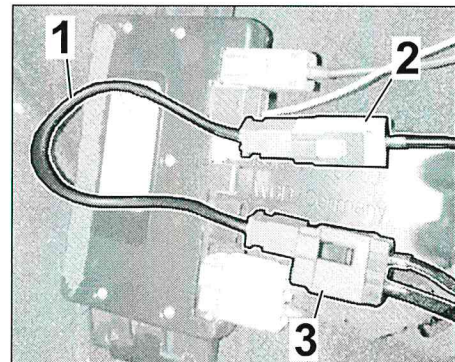

Figure 6

- 4 Remove A-pillar at the right.

- 4.1 On all ROW vehicles without M440, route adapter cable from antenna ⇒ *Figure 7-2-* to PCCM Plus radio slot. Disconnect windscreen antenna from the antenna amplifier ⇒ *Figure 7-2-*. Connect ⇒ *Figure 7-5-* windscreen antenna to adapter cable ⇒ *Figure 2-10-*. Loosen screw ⇒ *Figure 7-3-* and fit ground line ⇒ *Figure 7-4-*. Tighten the screw again.

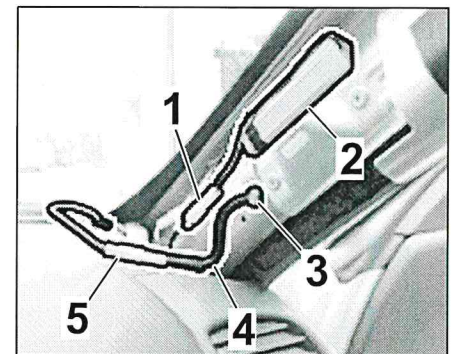

Figure 7

- 4.1.1 On 986 vehicles with antenna amplifier 987.647.105.00, adapter cable 986.642.573.00 (not included in scope of delivery) must be used.

- 5 Fitting add-on parts for ROW and USA  
Fit microphone ⇒ *Figure 5-2-* for hands-free equipment on the steering column casing. Route the microphone cable to the PCCM Plus. The microphone installed in the vehicle cannot be used (**M618, 666**).

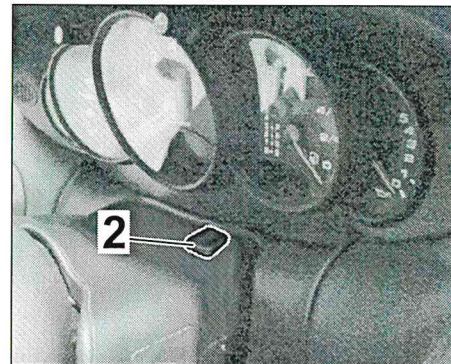

Figure 8

- 5.1 On vehicles that do not have a GPS antenna installed as standard, fit GPS antenna ⇒ *Figure 2-4-* in the dashboard area and route the cable to the PCCM Plus.  
**For M662 up to 2002 (PCM1)**, please also use the following: 996.612.009.01 (not included in scope of delivery). Connect the GPS antenna (on the navigation computer) installed at the factory to the PCCM Plus using the adapter cable. Alternatively, the supplied GPS antenna can be used.



Figure 9

- 5.1.1 Fit the supplied media interface ⇒ *Figure 2-5-* in the centre console storage compartment ⇒ *Figure 9-1-*. Alternatively, the media box can also be installed in the glove box ⇒ *Figure 10-1-*

Note: The cable for the media box must be no longer than 50 cm in order to ensure data quality. During installation, the media box must only be secured in the installation position after fitting the PCCM Plus.

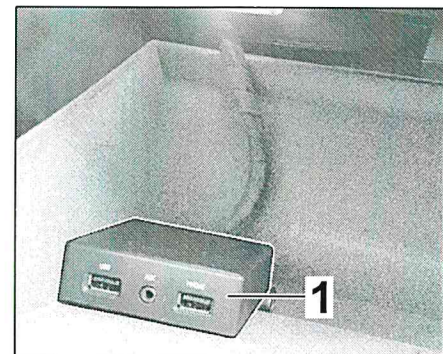

Figure 10

- 6 Fitting device

- 6.1 On vehicles with M662 up to model year 2002, the alarm contact ⇒ *Figure 11-1-* on the retaining frame must be insulated.



Figure 11

- 6.2 Secure the side panel at the left and right ⇒ *Figure 12-3-* to the transverse strut ⇒ *Figure 2-2-* using two screws on each side ⇒ *Figure 12-1-*. Fit ⇒ *Figure 2-2-*.

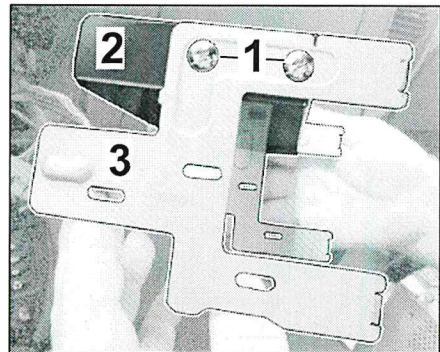

Figure 12

- 6.3 Insert device ⇒ *Figure 13-2-* into Z retaining bracket ⇒ *Figure 13-1-* and fit the side panels with transverse strut on the device from the rear. Check that the device is fitted securely. Screw the device to the Z retaining bracket with four screws.

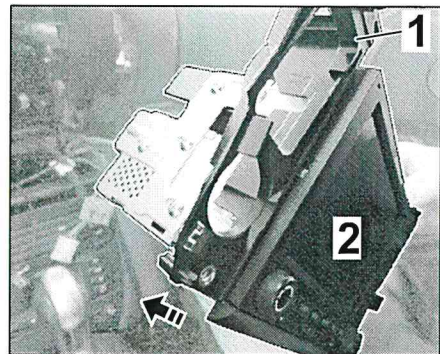

Figure 13



6.4 Installation of MOST control unit ⇒ *Figure 2-6, 7-ROW and USA:* . Affix MOST control unit ⇒ *Figure 14-2-* on the transverse strut of the Z retaining frame ⇒ *Figure 14-3-* using the supplied double-sided adhesive strip and connect the plug connection to the device.

6.5 Affix DAB box ⇒ *Figure 2-8-RDW only:* ⇒ *Figure 14-1-* on the transverse strut of the Z retaining frame ⇒ *Figure 14-3-* using the supplied double-sided adhesive strip and connect the plug connection to the device. Routing lines for DAB receiver ⇒ *Figure 2-9-* under the transverse strut

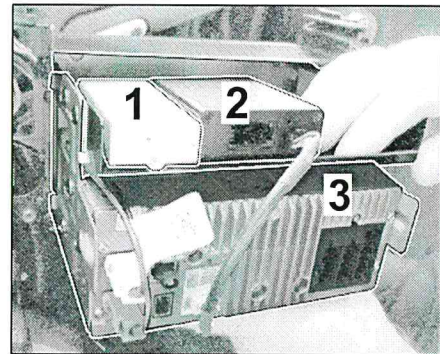

Figure 14

**For M665 with M622 from 2003:⇒**  
*Figure 2-12-* must also be used.

6.5.1 Fit the supplied MOST bridge ⇒ *Figure 15-1-* 996.642.585.00 on the CD changer ⇒ *Figure 15-2-*.

6.5.2 Fitting ground line: On vehicles (1997–2001) with M662 (PCM generation 1) and M680 (Digital sound package), an additional ground line 996.642.587.00 must be routed to the amplifier. **Ground line not included in scope of delivery.**

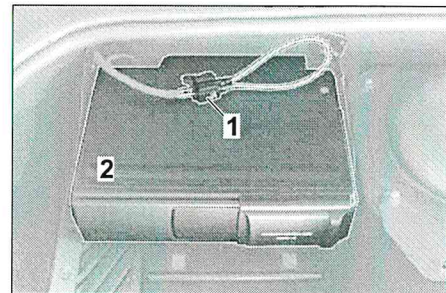

Figure 15

Disconnect black 18-pin connector housing from the amplifier ⇒ *Figure 15.2* .

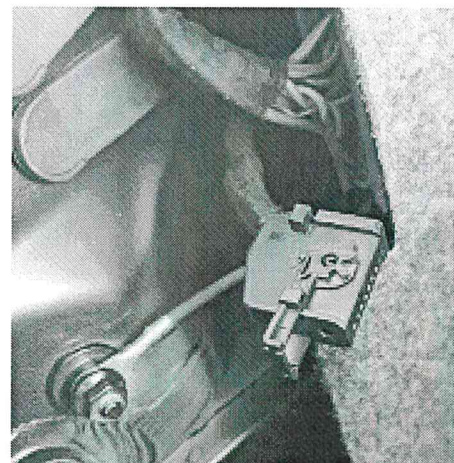
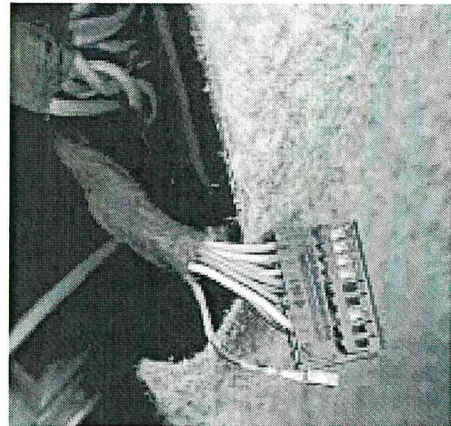

Figure 15.2

Remove fuse on connector housing and disconnect and insulate (DSP data) line, contact no. 17 black/red/yellow. ⇒ *Figure 15.3*



*Figure 15.3*

Connect additional ground line 996.642.587.00 at contact no. 17. Re-fit connector housing ⇒ *Figure 15.4*

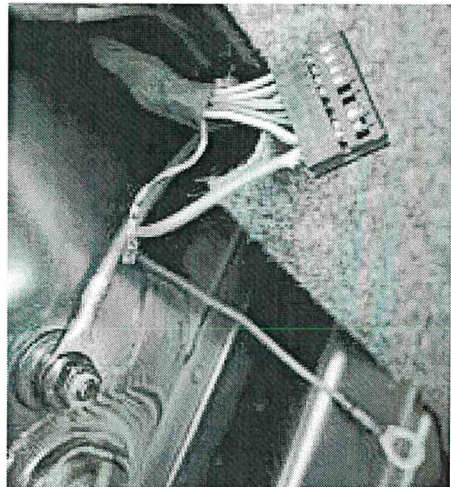

*Figure 15.4*

Secure ground line at the ground points. Re-fit black connector on the amplifier. ⇒ *Figure 15.5*

- 6.6 Slide device with retaining frame into the installation slot and complete the vehicle.
- 6.7 Read out the fault memory and clear it if necessary. Faults that are present following installation and are not deleted can be ignored.

**Important note:** The device cannot be diagnosed for technical reasons. As a result, the following faults will be entered in the fault memory.

- 9114 PCM control unit
- 9151 Unknown error

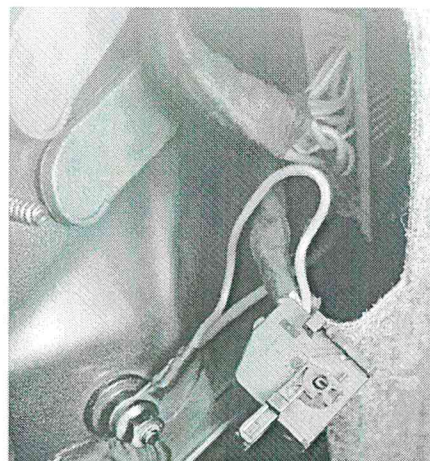

*Figure 15.5*

The faults do **not** affect other functions in the vehicle and can be **ignored**.

- 7 **Note:** On vehicles (1997–2002) with M662 (PCM1), the amplifier output must be activated in the Porsche Classic Communication Management Plus (PCCM Plus). Unless this is activated, no sound will be heard from the loudspeakers when the device is switched on.

No 12-volt output voltage is emitted on the mini ISO connector (yellow) pin 6. To activate this, please proceed as follows:

- 7.1 Select the **Settings** button in the HOME screen.



*Figure 16*

- 7.2 Select the **Volume** menu item and touch and hold it for approx. 10 seconds.

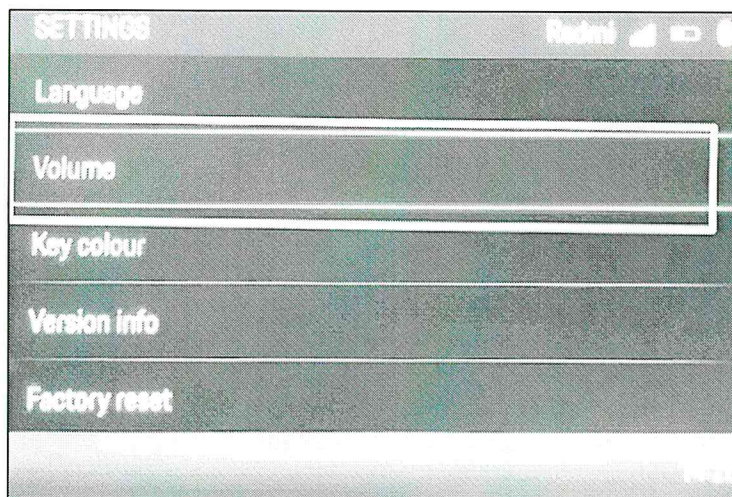

Figure 17

- 7.3 Press the **CAN** Switch button once to change from CAN to **AMP**.

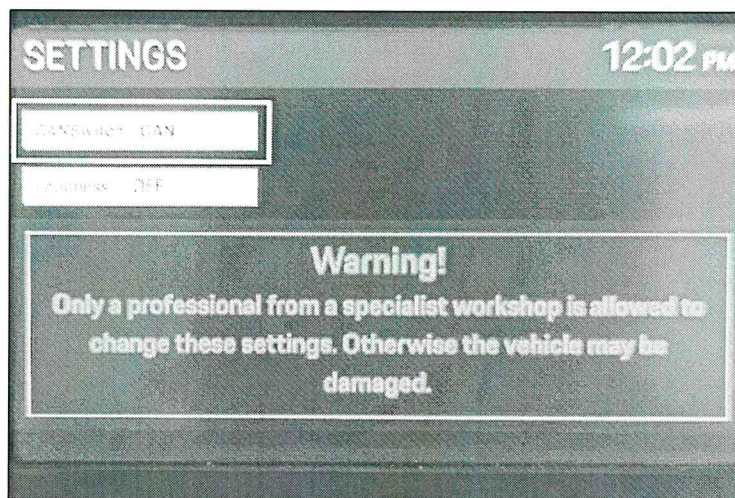

Figure 18

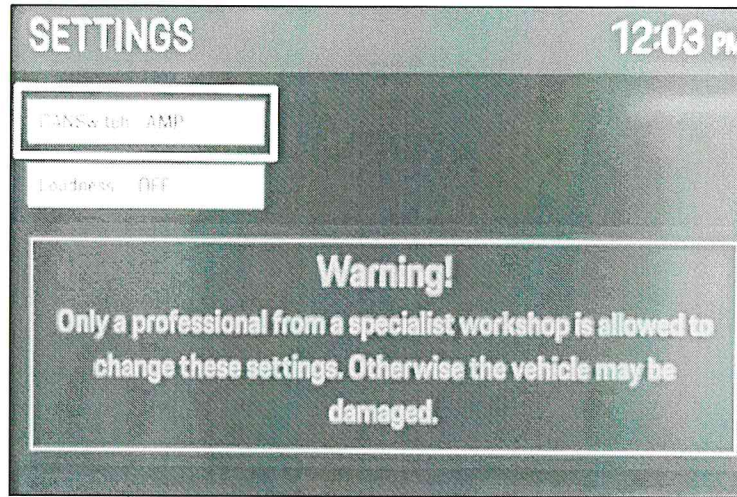

Figure 19

7.4 Restart the device.

91102340: Installing Porsche Classic Communication Management Plus

Labor time: 320 TU