

PORSCHE®**Technical Information****911 (993)****2/01 9752****9**

Binder - Service Technical Bulletins

W301-Replacement of Engine Wiring HarnessVehicle Type: **911 Carrera (993) / 911 Carrera 4 (993)**Model Year: **MY 1995 (S) and MY 1996 (T)**Concern: **Engine wiring harness**

Information: Porsche is requesting that the engine wiring harness be checked and/or replaced on a certain range of model year 1995 and 1996 911 Carrera (993) and 911 Carrera 4 (993) vehicles.

Based on field information and internal testing, Porsche AG has concluded that the insulation of the wires of the wiring harness may deteriorate. The deterioration of multiple wires may result in shorts which affect the proper function of the engine. Rough engine running, stalling, inability to start the engine due to a dead battery, starter malfunction, and illumination of the Malfunction Indicator Light ("Check Engine" warning lamp) are symptoms for this problem.

The engine wiring harness part number must be checked on all affected vehicles. Depending on what you find when you inspect the vehicle, the wiring harness may then also need to be replaced.

Affected Vehicles: A total of 10,300 U.S. and 455 Canadian vehicles fall within the scope of this Service Action.

Very Important! Not every vehicle in the below listed range may be affected. Use the ranges below as a general guideline. Alternatively, the VIN can be checked in the Porsche E-DCS/WWS for confirmation of an open service action (or recall campaign). Also, the VIN can be checked via the VRU (Voice Response System) for any open listing.

The affected Vehicle Identification Numbers are **contained** in the following VIN-Ranges:

Model Year 1995 Vehicles:

WPOAA299XSS320061 to WPOAA2998SS324139 Coupe (U.S. Vehicles)
 WPOCA2997SS340065 to WPOCA2998SS343718 Cabriolet (U.S. Vehicles)
 WPOAA2993SS320158 to WPOAA2990SS324104 Coupe (Canadian Vehicles)
 WPOCA2990SS340389 to WPOCA2990SS343535 Cabriolet (Canadian Vehicles)

Model Year 1996 Vehicles:

WPOAA2996TS320074 to WPOAA2990TS321902 Coupe (U.S. Vehicles)
 WPOCA2998TS340061 to WPOCA2990TS341155 Cabriolet (U.S. Vehicles)
 WPODA2990TS385063 to WPODA2990TS385273 Targa (U.S. Vehicles)
 WPOAA299XTS320143 to WPOAA2991TS321620 Coupe (Canadian Vehicles)
 WPOCA2999TS340120 to WPOCA2993TS341098 Cabriolet (Canadian Vehicles)
 WPODA299XTS385068 to WPODA2994TS385244 Targa (Canadian Vehicles)

Customer Notification

Porsche Cars North America, Inc. will notify all known Vehicle Owners directly by First Class Mail during the week of October 21, 2002, as per attached Notification Card located in Attachment "A"

PORSCHE®

9 911 (993)
 9752 2/01

Technical Information**Work Procedure:** See Attachment "B".**Administrative Procedure:** See Attachment "C"**Customer Reimbursement Procedure:** See Attachment "D"

Parts Required:	Part Number	Quantity	Description
	000 043 204 61	1	Part set for naturally aspirated engine Contains: 1- Engine wiring harness (993 607 016 15) 1- Adapter for heating connector (connected to wiring harness) 1- Dummy plug for secondary air pump connector (connected to wiring harness) 1- Dummy plug for switch over valve connector for secondary air pump (connected to wiring harness) 1- Dummy plug for fan belt monitoring (connected to wiring harness) 1- Adaptor for heating connector (connected to wiring harness)

PORSCHE®

Technical Information

911 (993)

2/01 9752

9

Attachment "A" Customer Notification Card

SERVICE ACTION NOTICE

Re: W301 Customer Service Campaign Action

Dear Porsche Owner:

Our records indicate that you are the Owner of a Porsche 911 Carrera (993), model year 1995 or 1996 vehicle that may be affected by a Workshop Service Action concerning the engine wiring harness.

Porsche AG, initiated this voluntary customer service campaign action based on field information and internal testing, and concluded that the insulation of the wires of the harness may deteriorate. Deterioration of multiple wires may result in shorts which affect the proper function of the engine. Rough engine running, stalling, inability to start the engine due to dead battery, starter malfunction, and illumination of the Malfunction Indicator Light ("Check Engine" Warning Lamp) are symptoms for this problem.

In order to avoid such faults arising, the engine wiring harness of your Porsche must be checked. Depending on the results of these checks, the wiring harness may then also need to be replaced.

You should arrange for an appointment with your Porsche dealer as soon as possible to have the required work performed. The necessary parts to perform this service campaign action will be available at your Porsche dealer. The estimated time to perform the repair is approximately six to eight hours and will be completed at no charge to you. Please allow yourself and your Porsche dealer additional time to complete the repairs.

If you have already paid for the engine wiring harness of your Porsche to be replaced or repaired due to this particular problem, you will still need to have your vehicle inspected. Please send all documents in the enclosed postage-paid envelope for our review. The costs that you previously incurred may be reimbursable to you.

If your Porsche dealer is unable to perform this repair within a reasonable period of time, you may call or write:

Porsche Cars North America, Inc.
 980 Hammond Drive, Suite 1000
 Atlanta, Georgia 30328
 Attention: Customer Commitment Telephone: 1-800-Porsche (767-7243)

We sincerely regret any inconvenience this Customer Campaign may cause, and hope you understand our interest in performing this work promptly so that you can be satisfied with your Porsche automobile. Please accept our apologies for this unplanned service visit.

Sincerely, Porsche Cars North America, Inc.



BUSINESS REPLY CARD

FIRST CLASS PERMIT NO. 26231 ATLANTA, GA

POSTAGE WILL BE PAID BY ADDRESSEE

Porsche Cars North America, Inc.
 Attn: Customer Commitment
 980 Hammond Drive, Suite 1000
 Atlanta, Georgia 30328-9735

NO POSTAGE
NECESSARY
IF MAILED
IN THE
UNITED STATES



PORSCHE®

9 911 (993)
9752 2/01

Technical Information

Attachment "A" Customer Notification Card
(cont'd)

PORSCHE®
Porsche Cars North America, Inc.
 980 Hammond Drive, Suite 1000
 Atlanta, Georgia 30328

SERVICE ACTION NOTICE

Vehicle Identification Number	Recall W301	Dealer #
-------------------------------	-----------------------	----------

If you no longer own this automobile or your address is different from that shown below, please complete this postage pre-paid card, detach and return.

My correct address is: or I sold this vehicle to:

Last Name	First Name	Initial
Number	Street	
City	State	Zip

Vehicle totaled/scrapped: }
 Vehicle reported stolen: }
 Vehicle has been exported: }

Vehicle Identification Number	Recall	Dealer #
-------------------------------	--------	----------

Please print and give complete information.

PORSCHE®

Technical Information

911 (993)**2/01 9752****9**

Attachment "B"

Work Procedure: Follow the steps below and refer to the enclosed excerpt from the Technical Manual at the end of this bulletin for the actual work procedure.

- 1.** Check the part number of the engine wiring harness. Use the criteria in section 97-1, pages 1 and 2 to determine if the wiring harness needs to be replaced.
- 2.** If the part number on the harness matches up with a part number listed in the table located in section 97-1 page 2, the harness needs to be replaced. Replace the harness then go to step 4.
- 3.** If the part number on the harness does not match up with a part number listed in the table located in section 97-1 page 2, the harness does not have to be replaced. Continue with step 4.
- 4.** Enter the campaign in the Warranty and Maintenance book.

Literature:

911 Carrera (993) Technical Manual, Group 9:

>Repairs: 97 52 55 – Replacing the wiring harness for the naturally-aspirated engine (enclosed with this bulletin)

PORSCHE®

9 911 (993)
9752 2/01

Technical Information**Attachment "C"****Administrative Procedure, Service Action W301**

Engine Wiring Harness

Warranty claims should be submitted via e-dcs

Note: Always check for open recall status under the appropriate e-dcs menu options.**Affected VINs:** See Attachment "A"**Labor Operation:** Will be automatically inserted along with the necessary parts when the damage code is entered.**Warranty Code:** R**Scope 1:** Checking the part number of the engine wiring harness.**Damage Code:** W301 066 000 1 (for W301)**Repair Code:** 1**Time Units:** 30 TU**Scope 2:** Checking and replacing the engine wiring harness on MY 1995 (S) vehicles **without** intake tuning flap system (Vario Ram) and **without** air conditioning.**Damage Code:** W301 066 000 1 (for W301)**Repair Code:** 2**Time Units:** 420 TU

Parts:	Part Number	Description
	000 043 204 61	Wiring Harness Kit

Scope 3: Checking and replacing the engine wiring harness on MY 1995 (S) **without** intake tuning flap system (Vario Ram) and **with** air conditioning.**Damage Code:** W301 066 000 1 (for W301)**Repair Code:** 2**Time Units:** 450 TU

Parts:	Part Number	Description
	000 043 204 61	Wiring Harness Kit

PORSCHE®**Technical Information**911 (993)
2/01 9752**9****Attachment "C" (cont'd)**

Scope 4: Checking and replacing the engine wiring harness on MY 1996 (T) **with** intake tuning flap system (Vario Ram) and **without** air conditioning.

Damage Code: W301 066 000 1 (for W301)

Repair Code: 2

Time Units: 490 TU

Parts:	Part Number	Description
	000 043 204 61	Wiring Harness Kit

Scope 5: Checking and replacing the engine wiring harness on MY 1996 (T) **with** intake tuning flap system (Vario Ram) and **with** air conditioning.

Damage Code: W301 066 000 1 (for W301)

Repair Code: 2

Time Units: 530 TU

Parts:	Part Number	Description
	000 043 204 61	Wiring Harness Kit

In cases where the recall cannot be performed, submit this information on a claim via e-dcs with the appropriate disposition code by inserting the code in the last digit of the damage code, as shown below.

Disposition/Repair code

- 3 - Total Loss
- 4 - Vehicle Stolen
- 5 - Vehicle left North America
- 6 - Customer Moved/address unknown
- 7 - Vehicle sold, new owner information
- 9 - Customer refused to comply

Owner name and address change

If the owner name and address are shown incorrectly, submit a correction using the name/address postcard from the Warranty Maintenance Booklet (or Recall mailing), or report the change to the Warranty Department via e-dcs, including VIN.



9 911 (993)
9752 2/01

Technical Information

Attachment D: Reimbursement to customer for previously repaired vehicles.

Important! The harness check must be performed before we will reimburse the customer.

The customer was sent a form and a postage paid envelope with the Service Action notification. The customer must completely fill out the form, attach the appropriate receipts, and mail it to PCNA to be considered for reimbursement.

The customer must follow these steps to be considered for reimbursement:

1. Repair order in which the harness replacement is listed, and why it was replaced. We will only reimburse customers if the harness was defective as listed in this bulletin.
2. Receipt of payment showing the amount that was paid for the replacement.
3. Complete the reimbursement form. If the customer has misplaced the reimbursement form, copy the form on the back of this page and provide it to him/her.
4. Send in the documents to Porsche Cars North America, attention W301 Customer Reimbursement. We will review the documents and determine if a check will be issued.

Porsche Cars North America, Inc.
Attn: W301 Customer Reimbursement
980 Hammond Drive, Suite 1000
Atlanta, Ga. 30328

Important Notice: Porsche Cars N.A. Technical Bulletins are intended for use by professional technicians, not a "Do-it-yourselfer." They are written to inform these technicians of conditions that may occur on some vehicles, or to provide information that could assist in the proper service of a vehicle. Special tools may be required to perform certain operations identified in these bulletins. Use of tools and procedures other than those recommended in these bulletins may be detrimental to the safe operation of your vehicle. Properly trained technicians have the equipment, tools, safety instructions and know-how to do a job properly and safely. If a condition is described, do not assume that the bulletin applies to your vehicle, or that your vehicle will have that condition. See your Porsche Dealer for information on whether your vehicle may benefit from the information. Part numbers listed in these bulletins are for reference only. Always check with your authorized Porsche dealer to verify correct part numbers.

©2002 Porsche Cars North America, Inc.

Dealership	Service Manager _____	Shop Foreman _____	Service Technician _____	_____	_____
Distribution	Asst. Manager _____	Warranty Admtn. _____	Service Technician _____	_____	_____
Routing					

Porsche, the Porsche marque, 911, Carrera, Boxster, Cayenne, Tiptronic, VarioCars, VarioRams, Varrera, Tequipment, PCCB, PCNA EDCS, and PCM are registered trademarks. The distinctive shapes of the Porsche automobiles are trademarks of Dr. Ing. h.c.F. Porsche AG.

PORSCHE®

Technical Information

911 (993)
2/01 9752

9

PORSCHE®**Customer Reimbursement Application Form – Service Action W301****To Ensure Prompt turn around, please complete all required fields and include a copy of the paid invoice.**

Although repairs to the wiring harness were previously completed, it is extremely important to have the wiring harness inspected and, if necessary, replaced at your local Porsche Dealership. **If you have not completed this Service Action, Porsche Cars North America cannot issue a reimbursement for past repairs.** Please complete the section below and provide a copy of your current invoice. We will only issue a reimbursement if the wiring harness was defective as described in this Service Action. Porsche Cars North America will not reimburse for incidental expenses related to the repair or replacement of the wiring harness as described in this Service Action. Thank you.

Current Inspection/Repair Information:

Date of Repair: _____ Mileage/Kilometers: _____

Dealer Name: _____ Repair Order Number: _____

Owner Information: Vehicle Identification Number (VIN): _____Current Owner? Yes No If "No", was vehicle sold to a Dealer or private person? Yes No

If known, please provide address of new owner:

New Owner Name: _____

Address: _____

City: _____ State/Prov.: _____ Zip/Postal Code: _____

Your Name: _____

Address: _____

City: _____ State/Prov.: _____ Zip/Postal Code: _____

Home Phone #: _____ Work Phone #: _____

Previous Repair Information: (Important: Please attach copy of paid invoice.)

Date of Repair: _____ Mileage/Kilometers: _____

Dealer Name: _____ Repair Order Number: _____

Independent Repair Facility: Yes No (Please Check One)**Reimbursement Information:** (Check One) Total reimbursement requested: \$ _____ Labor Only Parts and Labor

Important Note: Only labor and parts needed to replace the wiring harness (or applicable repairs) will be considered for reimbursement and must be fair and reasonable. Please allow up to six weeks to process your request. **Incomplete forms will be returned**

Porsche Cars North America Review and Comments:

Check Number: _____ Claim Submission Date: _____

Date Check Issued: _____ Amount of Check: _____

Table of Contents

9 Electrical system

97 Wiring

97 52 55	Replacing the wiring harness for the naturally-aspirated engine	97-1	page 1
	Tools	97-1	page 1
	Check the wiring harness for the engine	97-1	page 1
	Wiring harness connections	97-1	page 3
	Remove the wiring harness for the engine	97-1	page 5
	Installing the wiring harness for the engine	97-1	page 14
	Tightening torques	97-1	page 25

Replacing the wiring harness for the naturally-aspirated engine

Tools

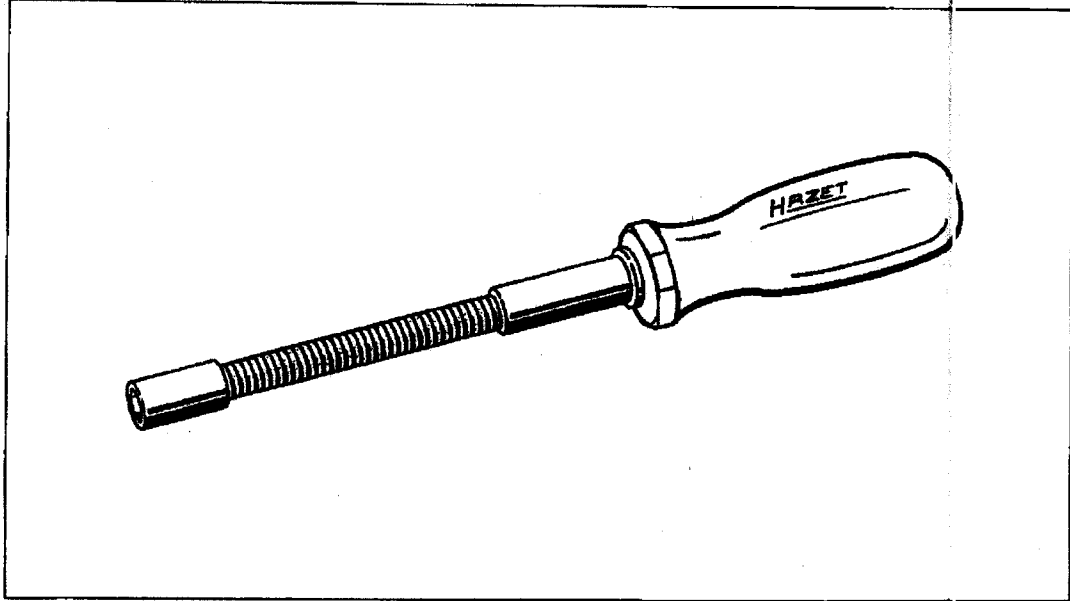

Item	Designation of the tool	Remarks
	Assembly tool for hose clamps	Refer to Workshop Equipment Manual, Chapter 2.4, No.: 73-1

Check the wiring harness for the engine

1. Remove the cover from the relay carrier in the engine compartment. Unscrew the three screws -arrows- for this purpose.

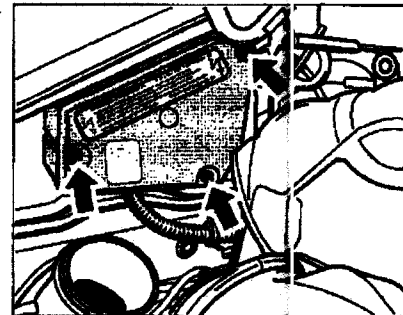

97

Wiring

911 Carrera (993)

2. Check the part number of the wiring harness. The part number is affixed to the wiring harness **-arrow-** in the relay carrier in the engine compartment. If one of the following part numbers has been printed on the wiring harness or if the part numbers can no longer be read, the wiring harness must be replaced.

Replace the wiring harness if any of the following part numbers are present

	Part number
1	993.607.016.00
2	993.607.016.01
3	993.607.016.04
4	993.607.016.05
5	993.607.016.06
6	993.607.016.07
7	993.607.016.08
8	993.607.016.80

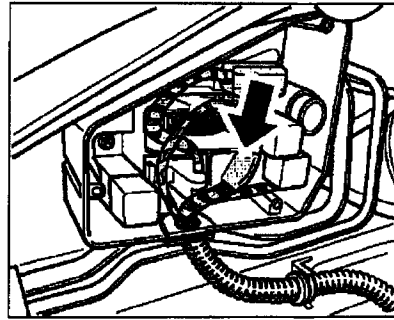

Wiring harness connections

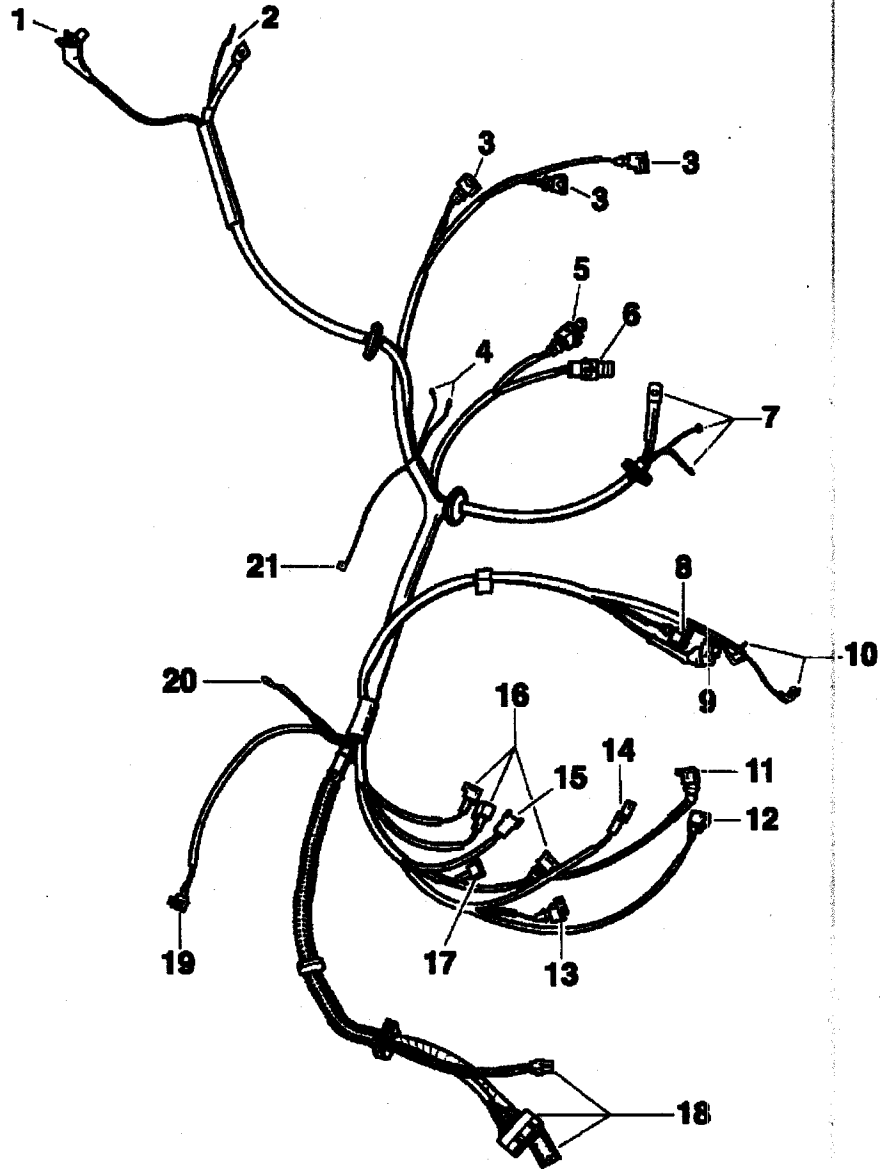

97 52 55 Replacing the wiring harness for the naturally-aspirated engine

Printed in Germany, 2002

993-Sauger

97-1 page 3

97

Wiring

911 Carrera (1993)

No.	Designation	Qty.	Removal	Installation
1	Reversing light switch connections	2		Cut and tie them off for Tiptronic vehicles.
2	Starter connections	2	Disconnect battery	
3	Injection valve connections	3		Cyl. 6 = blue; Cyl. 5 = brown; Cyl. 4 = white
4	Connections for oil pressure sensor	2		
5	Connection for switch-over valve on the secondary air pump	1		For vehicles without a secondary air pump, fasten the connection with a tie-wrap; otherwise pull out the adapter plug (No. 6).
6	Connection for secondary air pump	1		For vehicles without a secondary air pump, fasten the connection with a tie-wrap; otherwise pull out the adapter plug (No. 7).
7	Connections for generator	3	Disconnect battery	Make sure the cable sleeves are installed correctly.
8	Connection for fan belt monitoring	1		If present, pull off adapter No. 5.
9	Connection, hall sender in the distributor ignition	1		
10	Connections for ignition coils	4	Disconnect battery	
11	Outside temperature sensor connection	1		
12	Connection, switch-over valve	1		
13	Connection, switch-over valve	1		
14	Connection for heating ballast resistor	2		
15	Connection for fresh-air blower	1		
16	Injection valve connections	3		Cyl. 3 = blue; Cyl. 2 = brown; Cyl. 1 = white
17	Connection, switch-over valve	1		
18	Engine wiring harness connecting plug	3		

97-1 page 4**97 52 55 Replacing the wiring harness for the naturally-aspirated engine**

993-Sauger

Printed in Germany, 2002

911 Carrera (993)

Wiring

97

No.	Designation	Qty.	Removal	Installation
19	Connection, switch-over valve	1		
20	Ground point	1		
21	Oil temperature sensor connection	1		

Remove the wiring harness for the engine

Caution!

Danger of material damage if the vehicle is raised incorrectly!

Raise the vehicle at the prescribed jacking points!

1. Raise the vehicle at the specified jacking points onto a platform lift.

Caution!

Risk of damage!

- **The battery must be disconnected when working on electrical components.**
2. Disconnect battery. Before disconnecting the battery ground cable, read out the fault memory using the PST II tester and find out the radio code.
 3. Raise vehicle and completely remove the underside panel.
 4. Remove right warm air pipe. To do this, unscrew the center fastening screw using a Allen key and unscrew the bolts in the strut. Then release the left and right hose clamps.

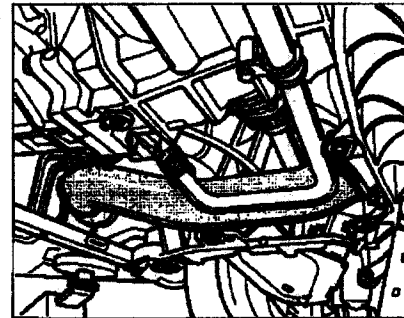

97

Wiring

911 Carrera (993)

i **Note!**

Point 5 only applies to vehicles with manual transmission.

5. Pull out reversing light switch connector. To do so, pull back the rubber sleeve and pull out the 2 connecting pins.

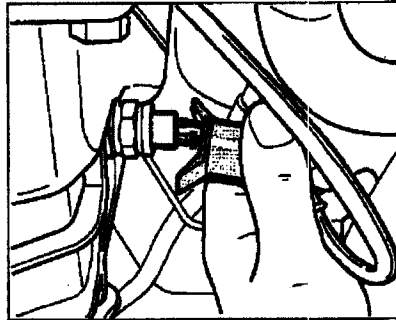

6. Remove the starter connections. To do this, loosen the two fastening nuts.

7. Cut through the two tie-wraps which is used to fasten the wiring harness on the starter.

8. Lower the platform lift and disengage the accelerator. Clasp the accelerator on the upper end and pull it forcefully to the rear until the connecting rod audibly disengages.

9. Disengage the accelerator cable in the passenger compartment. Remove the foot mats in the driver's footwell. Then unscrew the 3 cross-recess screws from the wooden board.

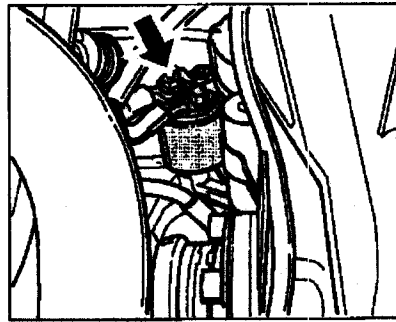

- Detach the wooden cover plate above and lift it from below until it is horizontal. Move away from the pedals in this position and remove the cover plate.

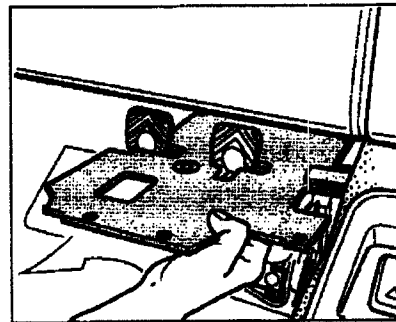

10. Disengage the lower accelerator cable on the deflection lever. ▶ To do this, pull the retaining pin **-A-**, and pull it out in the direction of the accelerator cable **-B-**. Then press off the accelerator cable from the ball head.

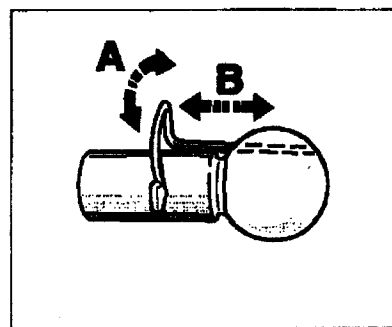

View shows the accelerator cable ▶

 **Note!**

Count the revolutions of the ball socket and record this, so that the accelerator cable won't have to be readjusted.

11. Unscrew the lock nut of the ball socket and then screw together the ball socket of the accelerator cable and the lock nut from the accelerator cable.

12. Remove intake pipe on the fresh-air blower. Unscrew the 2 sheetmetal screws on the intake pipe.

13. Remove fresh-air blower. To do this, pull off the vacuum hose, ▶ plug connections for the switch-over valve, and the fresh-air blower. Then release the hose clamp and the 2 fastening screws, and remove the fresh-air blower.

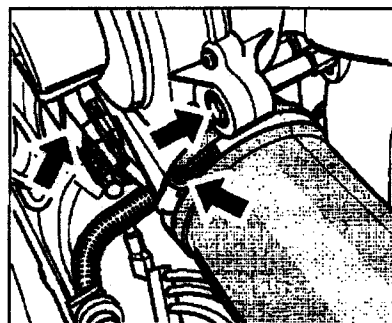
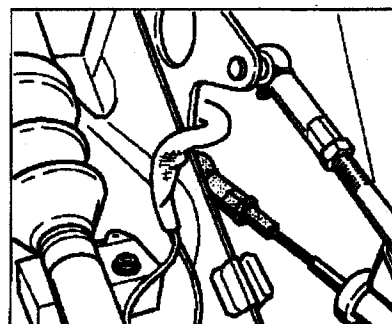

14. Disconnect the plug connection ballast resistor on the heating pipe and clip in the ballast resistor again. ▶

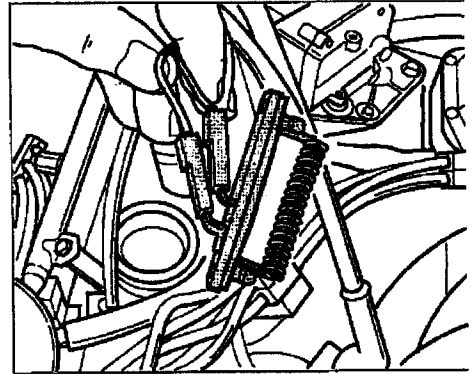

15. Disconnect the 3 plug connections and take the wiring harness out of the holder. ▶

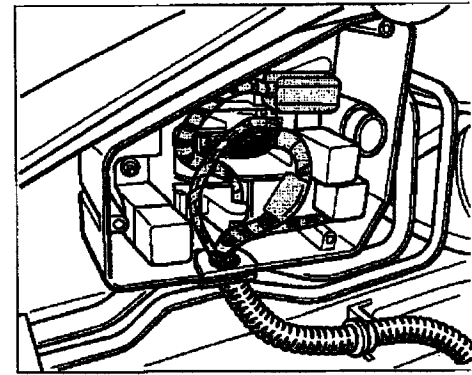

16. Disconnect the following plug connections on the holder, in the front left part of the engine compartment: reference mark sender (black), temperature sensor (white), knock sensor (green), and the cruise control connection. Then release the vacuum hose and rubber hoses and pull them off. ▶

- 1 - Temperature sensor, connector color is white
- 2 - Knock sensor connection, connector color is green
- 3 - Reference mark sender connection, connector color is black
- 4 - Cruise control connection, connector color is black

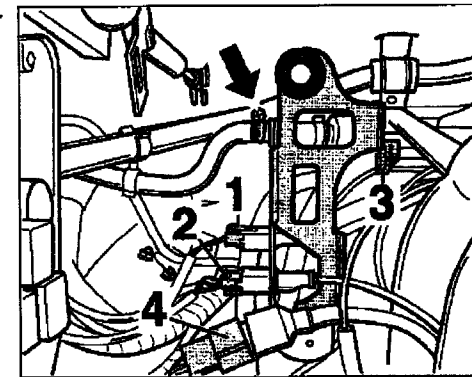

17. Release the holder for the air-conditioning lines.

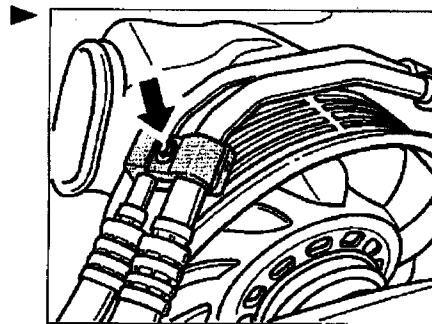

18. Remove air cleaner: Pull off the rubber hose of the transmission venting. Release the upper fastening screw of the air cleaner housing. Open the 2 fastening clips of the air filter cover and take the cover with the air filter element out of the engine compartment.

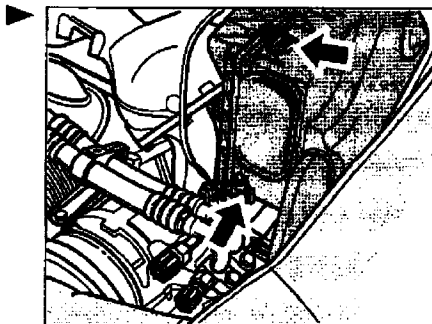

19. Remove air flow sensor. To do this, insert the flexible socket wrench (SW 7) above the intake system and release the hose clamp on the air flow sensor.

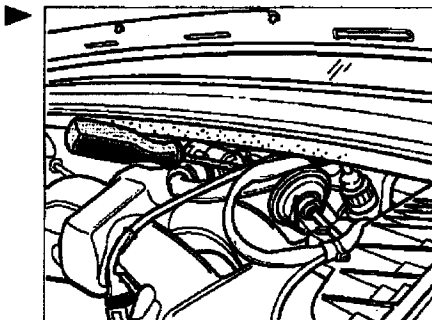

20. Disconnect the air flow sensor from the air cleaner housing. Take the air cleaner housing out of the rubber mounts rearward and downward. Disconnect the air flow sensor from the air cleaner housing by turning. Disconnect the plug-in connection of the air intake temperature sensor, take the air cleaner housing and air flow sensor out of the engine compartment.
21. Disconnect the green plug connection of the knock sensor to the right and to the rear. To do this, press the locking stirrup and pull off the connector. Take the connector out of the holder.

22. Remove air-conditioning compressor. To do this, release the lock nut on the adjusting screw, and unscrew this approx. 1 turn. Remove the black plastic cover right on the body and disconnect the plug connection. Then release the 4 fastening screws and set the connected air conditioning compressor on suitable base.
23. Remove the intake cowl of the cooling fan. To do this, release 3 fastening screws (M6 x 16) and remove the intake cowl.

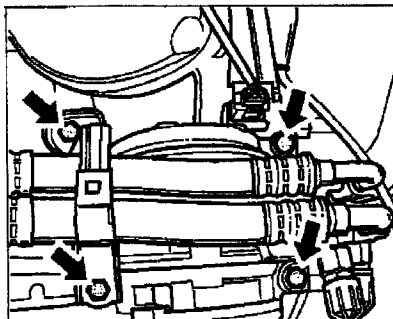

24. Removing fan belt monitoring. Pull off the plug connection of the fan belt monitoring and unscrew the fastening screw. Remove the fan belt monitoring.

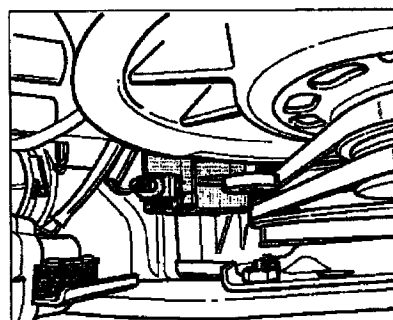

25. Disconnect the positive crankcase ventilation hose. Release the hose clamps of both positive crankcase ventilation hoses leading to the throttle body on the front ride side in the engine compartment and remove the positive crankcase ventilation hoses.

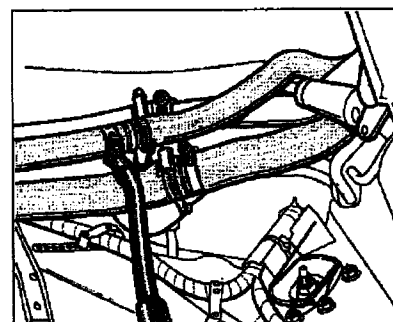

Note!

For vehicles equipped with cruise control, the linkage of the cruise control on the servo motor must be pressed down before the intake system can be taken out of the engine compartment.

26. Pull off the vacuum hoses to the left on the intake system. Then pull off the plug connection of the switch-over valves to the left on the intake system. Disconnect the connector on the idle speed control.

27. Release the intake distributor. To do this, release the upper hose clamp on the intake pipes with a flexible screwdriver (SW 7), lift the intake system, and pull it lightly to the rear out of the engine compartment.
28. Detach the accelerator cable on the throttle body and thread it out of the holder.
29. Close the intake pipes with a clean, lint-free cloth.
30. Take the intake system out of the engine compartment.

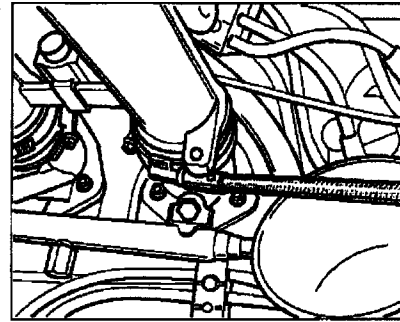

31. Release the cooling fan. To do this, unscrew the fastening screw of the restraining strap and tilt the cooling fan to the rear.

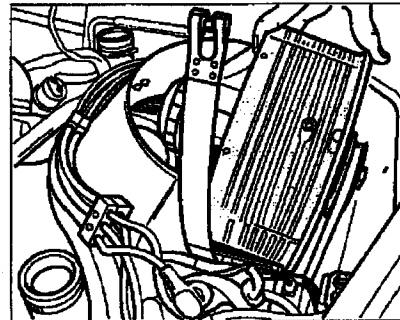

32. Disconnect the generator connections. Unscrew the 4 fastening screws on the front cover of the generator and remove the cover. Then remove the 3 connections of the generator.

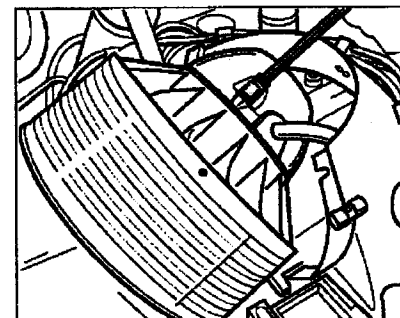

33. Disconnect the wiring harness to the ignition coil. To do so, pull off the lead (terminal 4) to the distributor ignition and remove the rubber caps.

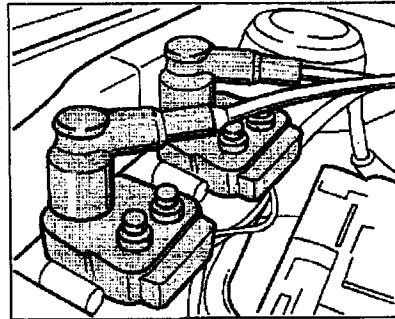

– Then unscrew the 4 fastening nuts of the electrical connections and remove the leads.

34. Disconnect the hall sender plug connection on the distributor ignition.

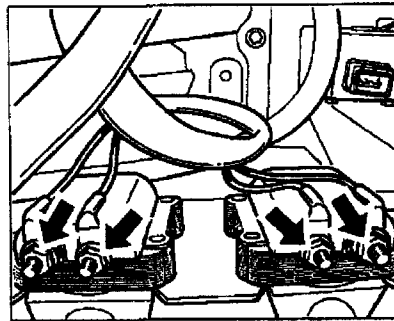

35. Release the ignition wire retainer. To do so, unscrew the 2 fastening screws with a crosshead screwdriver. Then unclip the fastening clip on the restraining strap of the cooling fan.

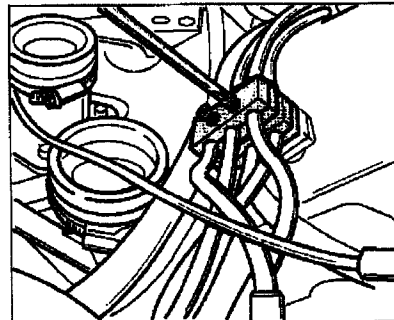

911 Carrera (993)

Wiring

97

36. Remove the 2 retaining clips on the fuel gallery of cylinder bank 1 - 3 and 4 - 6. ▶

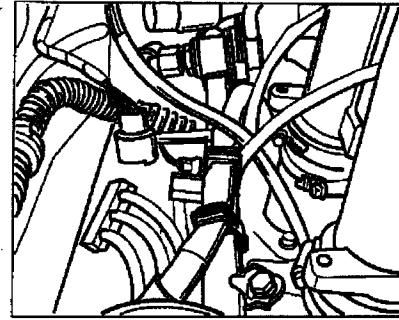

37. Disconnect the ground point. To do so, unscrew the fastening screw on the intake pipe of the 3 cylinders with an Allen key. ▶

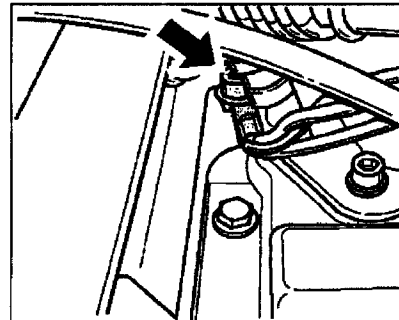

38. Disconnect the 6 plug connections of the injection valves.

39. Unscrew the holding clamps. Release the 2 fastening clamps of the wiring harness. ▶

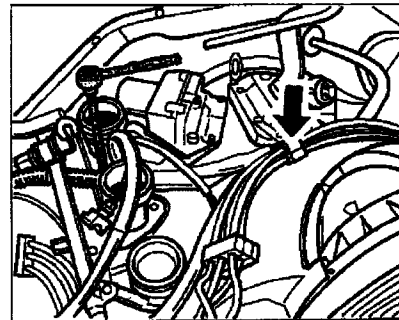
**97 52 55 Replacing the wiring harness for the naturally-aspirated engine**

Printed in Germany, 2002

993-Sauger

97-1 page 13

40. Remove the plug contacts from the oil temperature sensor and the oil pressure sensor. ▶

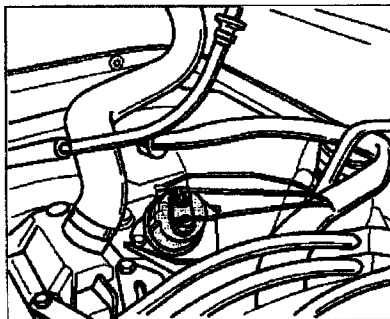

41. Pull the starter cable out of the engine paneling.
42. Pull the generator connections out of the air guide housing. ▶

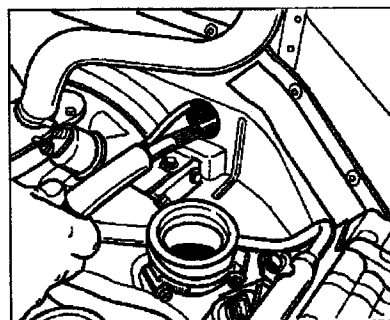

43. Pull the left half of the wiring harness under fuel gallery 1 - 3. ▶
Then take the wiring harness out of the engine compartment.

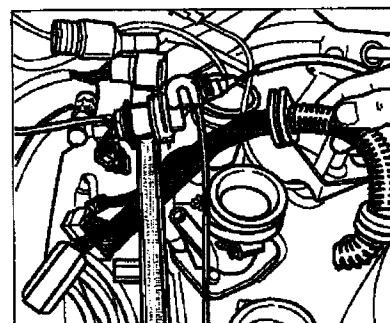

Installing the wiring harness for the engine



Note!

Check all connectors and connections of the wiring harness to see if there are rubber seals and if they are seated correctly!

 **Note!**

- ◆ The wiring harness fits multiple equipment versions. Any unused connections should be sealed with sealing plugs. If these connections should be needed, the corresponding connector must be removed.
- ◆ An unused cable should be fastened with a tie-wrap.

 **Warning!**

- **Work step No. 1 can only be carried out on Tiptronic vehicles.**

1. On vehicles with Tiptronic transmission, before fitting the wiring harness, the connecting cable for the reversing light switch must be cut off approximately 1 cm behind the orifice. Then this should be protected from moisture with insulating tape. ▶

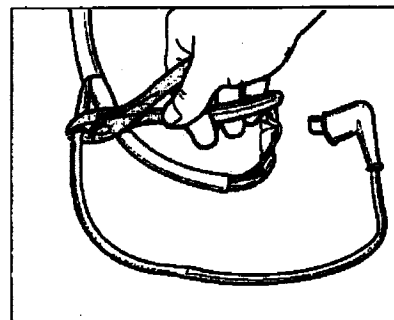

Protect the end of the lead from moisture. ▶

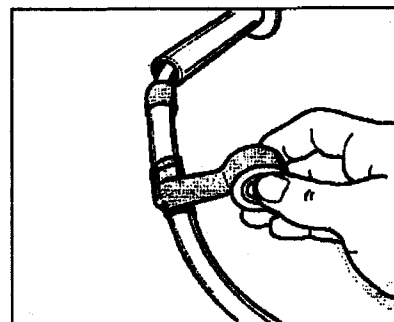

2. Place a new wiring harness on the center of the engine. Guide the side with the connecting plugs of the wiring harness between the intake manifold of the second and third cylinder under the fuel gallery. Connect the 3 electric plugs on the relay box on the left side.

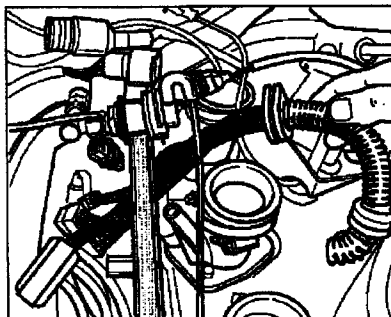

View of the relay carrier in the engine compartment.

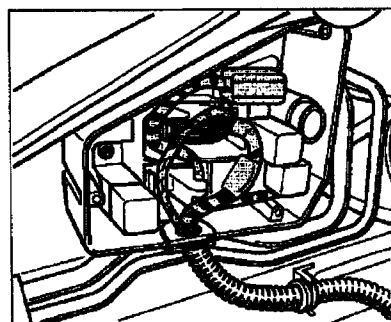

3. Press in the rubber sleeves of the wiring harness and screw down the cover with the 3 fastening screws.

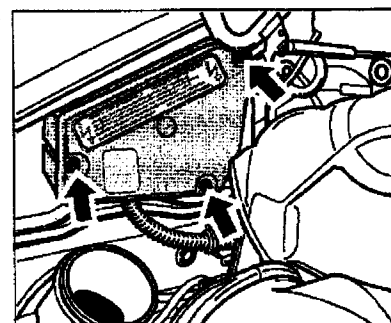

4. Tighten the ground cable on cylinder 3 to 10 Nm (7.5 ftlb.).
5. Connect the 3 injection valves of cylinder bank 1 -3.

Connector color	Cylinder
blue	3
brown	2
white	1

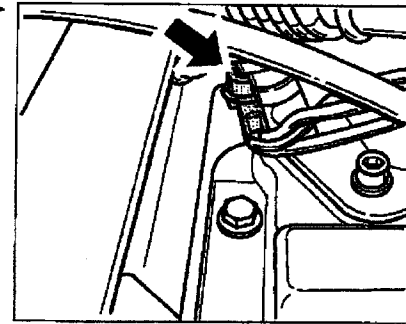

6. Fix the wiring harness leading to the fresh-air blower to the fuel gallery with the 2 fastening clips.

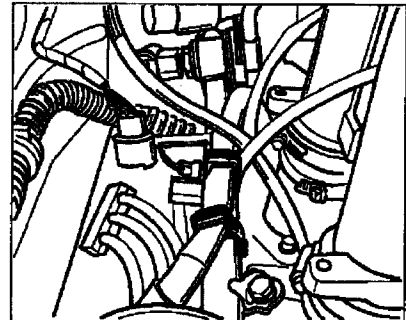

7. Lay the right side of the wiring harness in the engine compartment. Guide the lines of the reversing light switch and starter through the opening in the engine paneling. Press the rubber sleeve in the engine paneling. Ensure it is seated correctly.
8. Insert the generator cable through the opening in the air guide housing and press in the rubber sleeve. Ensure correct seating.

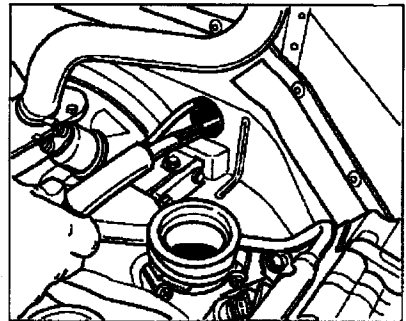

9. Connect the oil pressure sensor and oil temperature sensor. ▶

Note!

- ◆ If the vehicle doesn't have a secondary air fan, the connector for this must be fastened to the wiring harness using a tie-wrap.
- ◆ If there is a secondary air pump, pull off adapter No. 6 and No. 7.

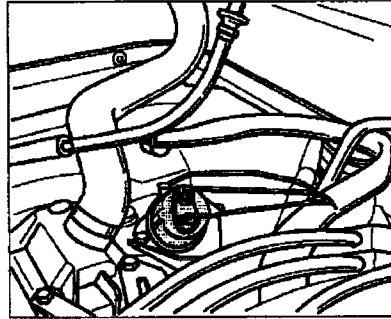

View shows the fixed connector

10. Connect the injection valves of cylinder bank 4 - 6.

Connector color	Cylinder
blue	6
brown	5
white	4

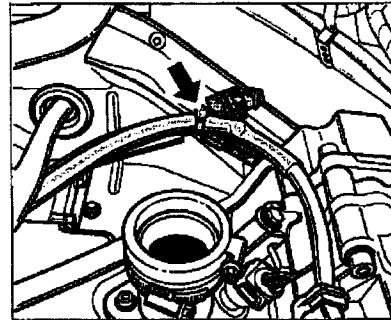

11. Tighten the left holding clamp of the wiring harness with an Allen key (M6 x 32 screw) and the right holding clamp with a hexagon wrench (M6 x 15 screw) to 10 Nm (7.5 ftlb.). ▶

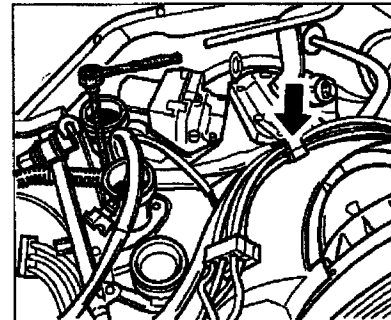

12. Connect the generator. Connect the 3 cables of the generator again. The D+ cable (blue) is tightened to 2 Nm (1.5 ftlb.), the D- cable (brown) to 2 Nm (1.5 ftlb.), and the B+ cable (red) to 8 Nm (6 ftlb.). Then press the rubber sleeve in the cutout and put on the rear closure cap. The 4 fastening screws are tightened to 10 Nm (7.5 ftlb.).

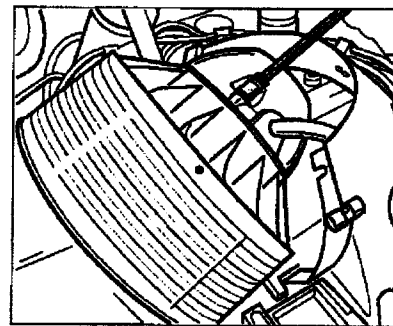

13. Move the wiring harness holder on the lines of the ignition coils under the holder of the ignition lines and tighten the 2 cross-recess screws. Then clip in the fastening clip on the restraining strap of the engine fan.

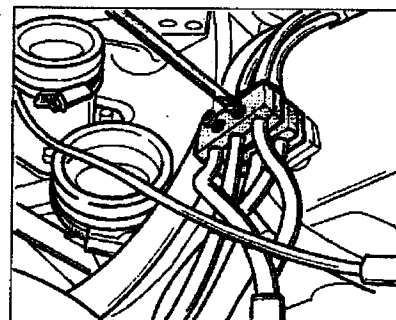

14. Connect the two ignition coils and tighten the M5 fastening nuts to 5 Nm (3.8 ftlb.) and the M6 fastening nuts to 8Nm (6 ftlb.).

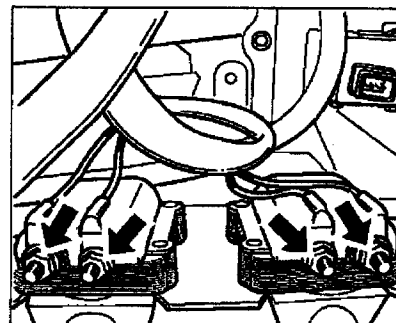

15. Fit rubber caps on the ignition coils and then connect the ignition lines to the distributor ignition.
16. Connect the hall sender plug connection on the distributor ignition.

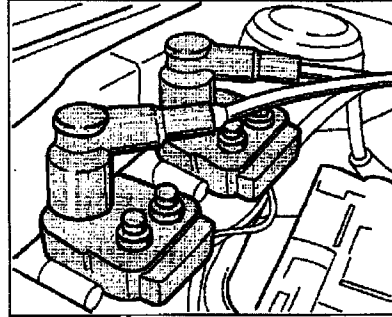

17. Position the cooling fan again. Swivel the cooling fan back in the installation position and mount the restraining strap using a M6 x 70 hexagon socket head bolt. The screw is tightened to 8 Nm (6 ftlb.).

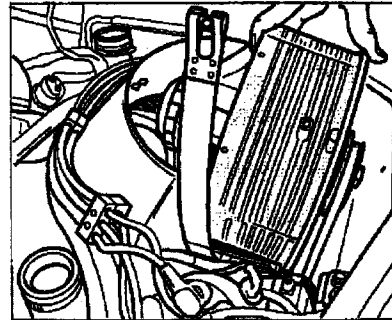

18. Install fan belt monitoring. Mount the fan belt monitoring with a M6 x 30 hexagon socket head bolt. Tighten the screw to 10 Nm (7.5 ftlb.). Then connect the plug connection.
19. Remove the cloth from the intake pipes.
20. Place the intake system in the engine compartment.
21. Insert the accelerator cable into the holder and engage it. Pay attention to the correct position of the rubber sleeves.
22. Connect the vacuum hoses and connect the plug connections of the switch-over valves to the left side of the intake system. Subsequently push on the connector of the idle speed control.

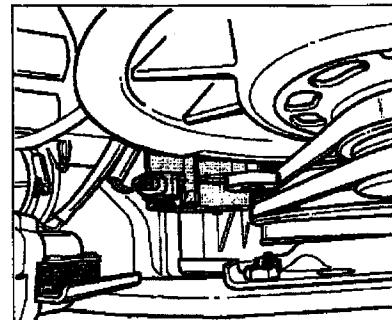

 **Note!**

On vehicles equipped with cruise control, the gas linkage on the servo motor must be press in again.

23. Put the intake distributor in the installation position and tighten the 6 upper hose clamps of the connecting sleeves with a flexible socket wrench (SW 7). Connect the connector on the idle plug.

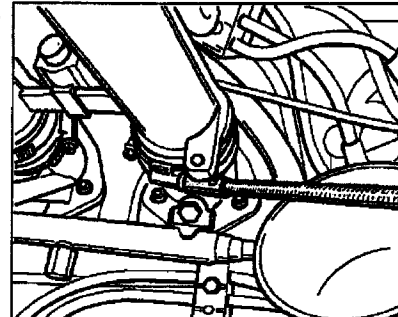

24. Tighten the positive crankcase ventilation hoses. Join the 2 positive crankcase ventilation hoses on the right front side of the engine compartment and tighten the hose clamps.

25. Install the green plug connection of the knock sensor in the sheetmetal bracket in the rear on the right and join the plug.

26. Connect the intake cowl of the cooling fan and install it with 3 fastening screws (M6 x 16). Tighten the fastening screws to 10 Nm (7.5 ftlb.).

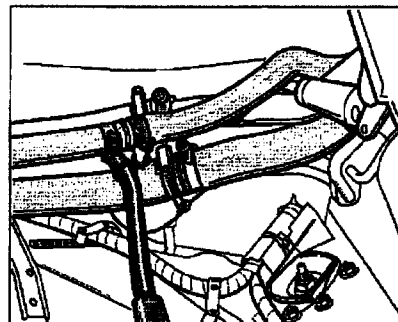

27. Install air-conditioning compressor. Put the air conditioning compressor with its slots in the installation position and tighten the 4 fastening screws slightly. Then tension the drive belt in accordance with regulations and tighten the 4 fastening screws to 28 Nm (21 ftlb.). Lock the adjusting screw. Join the plug connection on the right front side of the engine compartment and install the black plastic cover.

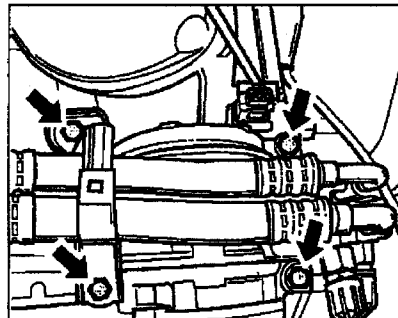

28. Install the holder for the air-conditioning lines using a M5 x 34 screw and tighten to 5.6 Nm (4.2 ftlb.) ▶

29. Install the air cleaner housing and air flow sensor. To do this, join both parts in the engine compartment and twist the air flow sensor clockwise. Place the plug connection on the air flow sensor and press in the air cleaner housing down into the 2 retaining eyes.

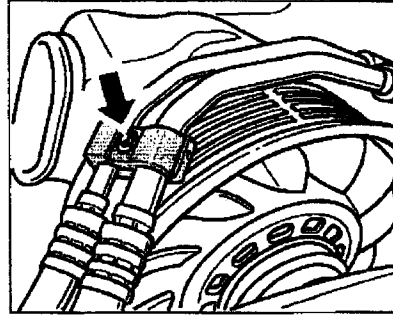

30. Tighten the rubber sleeve between the air flow sensor and the throttle body again. To do this, insert the flexible socket wrench (SW 7) above the intake system and tighten the hose clamp. ▶

31. Connect the air hose for air pre-warming to the air cleaner housing. Then tighten the upper fastening screw (M6 x 40) to 10 Nm (7.5 ftlb.).

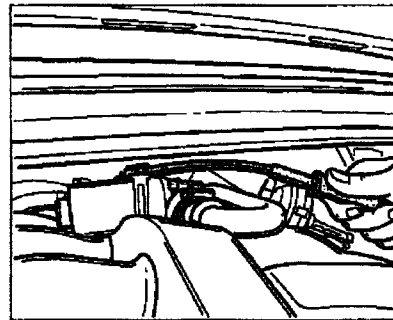

32. Insert the air cleaner element and mount the air cleaner cover. ▶

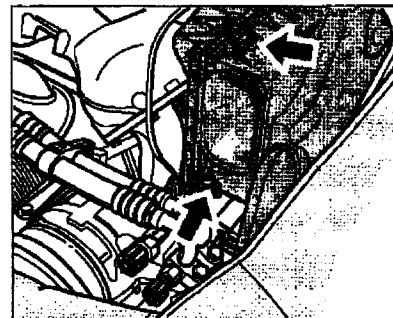

33. Install and join together the plug connections, reference mark sender (black), temperature sensor (white), knock sensor (green), and if present, the cruise control in the sheetmetal bracket. Then install the vacuum hose and the rubber hoses.

- 1 - Temperature sensor, connector color is white
- 2 - Knock sensor connection, connector color is green
- 3 - Reference mark sender connection, connector color is black
- 4 - Cruise control connection, connector color is black

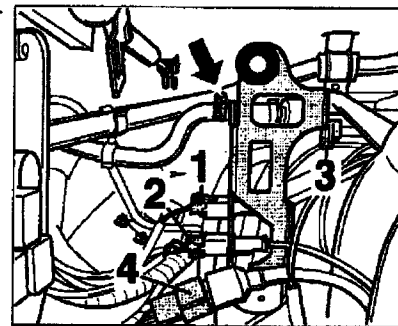

34. Connect the ballast resistor to the heating pipe and clip it in.

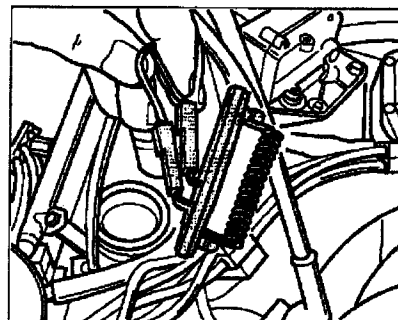

35. Install the fresh-air blower. Connect the plug connections of the switch-over valve and the fan. Connect the vacuum hose and tighten the 2 fastening screws (M6) to 10 Nm (7.5 ftlb.). Mount the hose clamp.

36. Mount the intake pipes on the fresh-air blower and tighten the 2 sheetmetal screws.

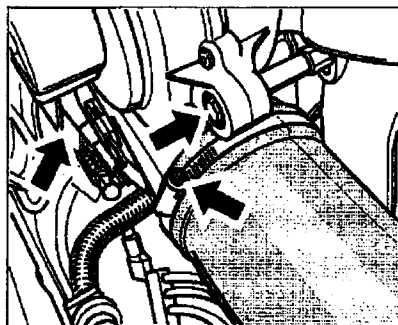

37. Move the platform lift up and connect the starter.
38. Fasten the plastic protective tube with 2 tie-wraps to the starter.

Note!

For Tiptronic vehicles, the cable for the reversing light switch must be cut off and mounted on the wiring harness with insulating tape.

39. Connect reversing light switch. To do so, insert the 2 pins and mount the rubber protective cap.

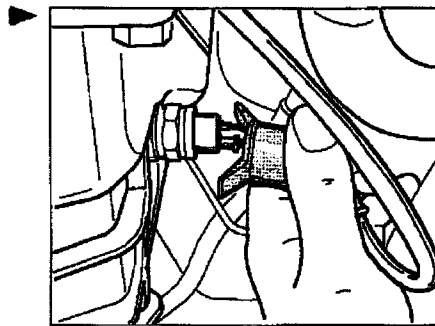
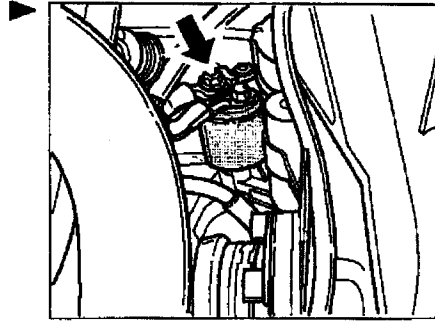

40. Install the right warm air pipe again. To do so, tighten the 2 fastening screws (M6 x 20 in the center, M6 x 12 in the strut) to 10 Nm (7.5 ftlb.). Subsequently tighten the 2 hose clamps.
41. Insert the accelerator cable in its guide sleeve.
42. Move the platform lift downward. Then install the lock nut and the ball socket. The ball socket is screwed on the number of turns that were counted when it was removed. Then tighten the lock nut.

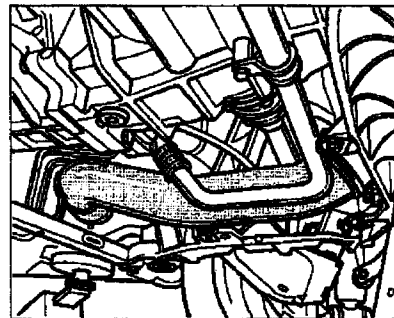

43. Then press the ball socket on the lower ball on the deflection lever and install the cotter pin. To so do, insert the pin in direction **-B-** in the bore in the ball socket and clip it around the ball socket **-A-**.

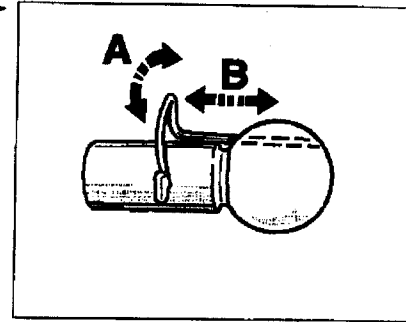

Fitted accelerator cable

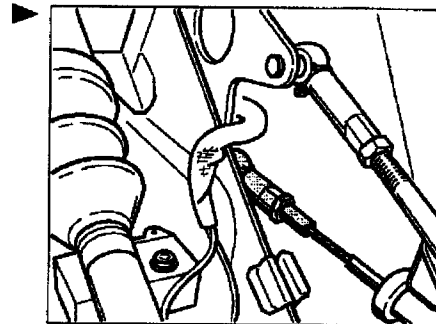

44. Move the wooden cover plate horizontally onto the pedals and press upwards into the sheetmetal bracket. Then fold down the cover plate and install the 3 cross-recess screws. Reinstall the foot mats.
45. Press the ball socket of the accelerator pedal on the ball rod. The accelerator pedal must lock with an audible click.
46. Check the routing of the accelerator cable on the underbody and install the underside panel.
47. Connect battery. Enter the radio code and clear the fault memory.

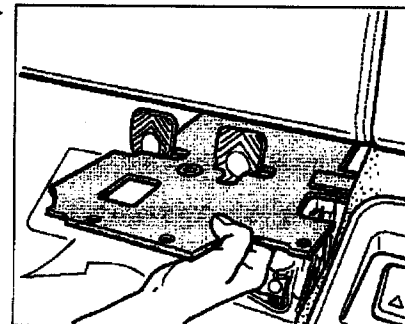

Tightening torques

Location	Thread	Tightening torque [Nm] (ftlb.)
Ground cable on the third cylinder	M6	10 (7.5)
Holding clamps for wiring harness	M6	10 (7.5)
Generator cable D+ (blue)	M5	2 (1.5)
Generator cable D- (brown)	M5 x 10	2 (1.5)
Generator cable B+ (red)	M8	8 (6)

Location	Thread	Tightening torque [Nm] (ftlb.)
Ignition coil fastening nuts	M5	5 (3.5)
Ignition coil fastening nuts	M6	8 (6)
Restraining strap on engine fan	M6 x 70	8 (6)
Intake cowl on engine fan	M6 x 16	10 (7.5)
Air-conditioning compressor	M8	28 (21)
Holder for air-conditioning lines	M5 x 70	5.6 (4)
Installation of air cleaner on the intake system	M6 x 40	10 (7.5)
Fresh-air blower fastening screws	M6	10 (7.5)
Installation warm air pipe	M6	10 (7.5)
Starter terminal 30		15 (11)
Starter terminal 50		6.5 (5)