

OBD-1 Later 1995 993

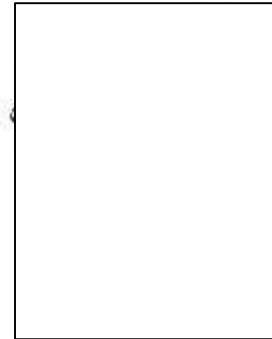

And here are the pinouts as seen on the vehicle:

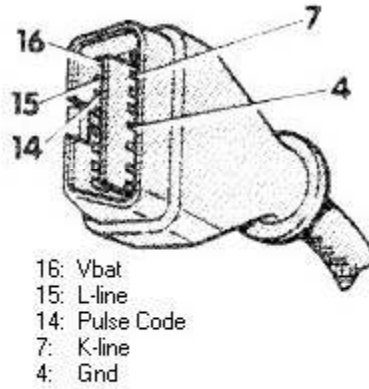
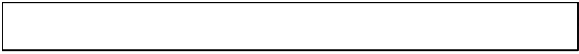
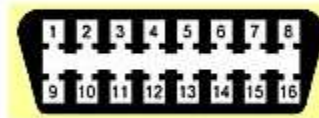

Chamber	Allocation	Description
1	nc	
2	nc	reserved [+] SAE J1850
3	reserved	vehicle bus (ODB-II DV)
4	Output Earth	VAG1551/2 and OST
5	Signal Earth	Spesification for OST
6	nc	
7	K-line	VAG1551/2 and OST
8	nc	
9	nc	
10	nc	reserved [-] SAE J1850
11	reserved	vehicle bus (ODB-II DV)
12	reserved	screen (ODB-II DV)
13	nc	
14	Signal Code	VAG1551/2 LA
15	L-line	VAG1551/2 and OST
16	U_bat	VAG1551/2 and OST

K'=CCU/ABS/SRS/ALARM

0 Volts

"K" = DME

Knock pulse

"L" = Wakeup
+12 Volts

OBD-1 EARLY 1995 993

Check adapter lead 9288/1 for continuity
Check K and L wire on adapter lead 9288/1 for continuity.

Socket 3 (8-pin connector) to pin 7 (19-pin connector)
Socket 7 (8-pin connector) to pin 8 (19-pin connector)

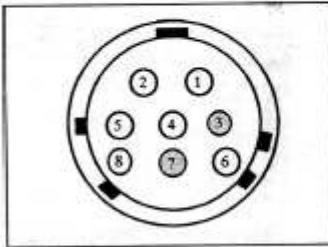

Connector on tester

0211-02

Socket 3 = L wire

Socket 7 = K wire

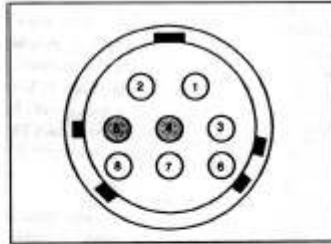

Connector on tester

1203-02

Socket 4 = Ground

Socket 5 = Terminal 15