

## Basic Use of KT Setting Tool

This tool uses a bubble gage mounted to the rear brake caliper mounting bolts to set the kinematic toe at the rear suspension of the 993. Essentially this adjustment is setting or checking rear castor. The factory calls the values SKE or scale units. This refers to their bubble gage readings. The critical part is adjusting the KT eccentrics such that the readings on the bubble gage are identical on the left side vs. the right side of the car. The factory race car KT settings were simply maxed, max rear castor. Setting the KT to #4.5-5.0 on the gage is preferred, again, more importantly is that the left and right sides are set as close to each other as possible. Eccentric "C" on the image below is the KT Toe adjustment point.

In my experience, common signs of mis-adjusted KT Toe include strange handling behavior, unsettled feeling at the rear over rough roads especially when cornering as well as extreme high rates of rear tire wear.

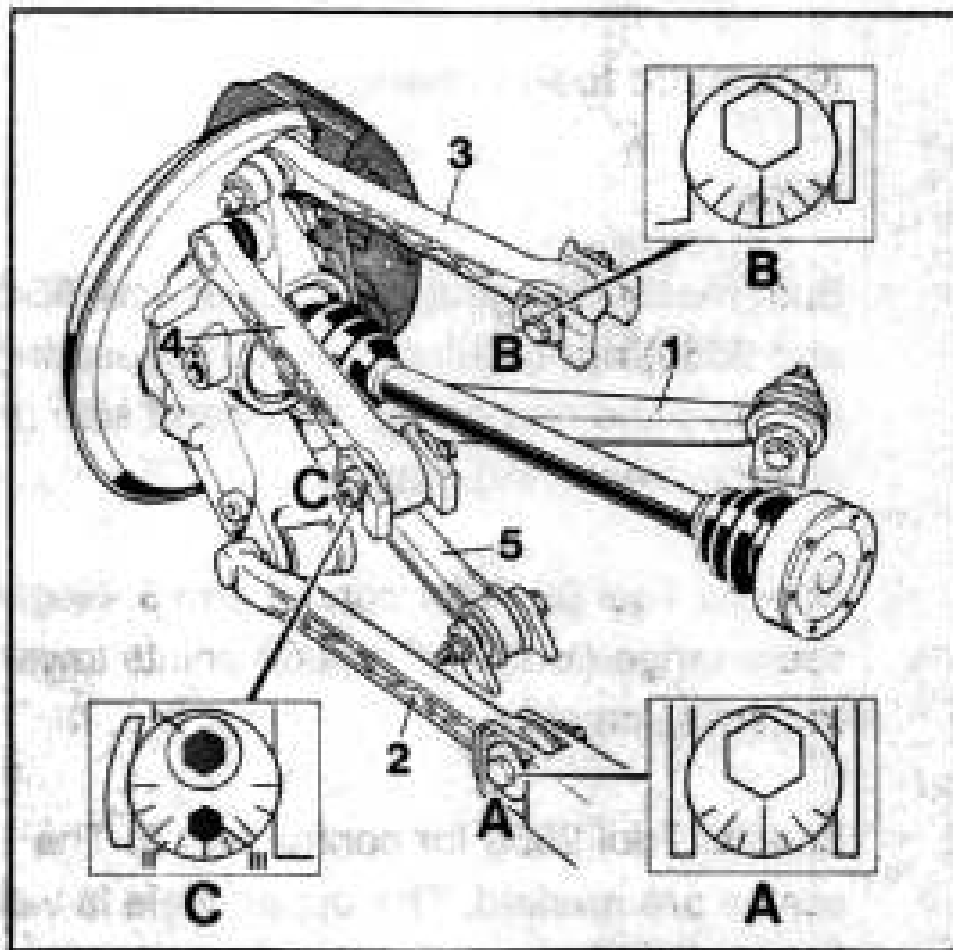

## Notes on Setting Kinematic Toe (KT):

- The use of the caliper mounted KT tool is needed when used on lowered 993's -the factory tooling will not work on cars with low ride heights - example image of this tool installed:



- I see many 993's where alignment folks mistake the KT adjustment for camber adjustment. While this may achieve the desired camber setting, it will throw-out the KT setting.
- The starting position of the KT eccentric "C" setting should be the bolt hex head clocked at the 11 o'clock position on the left side of the car, the mirror opposite (at 1 o'clock) at the right hand side of the car – these settings are near where these cars left the factory at. See image below.
- Adjust KT eccentric to achieve as close to identical readings as possible.
- Re-measure rear camber and static toe settings afterwards.

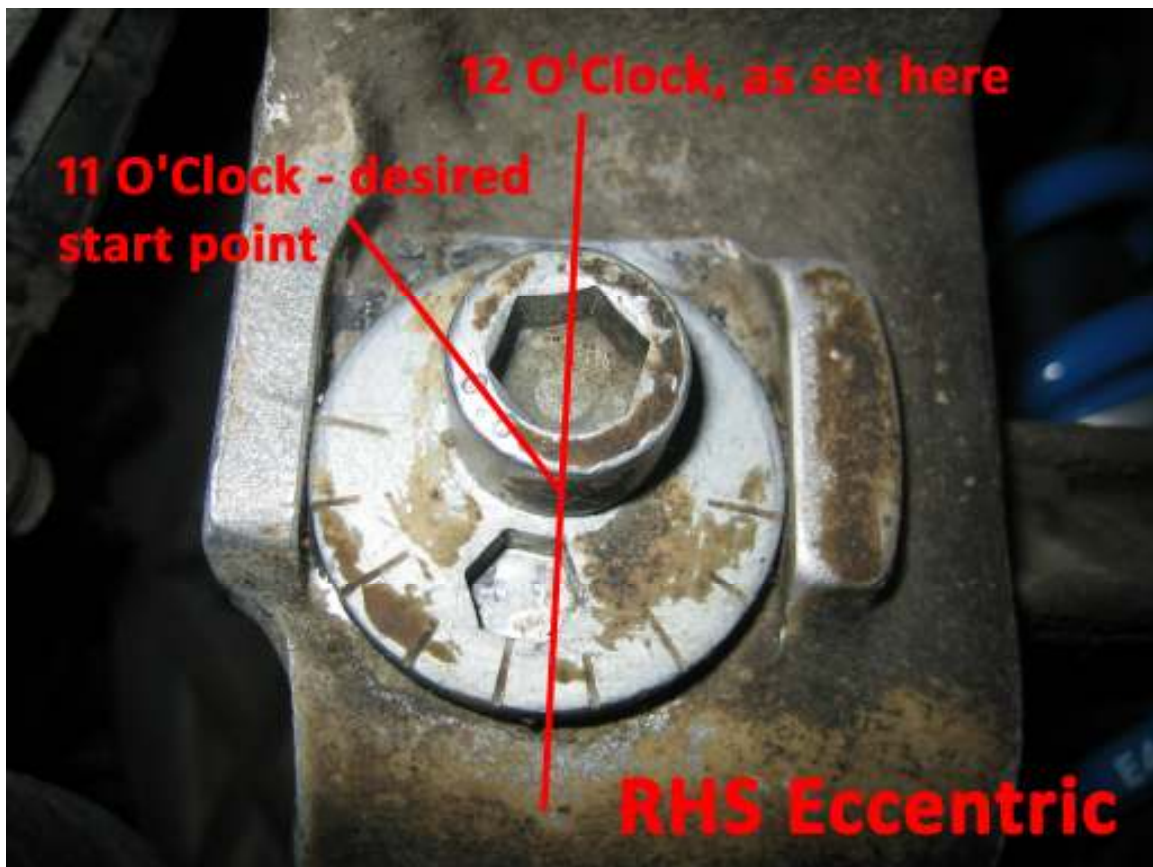

## Information from the shop manual for reference:

**Adjusting sequence (to be observed by all means):**

**1. Toe-in.** Adjust at control arm 2 – eccentric **A**.

**2. Camber.** Adjust at control arm 3 – eccentric **B**.

**3. Kinematic change of toe-in.**

Adjust at control arm 4 – **area C**. To adjust, mount the Special Tools (measuring gauges) 9549 and 9550 to control arm 2 and control arm 5 (page 44-14).

Adjust at control arm 4 – area C – at eccentric washer II.

I = Mounting bolt

II = Eccentric washer

III = Hexagon socket for rotation of eccentric washer no. II.

## Suspension values

The following specifications refer to the curb weight to DIN 70020. This means: Fuel tank full, spare wheel and tools in vehicle.

Differing settings for U.S. vehicles are given in brackets.

Carrera RS versions: M002 = basic version / M003 = Clubsport version

Information on alignment of the Carrera RS: Page 44 - 19 ff.

### Front axle

	RoW: Standard (USA: Standard)	RoW: Sport (USA: Sport)	Carrera S / 4S RoW (Carrera S/ 4S USA)	Carrera RS M002/M003
<b>Toe, unpressed (total)</b>	+ 5' ± 5'	+ 5' ± 5'	+ 5' ± 5'	+ 5' ± 5'
<b>Toe difference angle</b> at 20° steering lock	- 1° ± 30' (- 40' ± 30')	- 1° 45' ± 30' (- 40' ± 30')	- 1° 45' ± 30' (- 40' ± 30')	- 1° 27' ± 30'
<b>Camber</b> (with wheels in straight-ahead position)	- 20' ± 10'	- 20' ± 10'	- 20' ± 10'	- 1° ± 10'
max. left-to-right difference	10'	10'	10'	10'
<b>Caster*</b>	5° 20' + 15' - 30'	5° 20' + 15' - 30'	5° 20' + 15' - 30'	5° 20' + 15' - 30'
max. left-to-right difference	15'	15'	15'	15'

## Suspension alignment settings

The following specifications refer to the curb weight to DIN 70020. This means: Fuel tank full, spare wheel and tools in vehicle.

Differing settings for U.S. vehicles are given in brackets.

Carrera Rs versions: M002 = basic version / M003 = Clubsport version  
 Information on alignment of the Carrera RS: Page 44 - 19 ff.

### Rear axle

	RoW: Standard (USA: Standard)	RoW: Sport (USA: Sport)	Carrera S / 4S RoW (Carrera S / 4S USA)	Carrera RS M002/M003
<b>Toe per wheel</b>	+ 10' ± 5'***	+ 10' ± 5'***	+ 10' ± 5'	+ 15' ± 5'***
max. left-to-right difference	10'	10'	10'	10'
<b>Camber</b>	- 1° 10' ± 15'***	- 1°10' ± 15'	- 1°10' ± 15'	-1°20' ± 10'
max. left-to-right difference	20'	20'	20'	20'
<b>Kinematic toe-in change</b> max. difference between steering arm angle 2 and steering arm angle 5	1.5 SKE*	1.5 SKE*	1,5 SKE*	1,5 SKE*

## Wheel geometry

### Notes

Check and adjust wheel adjustment values only when the specified requirements are met (page 44 – 9, General).

If the wheel alignment is measured at the front and rear, start by checking and adjusting the rear axle.

For specifications, refer to p. 44 - 4 / 44 - 5. Tighten nuts and bolts to the specified torque after adjustment. For tables, refer to Repair Groups 40 and 42.

### Rear axle

Prepare the car for checking and adjusting the wheel alignment values. Place front wheels on rotary tables etc. Jounce vehicle and rear and front axle 2 or 3 times and let the springs return the car to its normal height.

**Adjusting sequence (to be observed by all means):**

1. **Toe-in.** Adjust at control arm 2 – eccentric **A**.

2. **Camber.** Adjust at control arm 3 – eccentric **B**.

3. **Kinematic change of toe-in.**

Adjust at control arm 4 – **area C**. To adjust, mount the Special Tools (measuring gauges) 9549 and 9550 to control arm 2 and control arm 5 (page 44-14).

Adjust at control arm 4 – area C – at eccentric washer II.

I = Mounting bolt

II = Eccentric washer

III = Hexagon socket for rotation of eccentric washer no. II.

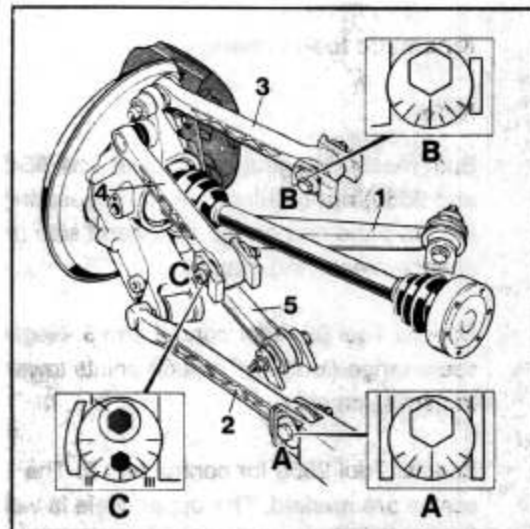

### Adjusting toe-in

With the underbody paneling removed, turn eccentric A as required.

If **only the toe-in** has to be corrected (camber o.k.), the kinematic toe-in change **does not** have to be checked.

### Adjusting camber

Remove cover of control arm 1/5 (bottom control arm). Rotate eccentric B as required. To undo the lock nut, use Special Tool 9558 in conjunction with a torque wrench. Use Special Tool 9557 to lock at eccentric B.

If the camber setting has been corrected, the kinematic toe-in change will have to be checked as well.

When tightening the lock nut with Special Tool 9558, **observe the following: 85 Nm (63 ftlb.)** at the lock nut corresponds to a setting of **approx. 65 Nm (48 ftlb.)** at the torque wrench.

## Kinematic toe-in change

### Note

Both measuring gauges (Special Tool 9549 and 9550) are required both for measuring on the left-hand and on the right-hand side (interchange measuring gauges).

Special Tool 9549 for control arm 5. Negative scale range (long end of tool) points towards transmission side.

Special Tool 9550 for control arm 2. The scales are marked. The upper scale is valid for the left-hand side of the axle, and the lower scale is valid for the right-hand side of the axle.

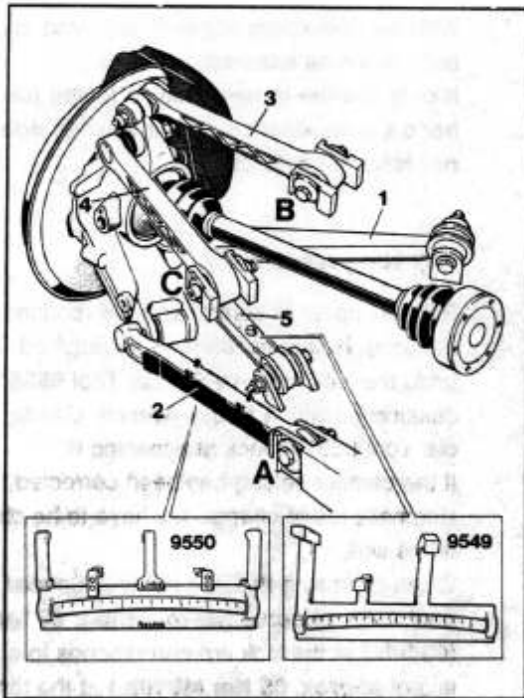

1445A-44

Check **cover of control arm 2** for correct fit. When no excessive force is applied, the cover must not shift by more than 10 mm (move to the left and right by applying only light force). Replace cover if required. Trapezoidal end of cover (arrow) must point towards wheel side.

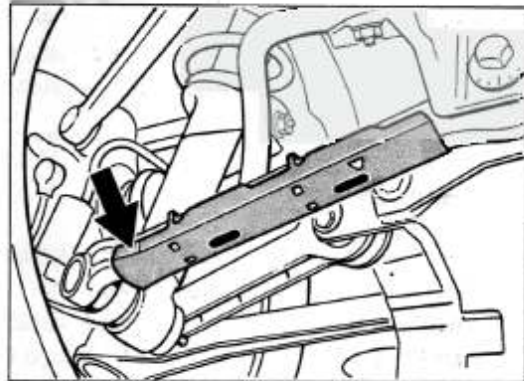

1463-44

Mount **Special Tool 9550 to control arm 2** (measuring surfaces must be free from dirt). 2 cutouts in the control arm cover help to locate the Special Tool correctly (refer to fig. 1463-44).

Center out cover (move to the left and right without applying any force).

Then locate cover in the center position and continue by centering out Special Tool 9550 as well. This prevents the measuring gauge from entering the radius range of the control arm (arrow no. 2) as this would give an incorrect measurement reading.

Also make sure the measuring arms (arrows No. 1) are in perfect contact with the control arm.



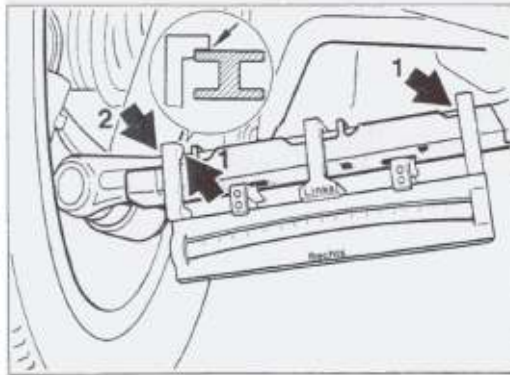

1446-44

Mount **Special Tool 9549** to control arm 5 in such a manner (measuring surfaces must be free from grease) that the negative range of the scale (long end of tool) points towards the transmission side.

Start by placing tool against the support point (support lug) on the wheel side. The inner measuring arm must contact the control arm (arrow). If required, straighten spring on Special Tool somewhat.

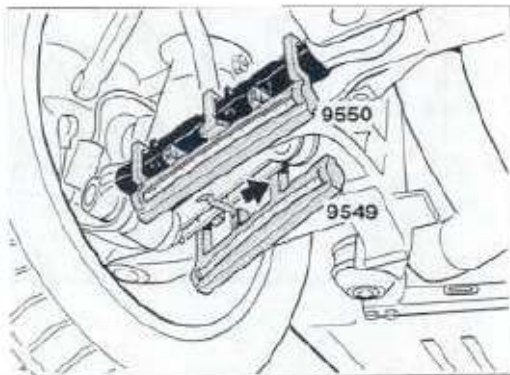

1447-44

Read off figures on both Special Tools. Both figures may deviate from each other by **not more than 1.5** scale units.

**Measure and read off at the center of the bubble level.**

If required, align both bubble levels (numerical values) with each other. **In this position, the kinematic toe-in change is adjusted correctly.**

Adjust at control arm 4 (caster control arm / refer to fig. 1445A-44).

To adjust, turn the eccentric washer after undoing the fastening bolt (area C).

When adjusting the kinematic toe-in change, make sure the **camber values remain within the admissible tolerance range.**

Fit Special Tool 9549 and 9550 to the **opposite side of the rear axle.**

Proceed with measurements and adjustments on this side of the axle as described above. Special Tool 9549 is mounted to switchover position while the orientation of Special Tool 9550 remains the same as on the opposite side of the axle.