

Things to consider when Buying /
Servicing / Replacing / Upgrading a
993.

Copyright © 2017 by Andrew Hess All rights reserved. No part of this publication may be reproduced, distributed, or transmitted in any form or by any means, including photocopying, recording, or other electronic or mechanical methods, without the prior written permission of the publisher, except in the case of personal use by members of the Rennlist.com web Forums and brief quotations embodied in critical reviews and certain other noncommercial uses permitted by copyright law. For permission requests email Andrew Hess at andrew.hess@differentlight.biz

9/19/2017

Andrew

Things to consider when Buying / Servicing / Replacing / Upgrading a 993.

Contents

Disclaimer:	4
IF Items as in "if not done yet or by"	4
• Clutch	4
• Secondary Air Injector (SAI) Pump	4
• 1st & 2nd gear synchros	4
• Differential repair	4
• Steering rack rebuild	5
• Replace power steering	5
• Replacement of hydraulic lifter cartridges	5
• Replace ignition wires	5
• Replace plugs	5
• Replace rotor & cap	6
• Replacing an oxygen sensor	6
• Replace Strut cartridges and or springs	7
• Saving your bumper covers from grounding damage	7
• Replace suspension bushings	7
• Brake Pads & Rotors	8
• Replace Internal distributor belt	8
• Replace Odometer gears	9
• Cleaning the Idle valve	9
• Cleaning the air flow sensor	10
• Fixing insidious, power robbing, vacuum leaks –	10
• Rerouting the clutch vent pipe	11
• Door check strap fix	11
• Door seal repair	12
• Oil Filler Bellows Removal	12
• Check engine light	12
• Air Injector Pump Check Valve Replacement	13
• Excessive Oil Consumption	13
I change my own oil.	13
Oil Leaks	14

Things to consider when Buying / Servicing / Replacing / Upgrading a 993.

• Dual Mass Flywheel	15
• Alarm light on door	16
• HVAC Servo Motors	16
Minor inspection items:.....	17
• High mounted tail light	17
• Airbag light.....	17
• High mounted stop light not working	17
• Horn Honking.....	17
• Turn Signal flashing too fast --	17
• Window up/down switch.....	17
• Replace the car audio speakers	18
• Car Seat removal –.....	18
• To Sub-Woof or not, that is the question	19
• Leg Room –	19
• Hard back sports seat leather	19
• Removing nasty old rear fender guards.....	19
• Lately having a car “wrapped” is all the rage in the media	19
• Making those calipers shine like new	20
• Ignition Lock.....	20
Emergency Essentials:	20
• Junk in the Frunk.....	20
• Belts	20
• Key & Fob.....	21
• Battery Not Charging	22
• Battery Status & Charging.....	22
Safety Upgrades:.....	22
• High Intensity Discharge Headlights (HID),	23
• Automatic door locking.....	23
• Wheel Nuts	23
• Adding an emergency engine release cable –.....	24
• Door Panel Wrap.....	24
• Shift Boot Cover	24

Things to consider when Buying / Servicing / Replacing / Upgrading a 993.

• Gauge Trim Rings	24
• Making Modern 12 Volt Accessories fit in the old oversize cigarette lighter	24
• Adding Cup holders	25
• Adding Heated Seats	25
• Cleaning up the look of the engine bay –	25
• Replacing seat upholstery -.....	25
• LED Marker/Turn/Stop lights	25
Body fluids	26
• Oil.....	26
• Fuel System Cleaner	27
Other notes:.....	27
• On Board Diagnostic connections	27
• OBD Code Ignition Faults	27
• Getting meaningful OBD Code information from your reader	27
• Kinematic Adjustment	27
• Turn signals & dead batteries	28
• Battery Bumpers:	28
• The Cabin Pollen Filter	28
• Underbody Covers	29
Inspecting a car for purchase:	29
• Mail-order Brides	30
• CarFax	30
• Salvage titles	30
• Leak Down Testing	30
• Body & Paint Work.....	31
• Why Paint Matters	31
• Painting a new vs used bumper cover -	32
• A quick mirror paint gouge fix:	33
• Impact damage	33

Things to consider when Buying / Servicing / Replacing / Upgrading a 993.

Disclaimer: I am not a professional automotive technician and some of the opinions expressed in this document are just that, opinions therefore please feel free to use this document at your own risk. Many times a lot can be learned by simply watching a qualified professional work on your 993:

IF Items as in “if not done yet or by” – or if symptoms exist, many of the items, below can be done at home with basic tools:

- **Clutch** - IF not done once in the past. All sorts of shifting issues can present when a clutch is at the end of its life including slipping on acceleration, a hard to actuate clutch even dinging gears when shifting. A 993 should shift as easily as a Honda Civic. If this is not your experience have it looked at.
- **Secondary Air Injector (SAI) Pump** - While the clutch is out inspect wiring that leads to the SAI pump where it attaches to a connector on a bracket above the air pump. These wires are known to suffer insulation failure and are easier to replace when there is access to the back of the engine.
- **1st & 2nd gear synchros** – IF the gears tend to grind slightly while shifting especially in cool weather when the car is cold. Grinding is a sound and feel of the system slipping over multiple synchro teeth with every shift into a specific gear. This is not a common occurrence, just an experience I had. If the gears exhibit a single ding or two when cold that is mitigated by slightly slower shifting and it disappears completely once the tranny warms up this seems to be normal for many of these cars as the transmission ages. However if the gears grind and the problem only gets worse with a gear lubricant refresh it is a dead giveaway you have this issue. This was an 80K+ odometer item for me.

I have read endless circular discussions on Rennlist concerning shifting feel and various brands and viscosities of gear lubricant. My view is as the synchronizer friction rings become worn their ability to grip and synchronize the gears is diminished very very gradually over many many miles of use. At some point their ability to grip is so tenuous that very small changes in lube viscosity or temperature can result in significant differences in shifting acceptability. At this point I feel looking for a gear lubricant one likes better may not be the answer. The transmission may simply need to be serviced and have its worn synchros replaced. On the up side, unlike earlier 911s the 993 does not require the engine to be removed to service the transmission.

- **Differential repair** – When the transmission is open for synchro replacement on a base model Carrera one of the gears on the differential may exhibit some chips missing from its face. Any shop that does a reasonable amount of Porsche transmission work will have a used or repaired standard differential on hand. This is because many times when a previous customer upgraded to a limited slip differential the shop retained the original. These parts may be available at a very low cost to you. I have an unsubstantiated theory that when a base Carrera is pushed to the point of wheel spin, at the point where the tire reestablish grip it jackhammers the standard differential gears and may be the cause of rather large steel gouged chips from the gear face showing up at the transmission lubricant drain plug.

Things to consider when Buying / Servicing / Replacing / Upgrading a 993.

- **Steering rack rebuild** - IF leaking - inspect with the under body cover off; a little weeping of the fluid at the rack ends is OK as the end boots really do not seal very well and even less so with age. Substantial dripping on the underbody cover suggests an established leak. If it has gone to the point where you must top off the reservoir it is an indication that your steering rack is a candidate for a rebuild. This seems to be somewhat of a chronological age related issue. It is likely accelerated by corrosion on the rack rod ends as the inside tie-rod end boots lose their sealing ability and road moisture & debris can get inside the boots contaminating the rack. Replacing the inside tie-rod boots may forestall this issue to some limited extent. Here are some comprehensive notes on removing and installing the rack on Rennlist.com "[Steering rack replacement notes](#)"



There are significant service life advantages to sending in your own rack for a rebuild rather than accepting a swap-out from the rebuilders' inventory of racks. See Rennlist.com posting "[Steering rack replacement notes](#)" also see p-car.com's posting "[How to jack the car up safely](#)" safely, remember As the French say "to die for love" is a good thing however I think they are speaking of this while under something other than a car!

(Send out rack for rebuild, remove & install yourself on jack stands, very messy two session job - one day to pull the rack, a week later a day to put the rebuild back in.)

- **Replace power steering belt** - IF not done once in past I had mine done at 80K miles when I was having the clutch replaced, a skilled technician can replace this belt without removing the engine or transmission;
- **Replacement of hydraulic lifter cartridges** - IF noisy, sounds like a bucket of ball bearings rattling around, at startup after sitting for a day or two; if car sits for an extended period such as a month and the sound presents on the first startup but disappears thereafter and does not return on a subsequent restart this is a sign that the lifter cartridge seals may leak a bit but have not progressed to the point where cartridge replacement is indicated. This seems to be a chronological age related issue as the cartridge seals lose elasticity and slip off causing the cartridges to no longer retain their oil or proper function at initial start-up. This issue presented for me about the same time as the need for clutch replacement at 80k miles on my car. To replace them involved removing the valve covers and presents the opportunity to replace the valve cover seals, plugs and wires at the same time incurring minimal additional labor to do so.
- **Replace ignition wires** – Ignition wires are a long wearing, some have needed to replace them in as little as 60K miles others much much longer. If your car is not throwing misfire codes, you are not experiencing ignition problems in wet weather and the wire ends look good you can probably hold off on replacing them as a preventative maintenance item. However if your car has over 60K miles on it and you will have the engine out or the valve covers off for other reasons the incremental labor to replace them should be low and so replacing them may be considered.
- **Replace plugs** - Plugs are generally extremely long service life items on a 993. I would not replace them unless your car has miles in excess of 80K and you are having the engine out or its ancillaries removed for other reasons as replacing the plugs alone is labor intensive. If you do not have a diagnostic misfire code attributable to worn plugs avoid the temptation to mess with them. If you do



Things to consider when Buying / Servicing / Replacing / Upgrading a 993.

have such issues check the cap & rotor first then the ignition wire involved as these are more common reasons for such codes. A non-cylinder specific or multiple concurrent cylinder specific misfire codes are usually not caused by a wire, plug or injector and is more likely related to systemic issues like a vacuum leak, a dirty idle valve or an oxygen sensor out of specification. By the way it is OK to replace just one ignition wire or plug as needed.



- **Replace rotor & cap** – IF there is a concern about rough idling. 993 does not exhibit a perfectly smooth idle so what is normal is learned with experience. My experience is that if one starts from cold a 993 without giving the engine a little throttle blip once started it may settle down in a very slow uneven idle. In this situation it may even illuminate the check engine light and throw a random misfire code. The solution to this is to clear the code and move on.

I found that caps and rotors seem to be a two to three year repeat item on my car. If I leave them longer at some point I get a check engine light and a reoccurring random misfire diagnostic code that keeps coming back when cleared. So about every two years I have been replacing the caps and rotors on my engine. Recently I tried 1500 grit sandpaper to polish the carbon tracks off the rotor and I hosed out the inside of the distributor caps with CRC Electric Motor cleaner. This seems to have done the trick extending the life of the parts somewhat. I for some reason kept some of the old caps and rotors, and now I have a lifetime supply of two year old rotors and caps that can be put back into service if needed. On one occasion I got a check engine light and upon inspection found one of distributor caps was a little loose. I tightened it up and the light went out shortly thereafter. Even though the caps are plastic and I do not want to distort or crack a cap I will need to make sure the distributor cap screws are a bit tighter in the future, a bit beyond lightly hand snug.

- **Replacing an oxygen sensor**– The 993 has four oxygen sensors. The sensors measure oxygen content before and after the two catalytic converters and are integral to the emissions and mixture adjustment functions of the engine. They only work properly when heated up. Over time they accumulate deposits that slows the time it takes to warm into their operating range. After X number of start-ups where the time to heat was in excesses of Y seconds the OBDC system will light the check engine light and present an oxygen sensor slow to respond code. Not very surprisingly, this seems to happen to most owners in the fall when the weather is a little cooler and the sensor warm up period is extended by a few seconds. The fix involves simply clearing the code and seeing if it comes back any time soon. Think of the money you will save by not unnecessarily replacing all four of your sensors one or more times over several years. At some point you may receive an OBD Code indicating the sensor or its internal heater is dead or in combination with other code suggesting it is too far out of specification to do its job. At this point it needs to be replaced.

My 96' had three of its original four sensors up until 100K miles on the odometer. By the way replacing a sensor in most cases is a very easy DIY job. The secret to removing a stuck sensor is to cut the wires leading to it and slip a closed end box wrench over its mounting hex. Using such a wrench in combination with a little penetration oil on the mount over-night should allow one to pop the sensor loose. New sensors come with anti-seize applied. If your replacement sensor doesn't have any use a little on the sensor's threads using care not to contaminate the tip of the sensor.

Things to consider when Buying / Servicing / Replacing / Upgrading a 993.

- **Replace Strut cartridges and or springs** - IF car bounces on rebound while driving, the suspension sits low or seems harsh on brick or cobblestone roads. Most of our cars have replacement (upgraded) aftermarket struts already that are good-to-go as is. If the aftermarket struts the previous owner put on your car are H&R or Bilstein (most common brands) and sometime in the future need replacement, they can be rebuilt at a substantial savings over buying new – saving potentially \$1500 over a new set. Come to think of it this is a very good reason to replace with one of these two brands in the first place. Many US cars have had their **springs** swapped out with aftermarket springs early in their life to lower the suspension to a more sporting height. Over time these aftermarket springs can sag. Replacing struts, springs or both as a complete coil-over kit is a surprisingly easy job done with jack stands and one of these: “MacPherson Strut Spring Compressor Set” transforming the ride of the car. Also see p-car.com’s posting **“How to jack the car up”** safely. An inexpensive height adjustable coil-over option I have had great daily driver results with for the last several years is the **H&R Street Performance Coil-Over kit** 29954-1 on hrsprings.com , both springs and matched struts for all four wheel-ends, cost < \$2000 if you shop around, I got mine on e-Bay. This kit allows for setting the ride height from the USA specification down through the ROW range, -30mm on to a greatly lowered height where other suspension component geometry limits come into play. You can reuse the existing rear anti-sway bar down-links with this kit under normal height ranges. The only additional parts you will need for the job are 16 replacement M8 lock-nuts (900.380.005.09) for where the strut mounts attach to the body at the top. Lots of aspiring track guys buy kits with adjustable valving for a considerable premium over this kit, to each his own I say.
- **Saving your bumper covers from grounding damage.** - The rear bumper cover on the 993 has a forward facing lip. Over time I have had the experience of damaging my bumper cover on my home’s high driveway apron where the front edge of the cover grounds, digs in and is pulled back tearing the bumper cover, ouch! With a lowered car this can also happen on speed bumps or most any uneven pavement threshold. My DIY solution avoiding this issue was to create a 2”+/- wide crescent shaped sheet metal guard that is attached so it sits under the cover’s edge but is not attached to it. On my car where I no longer use the OE under engine pan it is held in place via straps made from copper plumbing tube. The straps are attached to the two transvers exhaust mounting clam studs using flange nuts. At his point it has saved me an expensive body repair on four or five occasions. Making such a guard is an easy DIY project involving some HVAC duct sheet metal and some copper tubing purchased at a local DIY store. In the above picture the guard is bright metal. I have since painted it black with high heat black spray paint. In either case it is only visible from under the car. I see no reason why a similar simple sheet metal guard mounted over the front bumper cover beneath the car would not protect the plastic cover from grounding as well. Could be a fun Saturday morning project!
- **Replace Tie rod ends** IF play is present - IF only the end boots are cracked just replace the boots. See: **“Energy Suspension Tie Rod End Dust Boots ”** on summitracing.com. Simple tool to do this at home; See **“Tie Rod and Pitman Arm Puller”** on Harborfreight.com 
- **Replace suspension bushings** - IF car does not feel tight after a known good alignment the bushings should be evaluated for play.

Things to consider when Buying / Servicing / Replacing / Upgrading a 993.

- **Brake Pads & Rotors** – The 993 comes with a check-your-brakes warning light. One of the reasons the light comes on is when a sensor clipped to one of the brake pads is ground down to the point that it becomes an open circuit. On my car I soldered the sensors wires together and tie-wrapped them out of the way against the struts. If one visually inspects their brake pads every 30K miles or so, something that happens yearly here in VA due to mandated state safety inspections, there is no need for the sensors.

Pads need to be replaced when the friction material looks to be thinner than the backing plate. Pads worn to the minimum or rotors running near their maximum wear limits tend to contribute to greater instances of brake squeal on the 993. Replacing the brake pads can be done with the calipers in place or removed. Replacing the pads is relatively easy however Porsche specifies that if you remove the front calipers you must use new bolts to remount them. I do not know why this is needed but Porsche wouldn't specify this unless they saw a failure in a test so I just do it. Taking the pads out is easy however one needs to use a 1" metal paint spatula to slice the squeal silencers, sometimes call spiders, off the pads backing plate so the pads can be removed.

Some replace the spiders when installing new pads some don't. My experience is that if one uses the relatively soft OE dealer pads and replaces the spiders it will minimize the occurrence of brake squeal. When installing new pads without removing the caliper I find putting the spiders in first and peeling off their backing plate adhesive covers before guiding the new pads into position seems to be the way to go. Once the brakes are cycled for the first time the adhesive will be pressed firmly against the pad.



Also I also find slightly grinding off the inside curved edge of the new pads friction material helps in it having the clearance to slide into position. OE supplier to Porsche drilled rotors can be purchase on-line at Rock Auto at a surprisingly affordable price. If you took the calipers off to replace the pads one need only remove one rotor hold down screw to replace the rotors.

The screw is best removed with a manual impact screw driver, an inexpensive tool



purchased at Harbor Freight. I always paint the contact surfaces of the rotor to the hub and the hold down screw with anti-seize when mounting rotors as it will make the rotors easier to remove in the future. Same goes for the wheel mounting contact points on the rotor face.

- **Replace Internal distributor belt** - IF by 80K miles it has not been done once in the past; A broken belt can cause significant consequential damage to the engine so checking for a working belt should be done regularly on all cars and any time you perceive a change in engine performance, idle or other ignition issue. I do a quick check once a year just to be on the safe side. To test just unplug the directly driven distributor's center coil wire. The directly driven distributor is the one where the base of the distributor bolts to the engine case. If the car starts and runs at all with only the belt driven distributor's coil wire attached the belt is in place, if not it is most likely broken. If the belt is found to be broken and you must drive the car to have it serviced leave only the directly driven distributor's coil attached to minimize the risk of out of timing cylinder detonation damaging the engine. It may be advisable to periodically test the directly driven distributor as well as it could suffer from an ignition module or coil failure that has gone undetected. Such a failure can have an effect on the smoothness of idle and emissions.



Things to consider when Buying / Servicing / Replacing / Upgrading a 993.

Removing and shipping your distributor off for servicing yourself is a surprisingly easy thing to do. To make room to remove the Distributor detached the center coil distributor wire only on each distributor cap and tie the caps with the plug wires attached clear of the work area. I only removed the lower duct from the blower and the upper duct part that vents out of the engine compartment grill very little prep work involved. I also took a reference picture of the rotational position of the gear driven rotor using care to be directly above it and thereby not introducing a perspective error that would misinform concerning its fully seated position.

Once the hand brake is applied, the transmission put in neutral for the duration of the replacement, the distributor caps and distributor hold down nut are removed and the distributor is ready to come out I used the crow bar placing the bar's heel on the engine case below the distributor as the fulcrum point and the crow bar's claw on the bent end of the bar against the underside of the distributor where very light force is applied next to the drive shaft driven rotor housing.

It took very little force to break the O-Ring's initial resistance for removal. I then took a 2nd picture pulling the distributor out just beyond where the drive gear slid off its engagement inside the engine recording the offset of the rotor caused by its disengagement with the drive gear. I used the 2nd picture to reposition the rotor when reinserting the distributor once serviced.

Be aware there are only two shops that get consistently high marks for rebuilding this part on Rennlist, Mark Cohen (770.365.1601) of Powder Springs, GA & Steve Weiner at Rennsport Systems (<http://rennsportsystems.com/>). Be sure to tape a piece of hose over the drive gear to protect it for shipment. Other rebuilders seem to have problems getting the correct bearings, washers and other small parts that may be needed. I also understand that the major cause for a rebuild redo is the previous improper installation of a bearing on a previous servicing. Seeing that this is likely a once in the ownership life of the car who needs the aggravation of using an untested source of rebuilding.

- **Replace Odometer gears** - IF odometer is not working or if not done once in past. The advantage of doing this repair as a preventative fix is you won't have to fish around and find the tiny broken gear teeth that if not found can jamb the mechanism once it is reinstalled. This seems to be an age related issue as two of the plastic internal gears become brittle, easy kitchen table project. See "[How to repair a broken odometer](#)" on p-car.com.
- **Cleaning the Idle valve** – IF not done in the last 30K miles or the engine seems to idle roughly. The idle valve should never need replacement, just spray-out cleaning until the valve internals rotate freely when you gently rotate the unit with your wrist. See "[993 Idle Stabilizer Valve \(ISV\) Cleanout](#)" on p-car.com. When cleaning my car's valve I use Carb & Choke petroleum based solvent cleaner. I also clean the electrical plug and socket with CRC electronic/electric motor cleaner as carb & choke cleaner is not intended for plastic electrical connectors.



For future reference one can write the date and miles once cleaned right on the valve housing, using a sharpie pen. I tend to mark down this information when replacing ancillary items whenever possible. For routine items such as rotors, caps and oil changes I make a sharpie pen note on the underside of the engine lid and clean it off and update it with new information when I revisit the procedure.



Things to consider when Buying / Servicing / Replacing / Upgrading a 993.

- **Cleaning the air flow sensor** - IF not done in the last 60K miles or so. It must be cleaned with a Q-tip in conjunction with "CRC Mass Air Flow Sensor Cleaner" just spraying it out will not always release the grey debris coating on the sensor element, the element when clean looks like a white circuit board. See Rennlist posting: "Mass Air Flow Sensor MAF Cleaning does it work?" . If when removing the sensor the element looks clean, cleaning it will not improve its functionality, it may best be replaced.
- **Fixing insidious, power robbing, vacuum leaks** – When one of the vacuum actuators, three on the non-Varioram and five on Varioram Cars, or any of the rubber hose connectors fail (leaks) or slips off they can cause a rather large air intake leak. Since any leak is down stream of both the mass air flow sensor & the throttle body, no good can come from this as a good size vacuum loss can cut horsepower significantly.

I checked one of the, now 19 year old, actuators by disconnecting it and sucking on the air line that feeds it, lots of air draw, no movement. Interestingly what seemed to be a rather large vacuum leak did not throw an OBD code on my car. I ordered three 993.110.462.02, and one 993.110.461.03, one for on the top passenger side of the engine, one connected to heater blower ductwork, one on the driver side underneath the Varioram intake manifold and fourth actuator on the intake manifold similar to the others but with a longer actuating arm.

A fifth actuator that can cause a power loss is located behind the Climate Control Unit (CCU) in the dash connected to a ventilation flap. The actuator is a metal can style one and looks to be rather robust. Porsche sells it as a complete vent unit but I bet, if leaking, an inexpensive metal can style actuator purchased on eBay could be MacGyvered to replace it at low cost. I tested mine by pulling the CCU clear of the dash w/o disconnecting the CCU harness then attaching a hose directly to the actuator and drew vacuum by mouth. Once a static vacuum was applied it stayed retracted so I could infer that it was not leaking. Interestingly the actuator's arm had become detached from the vent mechanism. I replaced the missing pin with a tie wrap, probably good for at least another five years. Once reconnected to its vacuum source, I started the engine and actuated the vent flap by pressing the recirculating air button on the CCU while observing it through the dash hole. I then buttoned things up and was good-to-go, took all of ten minutes.

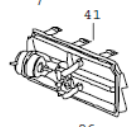

It is quite easy to test the actuators including the Varioram system on so-equipped cars, all the actuators and the solenoid valves that control them you will need a helper:

1. Have your helper start the engine and run it for a few moments, to build vacuum;
2. Shuts the ignition off;
3. Turns the ignition back on without starting the engine while you observe the engine;
4. Observe the three Varioram actuators on the engine going through an initial cycling, you will need a flashlight and push down on the rubber duct attached to the fan housing to observe the third actuator underneath the intake manifold;
5. With the ignition on press the air recirculate button on the Climate Control Unit (CCU);
6. Listen for the sound of the vacuum actuated recirculating air flap moving behind the the dash;

Things to consider when Buying / Servicing / Replacing / Upgrading a 993.

7. Go back behind the car and observe the heater flap actuator located on the duct work on the lower left side of the engine;
8. Cycle the CCU thermostat setting from cold to hot and back to cold a few times while observing the actuator;
9. Observe the actuator retracting rotating the flap arm from the 7:00 o'clock (heat) to the 9:00 o'clock (cool air) positions as you rotate the knob on the CCU.

It is probably a good idea to run the above test any time you notice an operating change with the engine.

- **Rerouting the clutch vent pipe** – It is interesting that on the manual transmission 993 there is a clutch vent pipe that runs up along the passenger side of the engine to a rubber hose that directs the venting to the pre-filter side of the engine air intake box. An emission control idea?? Seems to me this arrangement has three value-added features. First it clogs the filter with any abrasive debris that comes out of the pipe. It also allows any abrasive friction material that gets past the filter into the engine and it ensures when the clutch is not used carefully the burning friction odor is immediately piped into the engine bay and sucked into the cabin heating system adding a certain something special to the driving experience. At this point I rigged up a prototype breather that replaces the rubber hose leading to the engine air intake box. It is an easily slipped on solution made from home plumbing parts and an aftermarket automotive breather element, is completely reversible and may be of interest to some:



- **Door check strap fix** - IF making a loud “click”, “pop” or “cracking” sound when the door is opened or closed. You may have no sound but observe the strap mounting point on the A pillar shifting slightly as you open or close the door, a sign of future failure. This is a long standing 911 universal body part weakness with a relatively expensive (body shop) fix however it is very easy to avoid. There is a DIY to modify the check strap reducing forces and greatly reducing the likelihood of the check strap progressing to failure going forward. I would do this DIY modification immediately on all 993 with or without the above symptoms as eventually they all will encounter this problem. See: “[Modifying] 993 Door Check-Strap Detent Assembly” on p-car.com. Be sure to replace the old pivot pin that attaches the strap to the A pillar with a fresh one as a worn pin can be an additional source of the popping sound.



Things to consider when Buying / Servicing / Replacing / Upgrading a 993.

- **Door seal repair** – If you notice that the door seals on your car look worn where your foot passes over the threshold there is an inexpensive fix. The replacement 993 specific seal is staggeringly expensive and some find using the 964 seal can make for a tight door fit. For \$50 you can buy a door



seal made to fit earlier 1984 to 1988 Carreras. You can cut a section out of it as a donor to replace the worn section on your 993's seal. The profile is the same, on some suppliers' after-market seals the finish differs slightly, no biggie. One seal is long enough for several repair jobs. If you have a concern about joining new to old you can use a small section of vacuum or fish tank air hose slipped into the joined ends to make the mating look perfect.

- **Oil Filler Bellows Removal** – At his point it is unlikely that an oil filling bellows is still nested inside the engine oil filler neck on any 993. It originally was designed to pull out making an oil fill easier. This bellows eventually breaks down and bits of plastic can fall down the filler tube into the engine oil. On most cars this bellows was removed long ago. If you see it inside under the oil filler cap you can pull it out and throw it away. Unfortunately if it is still in place once you pull it out what debris that remains will need to be flushed out and the oil changed.
- **Check engine light** – IF the secondary air injector ports are reported as by OBCD as clogged. I have no experience with this however the previous owner of my car did. I have read antidotal notes such as it shows up more in cars that have spent most of their life in hot climates and that it is related to valve guide wear as some have asserted that the original guides are made of a slightly too soft metal. I have also read that once the valve guides are replaced the problem seems to not return. There is more than one approaches to fix this issue or simply getting the light to stay off for inspections:
 - Remove the exhaust manifold & air supply and clean the passages/ports with a wire snake made from a bicycle brake cable attached to a hand drill & flushing with cleaning solvent. With this process you will replace the check valve, some do this as a DIY project;
 - Add electronics so engine management thinks the clog does not exist, something that may not be legal as well as a disclosure issue when you sell your car, also a DIY item or;
 - Disassemble the engine to clean the ports/passages and replace the valve guides, sometimes part of what is called a top-end rebuild. The official Porsche solution, the one your friendly neighborhood automotive shop will \$love\$ to recommend.
 - Clear the OBD injector code and run through a prescribed driving procedure that triggers three of the five emissions related READY codes needed to make the car pass emission inspection in most states. Here is a how-to: [How to Legally Pass State Emission Inspection](#)

My gut tells me that by now many 993s have had their valve guides replaced, on my car it was done in-warranty years ago. If you do experience this problem first check your car's oxygen sensors as the

Things to consider when Buying / Servicing / Replacing / Upgrading a 993.

computer can't diagnose clogged exhaust ports directly but does it indirectly through the oxygen sensors. The fault may simply be caused by a slow sensor or a failed sensor heater or both. You may also be able to forestall a full-on disassembly & valve guide replacement for tens of thousands of miles if not indefinitely by engaging in one of the less invasive fixes. Be sure to read the "Excessive Oil Consumption" section below as it may give you additional insights into a potential cause and long term avoidance of this issue.

Also a bad air check valve, leaking air hose, faulty air pump, or deteriorated wires (known issue) on the back side of the engine leading to and clamped above the air pump can also cause the same light to come on. In the case of the wire deterioration I would check this any time you have access to the back of the engine for example during a clutch replacement.

- **Air Injector Pump Check Valve Replacement** - The air check valve is a pain to remove however it can be easily tested by slipping a hose over it and using your mouth to first blow and then draw air from the hose. If you can blow with some resistance but not draw it is working and need not be replaced. I shoot 5-10cc of Techron in to it to clean carbon build up in a working valve. I have no empirical proof this does anything but I do it anyway. If you encounter high resistance or simply can't blow any air or can draw air your issue may be a bad valve or clogged injectors. I would go ahead and replace the valve and do the mouth test again to validate the presence of clogged air injectors.
- **Excessive Oil Consumption** - Is another reason owners consider a top-end rebuild under the assumption that the valve guides are worn to the point that excessive oil is slipping past them and burning. The logic in this seems sound. Then again I recently ran across the following comment in the 993 Rennlist Forum in reply to an oil consumption concern:

"How full do you keep the oil tank? When I kept mine at the full level I'd go through easily a qt. per 600 miles, now I keep it at min - 1/4 I use barely a qt. every 2500 miles. Even now, after spirited driving, the oil can expand to over 1/2 full."

The implication here is that a true measure of a full oil tank is somewhat variable and overfilling may be contributing to the perception of excessive oil consumption where none may exist. Could burning the ingested oil over-fill over time explain the clogged secondary air injector ports, potentially a self-inflicted service issue caused by simply overfilling the oil? Who knows?

I change my own oil.

On level ground I drain the oil tank and the engine case, and through the right rear wheel well, I replace both filters. I do not disconnect any tubes to attempt to drain the oil in the oil lines as my belief is that breaking the seals presents unnecessary leak failure modes. I do keep a can of electric motor cleaner on hand to clean off oil spilled on the engine and suspension when removing the smaller filter.

I refill the oil tank with 8 quarts +/- of oil and run the engine to a fully warmed state looking to the temperature and oil pressure gauges to see if they have settled into their normal operating range. I then, with the engine running, add additional oil, ¼ quart at a time until the

Things to consider when Buying / Servicing / Replacing / Upgrading a 993.

oil level dash gauge settles at about midway with a fully warmed engine. I feel this method gives some additional margin of safety in avoiding inadvertently overfilling the system as well as additional status feedback as the needle is not pinned during operation but moves in relationship to how hot the oil is. The primary measurement of an oil fill is done with the dip-stick so I also look at it a well and note the position of the oil. If you decide to follow my measurement procedure and determining the fill with the dash gauge and you pull the dip stick and it is dry, it suggests your gauge is a bit out of adjustment. In such cases I would fill the oil to the mid-point on the dip stick range but not above.

Adjusting the gauge so it approximately matches the dip stick involves draining the oil accessing the oil tank float and bending its arm a little. I have done this on my 86' Carrera and have been told it is not too difficult on the 993.

If you find yourself putting more than ten quarts of oil in, you are most likely overfilling the engine. On a 993 this can have operating consequences and so an overfill should be addressed as soon as possible.

A situation I had with my 86" Carrera and now some have reported the same issue with the 993 is where untrained hands inadvertently remove the cover of the oil pressure relief valve rather than the oil drain nut on the bottom of the engine case when attempting to drain the oil. If the oil pressure release cover is replaced without first reinstalling the spring/components it covers your engine will immediately have serious lubrication issues. If you happen to open the wrong cap, and see some small parts under it, just put it back on with the parts in the same way and look for the other cap to drain your oil. If your car comes back from an oil change with the oil pressure warning light illuminated and or the oil pressure near zero stop driving the car and address the missing oil pressure valve parts that most likely fell into the oil drain pan unnoticed.

I'm going out on a limb a bit, But I feel any road driven normally aspirated 993 (Carrera) that has been used exclusively for street driving and an occasional club auto-cross should not need any internal engine work beyond replacement valve lifter cartridges until well beyond 120K miles of use. The suggestion of such a need should always be suspect and the need validated by multiple persons via multiple diagnostic methods.

Oil Leaks.

At some point in your cars life it will leak oil. The 993 engine is oil cooled and lubricated and the engine itself is an assemblage of heads, cylinders, case halves, valve covers, oil coolers, the oil tank, and the list goes on, all involving seals and gaskets. In my book the main reason to fix an oil leak is because it is dripping on the floor or it is dripping on the exhaust and smells bad. Interestingly I thought my car had two oil leaks one at one of the oil return tubes. The other appeared to be on the driver side lower valve cover dripping on the heat exchanger and smelling up the car, I am told a very common occurrence. I researched via my Rennlist friends a DIY valve cover gasket replacement and it seemed simple enough. I went ahead and purchased the new gasket. In preparation I cleaned the oil off the valve cover and the exhaust using CRC spray Electric Motor Cleaner. Afterwards the leak seemingly disappeared. Then I recalled that

Things to consider when Buying / Servicing / Replacing / Upgrading a 993.

at my last oil change I spilled oil when filling the engine. I wiped up most of it and hosed off the remainder I could see with the CRC spray. Apparently it took weeks for unseen oil to migrate to the valve cover and ultimately onto the exhaust. In retrospect I wonder how many valve cover gasket or even valve cover replacements have been done on a 993 due to a botched oil change where cleaning was all that was needed. A Porsche technician once told me that if properly installed the 993 valve covers rarely leak. He informed me that leaks are usually the result of under torquing the mounting bolts or tightening them up in the wrong order. I suspect the torque value and the tightening procedure is available from Porsche if one was to ask.

- **Dual Mass Flywheel** - This is a very very uncommon issue. - IF your car seems to idle a bit too rough and you have been experiencing:

- The check engine light and;
- A reoccurring non-cylinder or;
- Multiple named cylinder "emission relevant misfire OBDC code.

AND you have addressed the other less invasive sources of this such as:

- Run the quick, unplug-the-primary-distributor, belt test,
- Verifying there is not a vacuum leak on the engine,
- Cleaning the idle valve,
- Replacing the distributor caps and rotors and,
- Addressed any cylinder specific reoccurring misfire codes, wires, plugs, and injector (done after the items above and a clearing of the codes with the misfire code still returning).

You may have a problem with the dual mass flywheel (DMF).

The reason for the DMF in the 993 is to address the engine's ignition-induced rotational speed irregularity cause of vibration in the driveline. At certain speeds ignition timing matches the natural vibrations of the driveline amplifying the vibration causing transmission rattle and body boom.

I am told the litmus test for a failing DMF is to use the PSTII (Porsche tool), put the car in the air and with the car in gear, read the speed sensor directly. I'm told that it will rapidly slow and speed up out of sync with the engine RPM. Also LuK offers a DMF testing tool that physically tests the flywheel once the transmission is removed. If the flywheel needs to be replaced light weight non-dual mass flywheels are widely discussed on this board as a replacement option.

I researched the **non-dual mass light weight flywheel** option and found that if you replace the flywheel with a light weigh single mass flywheel be aware that you should expect a good bit of additional noise, per Luk testing data and Rennlist postings. Some who have done this like the concept and throttle feel of the simpler flywheel and feel it is a good tradeoff for a perception of improved performance. Others have found the noise bothersome. Luk testing has shown installing a single mass flywheel can accelerate wear on engine/drive line components due to increased torsional impact loads to the engine and transmission. Some have experienced idle problems with the light weight flywheel requiring DME software changes to fully address.

Things to consider when Buying / Servicing / Replacing / Upgrading a 993.

My gut tells me that if your car is tracked regularly a single mass flywheel or refreshing the DMF flywheel during a clutch replacement may be worth considering. However for street driven cars that run well but seem to throw a lot of random misfire codes, are not exhibiting a rattling sound when the ignition is switched off and have passed the definitive test above should retain your existing installed OEM DMF at clutch servicing and look for other causes of the misfire related engine light.

- **Alarm light on door** - Flashes in couplets when the car is locked using the remote key fob – This is an indication that the battery is not providing adequate voltage to the system, one of the dome/trunk/engine lid bulbs is out or its switch is bent or broken, the rocker switch on one of the dome light switches is not in the light-out-when-door-open position, a wire is loose or broken or something is wrong with another component in the door lock / alarm / ignition kill system. This symptom should be investigated as it can be something as simple as a battery that needs charging or replacement to a bad component in the door related electronics or a bad alternator/ voltage regulator that results in inadequate battery charging. Although this issue would not cause me to not consider a car for purchase I would be aware of its implications. The quick and simple sequence to diagnose readily repaired items include:

- Verify that car's battery is fully charged @ 12.5 volts or greater when standing after just being charged with the engine off;
- Disconnect and inspect both the ground and the plus connections on the battery ensuring that their clamping points and conductors are clean and good;
- Ensure the frunk, engine lid, dome and glove box lights all work properly – that they illuminate and extinguish when the doors/lids are closed;
- Verify the batteries in your remotes are fresh, the battery contacts are clean and the light on the fob illuminates when you press the button. Many newly purchase fob batteries are actually old and out of date stock. Be sure to check for this to make sure they are truly fresh.

- **HVAC Servo Motors** – The heating/air conditioning system design in the 993, unlike early 911, replaced all the hand levers and cables to control air flow with servomotors attached to air flaps in the duct work. These servo motors are prone to failure and in most cases when one fails the AC seems to not run so cold or the heat doesn't work properly and the OBDC System throws a code pointing you to the offending unit. I have opened a few of these servos up and found that the internal components are not DIY repairable. New or used these are astronomically expensive parts and in the case of used likely exhibit the seeds of failure already. Luckily I stumbled onto a company that you can order a rebuild kit from or simply ship you failed servos to who will rebuild them with new internal parts as needed: www.partisan-autoteile.de.

The left and right heater servos in the foot wells are easily gotten to, the front & center fresh air servo under the cowl in the frunk is not too bad to remove. However the defroster and mixing ones under the cowl seem to be not too easy to get to. If you are already committed to the huge cost of removing the gas tank and the behind the dash HVAC assembly to repair an AC coolant leak I would just go ahead and have the three cowl mounted servos rebuilt at the same time. They all are similar in design, prone to failure, and by doing this you should not incur any additional labor cost to speak of in their replacement.

Things to consider when Buying / Servicing / Replacing / Upgrading a 993.

Minor inspection items:

- **High mounted tail light** - Missing some illumination teeth, a common item. The lamp housing is easily disassembled and if replacement bulbs are purchased from a non-automotive on-line bulb supplier it is inexpensive, <\$10, to replace the entire set. This is table top DIY soldering iron job and is very easy. There seems to be lots of DIY discussions of replacing the bulbs with LEDs. In fact there is a kit that includes the proper LEDs with attached resistors to make the changeover a simple kitchen DIY project. Contact Tore at Bergvillfx.com . Seeing that the bulbs have a 10 year + service life it's a personal decision as to if one wants to do the LED conversion.
- **Airbag light** is on - In many cases this is a non-deployment related **airbag system** error identified by the air bag warning light in the clock extinguishing a short while after the car is started. The error is easily cleared by disconnecting the battery or using Durametric Diagnostic software to reset the light. If this does not work re-soldering the circuit board on the back of the clock solves this issue for some. The soldering is a table top DIY job. See: "[Airbag light fix experience](#)" on rennlist.com 
- **High mounted stop light not working** – This is a common electrical issue related to a failed connection where the wiring passes through the glass. An easy fix with several well documented DIY methods to fix it on the rennlist.com web forum. See: "[High Mounted Cyclops light wire fix](#)" on rennlist.com
- **Horn Honking** - Horn seems to honk for no reason or when one steps on the brakes? That's not a safety feature it's the deterioration of the rubber spacers under the airbag module that keep the horn contacts open. Some purchase a replacement frame inside the steering wheel that comes with new rubber parts installed. My understanding is that the long term fix can be a few dabs of strategically placed silicone bath calk that hardens into rubbery alternate spacers.
- **Turn Signal flashing too fast** -- Have you just replaced a rear side lens housing or replaced the bulbs in one. Turns out that the housings' pigtail plugs for the marker and turn lamp are identical in shape and if switched upon reinstallation you will see this problem. Fix is easy, just switch the pigtail connections back and all is well.
- **Window up/down switch** non-functional - Switch number 964.613.621.00 is slightly different from the older model 911 switches. They have a connector for a dedicated wire plug unlike the older cars that had generic connections on the switch backs. For this reason the replacement switches are dedicated to 964 & 993 and so are expensive at \$50 +/- each.

In most cases the pivot on one side of the rocker paddle has sheared off causing the switch to malfunction.

It turns out you can pry off the switch bezel from the original OE switch body and gain access to the rocker-paddle handle and fix it. Seeing that the original switches can last 15 years or longer vs. the aftermarket switches that seem to last just a few years the below fix should last a long time, a well-documented fix on Rennlist.com. See: "[how to repair broken 964 and 993 window switches](#)" on rennlist.com. If you are not inclined to doing



Things to consider when Buying / Servicing / Replacing / Upgrading a 993.

“MacGyver” fixes the earlier 911, 73’ - 89’ (911.613.621.03) switch shares the same rocker but can be had for a lot less money, if you shop around. So if one wanted to they can buy the earlier switch pop off the bezel and use the new switch’s rocker-paddle to replace the one that is broken in their 993 switch. One could even turn around the contacts in the original switch resulting in the unused contacts now being the active contact points internally. This amounts to a complete refresh of the original switch with an expected 10+ year service life. It is always a good idea to keep an extra functional switch with the junk in you frunk as you never know when you may need a fresh switch to close the window during a rain storm.

- **Replace the car audio speakers** - IF they have not already been replaced. The 993 audio systems in these cars are now over 16 years old. By now speaker cones are dried out, have lost their rigidity and can even exhibit rips. The exact vintage replacement speaker components are readily available however, in my opinion even, a refresh with the least expensive modern aftermarket components are an improvement over the original stock drivers.

For the non-premium system a direct door speaker replacement involves just four screws. For the Premium system as in my car I jettisoned the bass reflex boxes under the door speaker covers and replaced them with 5-1/2” two way aftermarket speakers in conjunction with one inch extension rings. I would not recommend the least expensive aftermarket speaker as they use a simple capacitor as a cross-over and can sound rather harsh. An alternative is to just install a woofer in the door and use it in conjunction with an aftermarket hi-low signal split passive cross-over and the existing OE tweeter up by the window. I covered up the new stuff with the existing padded OEM Premium speaker cover. Looks stock and sounds much better.



For the rear original Premium Sound speakers getting a speaker with a proper fit is a challenge. Instead of replacing the entire premium speaker fixture I chose to just replace the internal cone speaker with an aftermarket 4” coaxial one and disconnected the existing tweeter. Had to drill new speaker mounting holes in the existing rectangular assembly and calk the edges to seal the new speaker frame in once the speaker was screwed to the fixture. Remounted on the rear deck the assembly looked OE stock. Much like the OE speakers this setup really adds only mid-high tones as bass response in the rear deck is very limited.

The wiring diagram in the 993 Shop manual is clear and concise as to how the existing speakers are wired making it easy to tap the new speakers into the existing wiring harness. The upgrade can cost less than \$100 using four inexpensive two-way speakers or the sky is the limit through Best Buy, Crutchfield or other suppliers depending on what level of sound quality you desire.

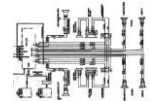

- **Car Seat removal** – A little followed trick to unfastening the seats without the nightmare of a stripped cap screw head is to run the seat position adjustments to their tallest position and leave a drop or two of light sewing machine oil on the screws a day or two before removing the seats. Use a proper size high quality (Snap-On/ Craftsman etc.) metric Allen wrench held squarely to the screws to break the fastener loose. Do not use penetrating oil such as PB Blaster as it will take a very long time to get the oil smell out of your car. Ask me how I know this!

Things to consider when Buying / Servicing / Replacing / Upgrading a 993.

- **To Sub-Woof or not, that is the question** -- Getting good bass response in a 993 audio system can be a challenge. Some have worked up very creative ways to add a subwoofer housing. In all these cases one has to give up some cabin space. The 993 doesn't have much cabin space to begin with so I looked into other options. I ended up replacing the door speaker boxes with a two way speaker system where the woofer is screwed directly to the door's speaker hole and had a stated frequency response of 35 Hz (doubtful). I then replaced the under seat power amp with an aftermarket one and added a Soundstream BX10X Digital Bass enhancing DSP / equalizer for about \$60 new on eBay.

On the plus side the BX10X provides equalization and regenerates the lost lower frequencies and sounds great! For general pop music and things such as acoustic guitar it causes the bass to feel much smoother eliminating the boxed-in like sound inherent in door speakers. I feel for general listening it eliminates the need for a sub-woofer while transforming the sound for the better. On the negative side the intensity control that it comes with needs to be turned down when music with a hard beat is played as it easily overdrives the 75 watt RMS amp causing distortion. Having it in the car a while I have now set my 10 year old Alpine radio's bass control center frequency to 50hz and control the BX10X function using the standard bass control on the radio and found overdrive distortion to not be a big issue. If your goal is to have powerful thumping bass this solution is not for you, most likely a much larger power amp or separately powered subwoofer enclosure would be the ticket. Some newer head units incorporate within them features similar to the BX10X eliminating the need for this extra box.

- **Leg Room** – If your passenger is over six feet tall they may enjoy a little extra front seat leg room. If you slip your finger under the front passenger side seat rail that runs along the center of your car and you feel that the hold down cap screw is installed in the forward most screw mounting hole you're in luck! By unbolting the six bolts holding the seat down one can slide the seat back by about an additional inch and by repositioning threaded screw mounting back plates back an inch so as well they will line up with the new hole positions you can just refasten the seat down and you're done. See "Car seat removal" above to avoid mounting cap screw problems.

- **Hard back sports seat leather** cover edges detached – Two related fixes for this. One is to add additional clips, part number 999.507.526.01, used to pin the edge behind the mounting lip on the hard seat back. The other is to spray Lexol leather conditioner to the back of the leather softening it up and allowing the leather to stretch a little more, reducing the tension that seems to pull the leather edge out of place. If the leather is split on one of the seats there are several ways to have a repair done, anything from replacing the section of leather by an upholstery shop to a DIY solution of gluing a matching leather patch behind the rip.



- **Removing nasty old rear fender guards** – 993 came with clear fender guards to protect the rear wheel arches. These guards develop stress fractures as they age. Putting new ones on is quite easy. Taking the old ones off, not so much due to the film having become brittle and the extremely uncooperative adhesive left behind.; Searching Rennlist under "help removing original stone guards" will bring you to a useful discussion on removing them.
- **Lately having a car "wrapped" is all the rage in the media.** Even Porsche offers this as a factory option on some of its extreme high end vehicles. The PCA member magazine Panorama even did a multi-page spread on this topic that seems to endorse having films applied to your car. With a carefull

Things to consider when Buying / Servicing / Replacing / Upgrading a 993.

reading the article states that the film has a few year service life. In other sections it states how the film is easy to remove. The issue not discussed is what happens if you leave the wrap on beyond its service life? Does the film become brittle? Does the adhesive become uncooperative to remove? Seeing how long it takes to remove old dried out fender guards, is there a horror story in the making when trying to remove out of date film over large areas of your car's body? Who knows? My view is we need to have a few more years of experience using this stuff before I would consider applying it to my car.

- **Making those calipers shine like new** – The black standard calipers on the 993 have a Porsche decal that is clear-coat sealed to the black base paint. With age and temperature cycling the clear-coat detaches from the caliper black paint and looks nasty. An easy cleanup is to chip off the bigger pieces of the clear coat that have come loose and lightly over spray the outward facing side of the caliper with urethane clear-coat purchased at a local DIY store. This can all be done without removing the caliper from the car and can be touched up again at any time in the future. The urethane wicks under the edges of the remaining original clear-coat and provides a like new finish to the caliper face all in one step!



- **Ignition Lock Issues** – Somewhere along the way the ignition lock / steering column deadbolt will encounter mechanical issues such as sticking or electrical issues with the switch. Be aware that in most cases hosing out the lock and mechanism with CRC Electronic Parts Cleaner and re-lubing it with a very little WD40 while in the dash fixes mechanical issues. A new lock cost \$1000 but your car's lock should never ever need replacing as in the worst case it can be taken to a local automotive lock smith who can make it as good as new for a lot less than ordering a replacement from Deutschland. The ignition electrical switch attached to the back of the mechanism is an easily plug it in place part.



Emergency Essentials:

- **Junk in the Frunk** - My 993 has some serious junk in the frunk. Some items are for emergency replacement, some came with the car, some are tools added for ease of field servicing belts or are specific to the car: Also not shown are the OE jack and a bag of accumulated small hardware bits. Below are listed the few important items.



- **DME Relay failure** - 993s like all cars have known failure items that usually show up in the most inopportune moments. For this reason I keep a spare DME relay or sometimes called a fuel injection pump relay part number 993.615.227.00 in my car. This relay has internal solder joints that fail from vibration without notice. If you car's starter turns the engine over but it won't start 99% of the time it is this relay located in the relay box in the frunk of your car. If you have access to a soldering iron this relay is easy to pop open and reheat the solder joints for a quick fix.



- **Belts Shredding** – It is advisable to keep a set of fresh replacement belts as they also fail without notice and you will probably find that an on-the-road garage does not have these specific belts on hand. I also augment my factory tool kit with the few additional tools, three new pulley bolts (900.976.004.01) and



Things to consider when Buying / Servicing / Replacing / Upgrading a 993.

a couple of extra AC compressor mounting nuts (964.126.311.00) to make belt changes easy. In this way if I am stuck out in the middle of nowhere I can replace the belts DIY. A special 12 point splined wrench (999.571.052.02) that fits on the fan center shaft is needed to replace the belts. Many times this tool, supplied with the tool kit, goes missing. Check your kit and make sure you have it or a similar spline socket tool in case you or a technician needs to replace you belts when you are on the road. Recently I have read that some replacement aftermarket alternators use a slightly different from OE style of spline socket on the end of the Alternator shaft. For this reason verify that the tool you have fits onto the end of your vehicles alternator/fan pulley shaft. Use care to make sure you have removed all the belt shrapnel from the failed belt(s) including debris that may have gotten into the fan when replacing the belts. If you ever replace the belts yourself on-the-road use care to reassemble the pulley components, including the shims, in exactly the order they were on originally as to not inadvertently lock the alternator pulley to the fan pulley. When you put it all back together verify that the two pulleys spin independently before tightening the belts down.

In addition to the above one can consider the pulley update listed in Porsche Service bulletin 1378, "In case of alternator belt failure or belt noises in conjunction with pulley"

Parts include:

- Same belt to be used on Carrera (1 ea.) 999 192 343 50 (760 mm long)
- Updated belt to be used on Turbo (1 ea.) 999 192 372 50 (757 mm long)
- Pulley halves (2 ea.) 993 106 268 01 (Cast, Yellow, chromate color)
- Shim (0.5 mm) 964 106 268 31 (as required)
- Shim (0.7 mm) 964 106 268 32 (as required)

You will know if this update has been applied to your vehicle as the upgraded pulley halves are cast metal and gold in color where the original pulley halves are stamped sheet metal. One of the up-sides of this update is that the new arrangement does not allow for the storage of the extra shims on the hub of the installed pulley eliminating a potential cause of confusion during belt changes.

Single Pulley & Unintended Consequences. - With the 911's long history of breaking alternator/fan V belts many 993 owners like the idea of replacing the OE dual belt fan/alternator system with a single belt arrangement using a more robust belt design. The idea sounds great for track cars where reliability at speed trumps all other consequences. For street use the tradeoff seems to be that at idle the alternator spins at a little lower speed which in traffic can be inadequate to maintaining battery charge while supporting the electrical system. With some the aftermarket pulley turning the alternator at lower speed may make the alternator produce whirring sound that some find annoying. I also would have a concern about reducing the long term durability of electrical accessories when powering them at the lower end or below the voltage for which they were designed to run.

- **Key & Fob** – An extra key, fob and fob battery are always good things to have on hand for a number of reasons. Any Porsche dealer can cut you a fresh key stalk from you VIN number. The dealer may require proof of ownership (a title and/or registration) before placing an order for you. The electronic fob/key switchblade can purchased new or used ones can be found on



Things to consider when Buying / Servicing / Replacing / Upgrading a 993.

eBay. Be sure to get one specific to the 993 referencing the same FCC compliance number printed on it as the one you use with your car. For emergencies consider storing the extra key stalk in your wallet and the extra fob and fresh fob battery with the junk in your frunk. Many owners rehouse the fob electronics in a 944 fob housing and use it in conjunction with the really nice classic Porsche flashlight key cap. Both of these can be purchased on-line as well. In fact the housing can be had from eBay in color. My electronic key fob is Yellow; take a guess what color my car is? Mating the key fob to your car so the wireless lock works is quite easy. Here is an easy to follow step by step: "[updated-programming-key-fob-switchblade-key](#)" on rennlist.com

- **Battery Not Charging** - The 993 for some reason lacks a volt meter on the dash. It does include a battery light in the clock that is directly connected to the alternator. When illuminated it indicates that the battery is not charging. My understanding is that the battery light is actually part of the charging system and if the bulb is blown out your alternator will not charge. For this reason it may be advisable to observe that the light illuminates when first turning the ignition on before starting the engine and always check the bulb before digging deeper into an alternator not charging situation. I have never come across this issue however others suggest that if you have the clock out for servicing and run the vehicle you will run your battery down.
- **Battery Status & Charging** -- The 993 likes a fully charged battery with a voltage of 12.5 volts at rest after the engine has been just turned off and can creep down to as low as 12V over an extended sit with the alarm energized. It seems the system draws less current sitting with the alarm on and the door led flashing, go figure? The system voltage should be in excess of 13.5 volts with the engine running. On occasion I have accidentally left the dome lights on in the car over night necessitating the need for a battery charge. I purchased an inexpensive 1.5 amp float charger and cut the end of an old cigarette lighter phone power cord to make an adapter for use in the car. Now on the occasions where a mishap results in a discharged battery I simply plug the charger into the cigarette lighter close the door on the 12 volt wire, lock the car, the dome lights go out, plug the charger into the wall and in and 4 hours the car starts right up. Since the charging rate is very slow one does not have to worry about overheating the battery or any additional venting. The 12 volt charging cord adapter I made can also be made from a plug that comes with the charger and additional parts & wire easily purchased at RadioShack.





Safety Upgrades:

- **Illuminated Rear Center Reflector** - The 993 sold in some ROW countries included rear facing fog lights. These are not present on the USA cars. As a result the center section on USA cars have unused lamp positions under the red lens. These two positions can be filled with two bulbs wired to the marker and stop light wires on the left or right tail light. By illuminating these two additional positions the 993 benefits from greatly increased visibility at night from the rear and outstanding stop indication. Here is a fun DIY project to add this simple lighting upgrade on rennlist.com: "[how to illuminate the unused us center reflector positions](#)".



Things to consider when Buying / Servicing / Replacing / Upgrading a 993.

- **High Intensity Discharge Headlights (HID)**, as you are probably aware the headlamp units pop right out of the 993 using the release levers on each side in the frunk. You may not be aware that when doing a low beam HID conversion on the Carrera most any aftermarket HID lamp kit that includes the “slim” ballast will fit completely inside the headlight unit and is fully reversible. Here are some useful notes if you plan to do this very satisfying DIY project on rennlist.com: “ [Installing High Intensity Discharge \(HID\) headlights on 993 the gotchas](#) ”. In this posting it is mentioned the reaming out of the existing halogen lamp socket. It turns out this is not necessary in most cases. It only becomes an issue if the replacement xenon bulb has a slightly oversized glass envelope, most don’t. Getting headlight pod back in and the electrical plug lined up can be a bit of a trick. Spray some Teflon lube on the tracks the pods slide in on and rub some of the lube around the edges of the electrical socket. Having done this, the thing should slid right in and fully seat no problemo!
- Recently aftermarket **LED headlamp** bulbs have become available. White LEDs emit a group of line emission spectra at specific points along the visible band blending to approximate white light. For this reason the color spectrum seen under the illumination of “white” LEDs is different than that of an incandescent bulb. Specifically, there is a marked attenuation of output in a region around 480 nm (blue/green). Halogen (incandescent) & High Intensity Discharge bulbs emit a broad spectrum of light much like the sun. The unique properties of White LEDs may result in differences in perception while driving under their illumination.
- **Automatic door locking** -- Since the 993 already has electric door locks and a readily accessible door locking switch on the center console this is an easy DIY upgrade. Several people on the internet sell 12 volt adjustable time delay relay switch kits in the <\$20 range. I purchased one of these solder-it-yourself kits and at the kitchen table put it together in about half an hour. It requires only 4 wires two to the console door lock rocker switch, one to the ignition switch and one to ground. The timer is adjustable. I set mine so once the ignition is powered 10 seconds later the door lock switch is pulsed. I packaged the board in a drugstore travel soap box and tied it up under the dash. Has now been working for years and we don’t even think about locking the doors anymore. The down side is you will have to disable it when programming key fobs and if you start the car while not sitting in it and quickly close the door you can lock yourself out with the engine running. Ask me how I know this. Both of these issues can be mitigated by making the delay to lock time shorter where it times-out and fails to lock the door because the door is still open and for programming fobs, the addition of an in-line disabling toggle switch to the hot wire from the ignition switch. I added notes as to this issue in my owner’s book so some time in the future some future owner does not go berserk trying to program key fobs or worse yet goes out and purchases an unneeded and expensive replacement controller.
- **Wheel Nuts** – If your 993 still has the factory anti-theft wheel nuts installed now is the time to get rid of them. The OE anti-theft nuts are prone to failure potentially leaving you stranded at the side of the road with a flat tire. New standard nuts are readily available from any Porsche distributor. Removing a broken anti-theft nut involves the use of a hole saw with the potential to damage a wheel in the process.

Things to consider when Buying / Servicing / Replacing / Upgrading a 993.

- **Adding an emergency engine release cable** – I have read stories about the very rare occurrence when the engine lid release cable fails. This is a problem as releasing the latch to replace the cable can be difficult. Fortunately adding an emergency release cable is easy. I used a length of solid core steel galvanized picture hanging wire for this purpose.
 - From inside the engine compartment I drilled a small hole behind the driver side corner light housing and;
 - Fished the wire through the hole and out the space above the light fixture between the bumper cover and the steel body panel.
 - I threaded the other end of the wire through the extra hole in the latch release lever and threaded a nut on the end of the wire as a stop. In this way when using the regular latch release cable the added cable simply slides through its latch release lever hole and doesn't bind.
 - Coiled up an extra length of picture hanging wire behind the corner lamp and reinstalled the fixture.

Now if the latch won't actuate because the primary cable is broken I can simply unscrew the lamp fixture and pull on the backup release wire.

- **Door Panel Wrap** -- The 993 has a wedge shaped clipped on insert on the door cards. This insert can be easily removed and wrapped in any number of fabrics, vinyl or leather. This is a kitchen table DIY project that one only needs



to know how to use a scissors and a staple gun to do.

- **Shift Boot Cover** -- Lots of Rennlisters speak of replacing their shift boot. This seems to be an expensive disassembly job. An outstanding upgrade is to just cut a somewhat triangle shaped piece of leather or vinyl to form a cone shaped cover for the existing boot. Making a trial pattern out of craft paper works quite well for defining the shape of the leather. I used 3M yellow weather adhesive to hold the seams together and I made a hoop out of coat hanger wire wrapped into a glued hem at the bottom edge of the cone. This allowed the boot cover to snap right into the existing shifter well right over the OE boot. Looks great, is completely reversible and requires no disassembly!



- **Gauge Trim Rings** -- I purchased these and went the extra step of buying a can of spray paint to color match them to the body color of the car. You can buy exact color match paint in a spray can on-line or you can use a color available at your local home improvement store. I tacked each of them on with three small dollops of GE silicone bath calk. In doing this less is more and it has lasted for years without trouble.



- **Making Modern 12 Volt Accessories fit in the old oversize cigarette lighter** – The simple way is to wrap a rubber band around the neck of the plug before inserting it. However if one is looking for a nice OE quality look and fit without modifying the dash or socket just buy an all metal dash socket in the new smaller size at your local auto parts store or on eBay.



Things to consider when Buying / Servicing / Replacing / Upgrading a 993.

Discard the outer socket housing and cut the inner housing in half across its diameter. With a little bending and tin snips / file work adjust the cut end of the barrel of the outward facing half to create a metal slide in liner that fits inside and stays in place in the existing in-dash socket housing.

Here is a posting on the subject: [cigarette lighter modification](#)

- **Adding Cup holders** – Where are you going to put that HOT cup of coffee? One of the first upgrades I added to my 993 was a cup holder. I purchased it from an interior guy in the UK. It is something that can be easily homemade if desired. Buy the plain between the seats console cup part# 964.552.159.00 then cut a cardboard cover for it in the shape of cup holes. Ideally I would use a piece of art store 4 ply rag mount board for this (cotton fiber base). Wrap the cardboard cover in vinyl or leather using 3M molding / weather strip adhesive, (black or yellow). Glue the finished piece to the top of the console cup. Then remove the cassette or CD holder in your car and mount the cup in its place. If you already have a cup it can be un-mounted via the screw under the pad in its base and then it can be used to make this addition. Clearly this is a Kitchen table kind 'a project.



- **Adding Heated Seats** – It is shockingly easy to add the heated seat option to the 993 hard back seats, search Rennlist for "[Heated Seats Shockingly Easy to add to Hard Back Seats](#)" to learn how to do it.



- **Cleaning up the look of the engine bay** – The engine bay insulating blanket above the engine can look rather shabby over time. If you replace it with the OE service part its edge will develop cracks



in as little as 20K miles. If the blanket in your car is not falling apart a good fix is to trim up the visible edge using a dry-wall edge cuff from your local DIY store. Simply cut a suitable length and fit it in place. If you want to get fancy you can fit it with the longer edge face up and use the buttons that hold the edge of the blanket in place to firmly tie it down.

In my case I just force-fitted it with the shorter edge face up and it seems to stay in place just fine. Once trimmed to size it can be painted flat black as I did or really any color including body matching color. Takes about five min. to fabricate with a total cost is just \$8 or so including paint and it looks quite nice.



- **Replacing seat upholstery** - I replaced the leather seat upholstery on my hard back sport seats in my car. This is an advanced DIYer project well suited to workers who can work slowly and methodically. To review my experience with this see "[replacement leather seat upholstery](#)" in the Rennlist web site 993 discussion forum and my comments near the end of the discussion thread.
- **LED Marker/Turn/Stop lights** - When upgrading incandescent marker/turn/stop lamps on a 993 to Light Emitting Diode (LED) based lights be aware that you will be adding complexity:

LEDs draw substantially less current than a bulb and unlike bulbs current passing through a diode only goes in one direction, called the forward direction. Current trying to flow the reverse direction

Things to consider when Buying / Servicing / Replacing / Upgrading a 993.

is blocked. If the voltage across a diode is negative, no current can flow, and the diode looks like an open circuit.

- Reported issues that have workarounds posted on Rennlist related to LED upgrades include:
 - The high mounted LEDs stop light illuminating very faintly with ignition-on while not pressing the brake, this could be called a feature not a bug by some;
 - When tail brake lights are converted over to LED's, the cruise control ceases to function. It seems that if a ballast resistor is added to the stop light circuit, adding back a resistive load, it seems to resolve this issue. The fix can be purchased from <https://www.bergvillfx.com/> or a suitable high wattage resistor with an ohm value equal to the load provided by two stop light filaments can be purchased on eBay to get the job done.

If you are an adventurous soul and are willing to sort out the issues that may arise when replacing resistive load bulbs with diode based illumination, have at it. Over a very short time, I believe, the LED solutions will become more robust, not having symptoms requiring workarounds.

Body fluids, Andy's opinion:

- **Oil** - I have always used Mobil 1. Although it is called synthetic technically it is not, it is made from petroleum but it has been extensively processed to remove the bulk of the naturally occurring substances, paraffin wax, etc. that must be kept in solution by the additives to avoid sludge. I use one of the multi-grades' with the higher ZDDP levels, > = 1000 PPM as I have come to understand this additive reduces scuffing of components in the valve train. I do not use the racing or motorcycle oils that have very high levels as this, I understand, may shorten the life of the catalytic converters.



What sold me on this oil was when I first used it on my 86' Carrera. In Cleveland winters it would take twenty minutes or more for non-synthetic labeled multi-grade oil to warm up enough for the oil pressure to drop into its proper pressure range. When I filled the engine with Mobil 1 it took less than 60 seconds from dead cold as in well below 32F. Most engine wear, I understand, happens at startup when an engine is not yet warm, the oil is thick and so does not properly lubricate. With Mobil 1 this period is very short. As a plus Mobil 1 is stocked at Walmart, works for me. Then again has anyone, who does not track their car, ever seen a "catastrophic oil related engine failure" as fear mongered in oil advertisements? If one changes their oil regularly with the OE recommended brands and viscosities, probably not. If you believe this fear mongering dribble you may have watched Dr. Strangelove one too many times and agree with General Jack "Wacko" Ripper about bodily fluids and their adulteration as a Communist plot.



Things to consider when Buying / Servicing / Replacing / Upgrading a 993.

- **Fuel System Cleaner** - I am standing on thin ice as I have only anecdotal support of my opinion concerning this subject. I hear of issues with clogged fuel injectors and the need to remove and service or replace them from time to time on Rennlist. I have had two electronically fuel injected Carreras. The first one I drove 150K miles without a fuel related problem. My current 993 has never exhibited an injector problem. I attribute this to treating the engines twice a year with two consecutive tanks of gas where I added Chevron's Techron fuel system cleaner. My understanding is that Techron unlike competitive products will not produce burnt by-product solids as competitive products can if used in high concentration. Also Techron is part of the standard additive package used in Shell branded gasoline. As a side note adding this stuff to a hard to start Weed Wacker does the trick every time!



Other notes:

- **Clutch and transmission servicing** can be done on a 993 without removing the engine in many cases the labor cost for a full engine out can be avoided.
- **On Board Diagnostic connections** - I have found that as a best practice if one experiences a fault code related to an electronic sensor such as an oxygen sensor, wheel rotation sensor or an electronic device such as the Idle Control Valve it is best to clean the electrical plug and socket to the device before assuming it is a failed component as a dirty connector is simply a fact of life on a +/-20 Year old car. Also if your OBD Reader is acting strangely it is not a bad idea to clean the diagnostic port on your car and the plug supplied with your reader.
- **OBD Code Ignition Faults** - On a 993 if the ignition wires are bad or the rotor or cap are bad or the plugs are fouled the light will likely be on with a misfire OBD Code present.
- **Getting meaningful OBD Code information from your reader** - On our cars many of the fault codes are the result of indirect information received from the oxygen and other sensors that is analyzed by the Motronic Electronic Control Unit. For this reason the proper operation of the sensors is paramount in allowing your reader to give you good information. For example if you have ignition or emission codes that relate to data the oxygen sensors provided it is advisable to replace any suspect oxygen sensors and rerun the codes before coming to any conclusions as to the root cause of the Diagnostic Code.
- I use Durametric and have found that at times it provides erroneous information. Things such as listing fault codes that do not exist in the Porsche OBD catalog of codes or even codes that seem to not clear properly when reset. In my case I purchased a 2nd hand held Autel AL519 reader just for reading ignition module codes that I use from time to time to validate what I am seeing from the Durametric software. As a plus the Autel reader also provides individual readiness code status info not available in Durametric.
- **Kinematic Adjustment** - There is lots of talk of the need for the rear kinematic adjustment unique to the 993 during an alignment. It turns out that one of the reasons that this and the other settings need to be looked at during a routine alignment has to do with the adjustments slipping out of position primarily if you

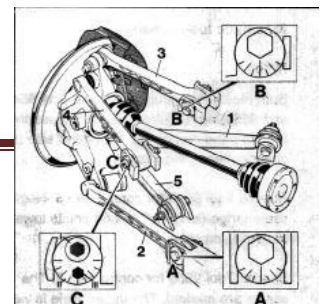

Things to consider when Buying / Servicing / Replacing / Upgrading a 993.

track your vehicle. With this in mind I would take a cell phone picture up-close of the rear suspension setting positions at the time of a known good alignment and periodically check the settings through visual inspection. The settings for the rear suspension are labeled A, B & C in the above illustration from the shop manual. It may also be a good idea to take a Sharpie pen and mark a vertical line down each of the coil-overs on your car. In this way if a spring purchase or a sway bar mount slips you can see it.

I read all sorts of discussions of the need for the factory tool for setting the rear kinematic toe control on the 993 during an alignment. The factory tool is a very neat piece of unobtainium. There is an aftermarket tool that unlike the factory tool requires the unbolting things to use it. In reality the factory tool is nothing more than a proprietary tilt gauge similar to the gauge you see on a sailboat that lets you know how much the boat is heeling over while under way. For this reason I see no reason why a precision digital tilt gauge, purchased on eBay for \$25, could not be used for the same purpose. One would simply need to calibrate the gauge to the factory gauge by placing it against the kinematic rear toe arm after a known good setting with the factory tool and then record the value. I am sure there is a little more complexity and subtlety to developing this idea into a working how-to. At this point I'll leave it to others' volition to sort this out.

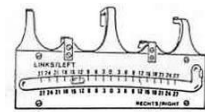

- **Turn signals & dead batteries:** The 993 being of European origin has a street parking "safety" feature where if the turn signal is active the marker lamp for that side of the car remains illuminated when the ignition key is removed. North American owners' usually first encounter this feature when they go to start their 993 in the morning and the battery is dead, "It's not a bug, it's a feature!"
- **Battery Bummers:** I read almost daily about cars with dead batteries. On the 993 the alternator, if running correctly, should produce enough current to run all the electrical accessories and still charge the battery. It may be helpful to get one of those eBay cigarette lighter plug voltmeters. It should read 12.5 volts with the engine just turned off and from 13.5 to 14.2 volts or so with the engine running. Overnight a good battery typically drifts down to 12.3 Volts +/- with the car parked, the turn signals off and the doors locked with the little light on the door flashing in single, not couplets, flashes every second or so. Also be sure to unplug the volt meter from the lighter socket when you park your car as it too will contribute to the run-down rate of your battery.
- All conventional car batteries sacrifice moisture from their cells as a product of the electrolysis process in the battery or simply evaporation. Even conventional so-called maintenance free batteries have cells that need servicing and some can be pried opened and checked, others do not allow this but I am told can be MacGyvered and filled although it seems like a bit of an invasive process on YouTube. If you can check the fluid level in your battery occasionally and make sure it is full up to the fill indicators in each cell. Use distilled water to top it off if needed. For future reference it may be advisable to look for a brand of battery that allows for topping off the cells next time your battery needs replacing.
- **The Cabin Pollen Filter** - The 993 has two replaceable air filters that are located on the left and right side of the car below the windshield in the frunk. Their design suggests they have a long service life. Installing new filters can be very frustrating if you are unaware of the secret that the plastic alignment pin on each filter needs to be pointed towards



Things to consider when Buying / Servicing / Replacing / Upgrading a 993.

12:00 o'clock not 3:00 or 9:00 o'clock as some try to do during reassembly. Knowing this will turn a one hour job involving mutilation of the filter with a mat knife into a five to ten minute job! Once I figured this out I made a note of it with a "this way up" arrow on the replacement filter with a Sharpie pen so years from now I don't have to relearn this secret.

- **Underbody Covers** - The 993 was carefully designed to have a smooth underbody. This includes three underbody covers.

- The front under body cover is rarely removed and is solidly screwed in place.
- The transmission cover is regularly removed during servicing. In addition to its role in aerodynamics it protects the transmission from dirt and road debris. Many of these covers have gone missing during inattentive service work and they are expensive to replace. I had this problem so now my cover has my name and a "please reinstall this" note in bright orange spray paint emblazoned on it. 
- The third cover is a tray under the engine, in my opinion, it just serves to cause the engine to retain heat (bad), hide maintenance issues such as an oil leak and make jobs such as changing the oil a lot more work.

In the Fall the cover does help to avoid having your car set a pile of leaves under it on fire and a very very embarrassing visit to you street by the local Fire Department involving all you neighbors standing and watching from their lawns as one profusely apologizes to the fire chief while explaining he usually gets these calls where a teenager is turfing someone's lawn and sets it on fire and how surprised he is to find an older guy as a factor in its causation. Don't ask me how I know this. I just leave this cover off and going forward avoid backing over piles of raked leaves.

Inspecting a car for purchase:

If you are using this list as guidance on a prospective car purchase here are my additional thoughts:

I do not put a lot of faith in Pre-Purchase Inspections (PPI) by third parties as they will generally only capture gross mechanical issues and miss most wear related parts and body condition items. Unfortunately every few months I read the rants of a Rennlist member who has purchased a car where the inspection was done by a Porsche dealer or independent dealer who has the vehicle for sale or the dealer or shop that has been servicing the vehicle for the seller. Invariably undisclosed or simply missed issues arise poisoning the relationship with the new owner and potentially sully a service provider's reputation unfairly and unnecessarily. The solution to this issue is to not have the inspected done by the selling dealer or in the case of a private sale by the seller's servicing entity.

Inspections by any dealer or local servicing shop should be reviewed very carefully as items you would consider expensive service work they may consider routine maintenance or minor nuisance items and not worth mentioning.

Things to consider when Buying / Servicing / Replacing / Upgrading a 993.

Most new car Porsche dealers are no longer familiar with these older cars and therefore do not provide any enhanced inspection simply because they are a Porsche dealer. Recently Porsche has developed the Porsche Classic Partner program where certain Porsche USA dealers are certified to service older cars like the 993. These dealers may be better suited to conduct an inspection or simply use an independent shop that specializes in servicing the older air cooled cars.



- **Mail-order Brides** - Buying online from an on-line or eBay based independent dealer requires special handling. The best solution for any remote buy is to negotiate the price contingent on an inspection and then fly down and look at the car. Let's face it, buying a twenty year old car without personally inspecting it and driving it around a little is a train wreck in the making.

For any purchase, if at all possible, look at the car yourself with the help of a friendly local PCA member as a ride-with who knows how the car should drive and feel. Making a request through the 993 Technical Forum on Rennlist.com will usually turn up a PCA member in the geography where the car is located who will be more than glad to assist you.

- **CarFax** is only as valuable as the facts they have in their system. Once out of warranty, something that happened a long time ago with these cars, they are generally serviced and repaired by their owners DIY



or small independent mechanical or boutique body shops. These sources of repair almost universally do not report on their work to anyone CarFax uses as an information source. Beyond having a salvage title in its history these reports, I feel, are of little value.

- **Salvage titles** can be in the history of a car for a number of reasons unrelated to damage or flood recovery. For example a stolen car claim from an owner where the car was towed from the spot the owner illegally parked it while bar hopping and then makes a stolen loss claim with their insurance company. Six months later the tow lot owner, wanting their back storage fees, gets in touch with the now former owner who refers them to the insurance company who now has a car to sell on salvage title. It is surprising how often stuff like this happens especially way back in the 90's. So having a salvage title in a car's history can represent an outstanding value or a nightmare in the making. In such cases try to ascertain why the salvage title was issued before considering one of these cars.
- **Leak Down Testing** - Cylinder leaks can be from a poorly seated spark plug, worn rings or a valve that does not seat properly. I hear lots of discussion about leak-down testing of engines as a validation of engine condition. From reading the comments I have come to believe that the conditions under which such tests are done, are in many cases, inadequately controlled, Results can vary widely making such tests unreliable as an absolute test of condition. They may be of some very very limited antidotal value in capturing variances between individual cylinders on an engine in the presence of other gross operating symptoms.



Here is a recent comment in reply to my Rennlist posting questioning a potential valve leak, a common reason a top end rebuild is proposed:

Things to consider when Buying / Servicing / Replacing / Upgrading a 993.

My posting question:

“Thinking that there may be carbon debris in the valve seat, can one take a valve cover off and rotate the valve by its stem to possibly knock it free? Maybe put some choke cleaner or Techron in the cylinder to help with this.”

Rennlisters reply:

“I've had mixed results when doing leak-downs on older motors. Sometimes I gotta tap the valve to get it to snap shut. During hand rotation the valve will hang open on carbon. During running operation it will snap shut [work properly] due to speed of the valve closing. I would not cry just yet. Warm the motor up well and pull the suspected valve cover and see if you can pull the rocker off and tap the valve stem slightly when doing the leak down. Don't run it up to 100 PSI. Start a bit lower when tapping the valve. You should hear the leak stop.”

Another shop that was conducting a Pre-Purchase Inspection (PPI) for a Rennlist member suggested



that a “top-end” rebuild was needed. In investigation multiple cylinder leak-down percentages in the 75% range were found, however the dyno test of the same engine put output at 237hp at the wheels, allowing for drive train losses of 10% from the factory stated 270hp this number is quite good for a 16+ year old car that in this case runs perfectly otherwise. If the leak-down results were to be relied upon the car should barely run, exhibit the check engine light, not be able to hold idle and should be blowing more blue smoke than Jerry Garcia did in his lifetime. Go figure? What appears as general low engine output, OBDC issues a rough idle or a tapping like sound at the exhaust can have many reasons that should be ruled out before considering cracking open the engine!

- **Body & Paint Work** - Seeing the age of these cars paint & body work is present on most examples. For example I am on my third rear bumper cover as cars have scraped and bumped my car while parked in the local shopping center. Cosmetic damage to parts that bolt onto the car are not a big deal as they can be replaced and restored to original condition, things such as hoods, doors, front ¼ panels, front & rear bumper covers.
- **Why Paint Matters** – Having your car painted is a big deal as properly applied paint will last the life of your vehicle. Here is my rundown on the subject based on both working with paint shops and having personally painted both new and used bumper covers using commercial methods and materials:
 - One stage paint uses a primer and one or more top coats that carry the color. Two stage paints involve a primer, color layer(s) and a clear-coat top coat that provides the gloss. Contrary to Porsche's own marketing literature, solid color 993 are in many cases painted in single stage paint, my 96' Speed Yellow car is. If your car is painted with single stage paint any repainting should be done the same way. This will require finding a restoration quality shop that is willing to do this as most shops will just use a two stage paint on what is now just part of your car.

Shops like to use two stage paint as all newer cars are painted this way, it is simpler to apply and when their paint system can't produce a color match between panels they can feather the color layer of the paint when applying it to merge the dissimilar color of body panels. Once

Things to consider when Buying / Servicing / Replacing / Upgrading a 993.

feathered they can overspray the job with clear coat. With single stage paint where the color and final finish layer are one and the same getting a good color match up front is how it is done requiring skill and the flexibility in selecting a paint system that can produce a good color match.

- Most higher volume modern shops will only use their in-house paint systems as it keeps their cost down and meets EPA requirements. Usually these shops use acrylic paint or in some cases water solvent based paints. These paints and this form of application are significantly inferior to the paint that came on your car and can fail in just a few years. Smaller restoration paint shops do not maintain in-house paint systems. Due to their lower volume of work they are not required to meet the same EPA rules so they can select from multiple paint system suppliers paint that will color match very closely and not exhibit adhesion issues as it ages and gasses out.
- All acrylic paints, the most commonly used, are somewhat brittle. This can cause things such as clear coat peeling around edges, failing from UV exposure or paint cracking or flaking off a bumper cover with minor flexing. The most durable and flexible paint is a two part urethane sometimes called 2K, used with a catalyst. Once it hardens it is much less susceptible to damage from chemicals, weather, or UV rays. **It retains its flexibility/adhesion and if applied with a proper compatible primer will outlast the car. It is available as both one and two stage paint.**
- **Painting a new vs used bumper cover** - Bumper covers flex. For this reason using a 2K urethane paint is especially important. Also achieving good adhesion is a big deal. An odd experience I have had is that achieving good adhesion on a new replacement cover is actually more difficult than over spraying an undamaged used bumper cover. I believe this has to do with some of the plastic's chemical components migrating to the surface of the part and creating a coating that is difficult for the paint to grasp to.

Some new covers are also pre-primed, however the primer in many cases is not compatible with the paint system being used so it must be sandpaper prepped and the part re-primed. I have used adhesion enhancing sprays to assist in overcoming these issues. Even with these sprays getting the primer coat down right and achieving good even adhesion can be a challenge.

With used bumper covers where the existing paint has good adhesion resolves many of these issues as the plastic is encapsulated under the paint and therefore does not cause issues. In this case the existing finish needs to be sanded to prep it for good mechanical adhesion and the proper primer applied to ready it for painting.

Beware of reconditioned bumper covers. Many have had cracks or rips repaired in them. This is typically done by using melt gun plastic to fuse and fill the crack. I have tried these products and found that although they can produce flawless repairs from a visual standpoint the repair is not as strong as the surrounding material. For this reason using a reconditioned cover where the rip or crack extends to the edge of the part can result in a propagation point for a future failure. The take away from this is that one should only consider a used cover if you can personally inspect it.

Things to consider when Buying / Servicing / Replacing / Upgrading a 993.

- **A quick mirror paint gouge fix:** I inadvertently put a deep 1/8" wide gouge line in the mirror housing of my single stage painted Speed Yellow 993. So deep in fact that it exposed the white plastic housing underneath. To eliminate the gouge I took some leftover paint from the last time the car was painted and put a little in a metal cup letting it dry out into thick pancake syrup like consistency. I used a small artist's paint brush and painted several coats of the paint over the gouge until it filled above the surface of the surrounding surface. I let it dry thoroughly between coats and then used 1500 grit wet sandpaper and a water hose to sand the paint flush with the housing's surface. Worked great. Didn't take very long. Used care not to sand through the finish of the surrounding paint. Looks great, it may be worth a try before committing to the expense of having a body shop overspray the entire mirror. The nice thing is the process can be repeated over and over until a satisfactory result is achieved.
- **Impact damage** to a door jamb or in the rear quarter panel areas can profoundly diminish the integrity of the car and so should be carefully investigated. Also any serious front end or rear damage where the unibody was involved signals that you should not be considering the car. Such damage is identifiable by a competent body shop guy.



In conclusion I generally have a strong visceral response whenever a Service Advisor or Technician uses the phrases "engine drop" or "while I'm in there" and it causes me to ask lots of questions about necessity. In reality there are really just a very few mandatory "IF" items that may need attention on a 993 as it gets older, a testament to the high quality engineering and build on these cars.

If the car starts easily and runs reliably do not consider any actions that involves internal engine repairs. An occasional single cylinder OBDC misfire code after a long drive on a hot day or a slow oxygen sensor code in the cooler months require no action, just clear the code and see if it comes back. 993s tend to have a little uneven rumble at idle – this is normal. A slight cycling of the RPM on cold days, a small stumble on acceleration when the engine is cold or in very hot weather, an engine that uses some oil between oil changes, this is normal stuff.

A puff of smoke after sitting a while is OK.

You know the line, "accept the things I should not fix, have courage to fix the things I must and have the wisdom to know the difference"

Andy