

WM 399055 CHANGING OIL FOR FINAL DRIVE (WITH TRANSMISSION OIL) (EXCEPT CARRERA GTS, CARRERA "EDITION", CARRERA CABRIOLET "EDITION", CARRERA 4 "EDITION", CARRERA 4 CABRIOLET "EDITION") > TOOLS

Designation	Type	Number	Description
manual metering pumps, Porsche set	Workshop equipment	WE 1372	
socket wrench set, 39-piece	Workshop equipment	WE 1640	

WM 399055 CHANGING OIL FOR FINAL DRIVE (WITH TRANSMISSION OIL) (EXCEPT CARRERA GTS, CARRERA "EDITION", CARRERA CABRIOLET "EDITION", CARRERA 4 "EDITION", CARRERA 4 CABRIOLET "EDITION") > TECHNICAL VALUE

Location	Description	Type	Basic value	Tolerance 1	Tolerance 2
Screw plug or filler plug on Porsche Doppelkupplung (PDK)	M18 x 1.5 - replace sealing ring	Tightening torque	27 Nm (20 ftlb.)		
Drain plug and filler plug on manual transmission	M18 x 1.5	Tightening torque	35 Nm (26 ftlb.)		
Drain plug for differential space	M10 x 1	Tightening torque	10 Nm (7.5 ftlb.)		

WM 399055 CHANGING OIL FOR FINAL DRIVE (WITH TRANSMISSION OIL) (EXCEPT CARRERA GTS, CARRERA "EDITION", CARRERA CABRIOLET "EDITION", CARRERA 4 "EDITION", CARRERA 4 CABRIOLET "EDITION") > INFORMATION

Fig 1: Identifying Oil Filler Screws And Drain Plugs

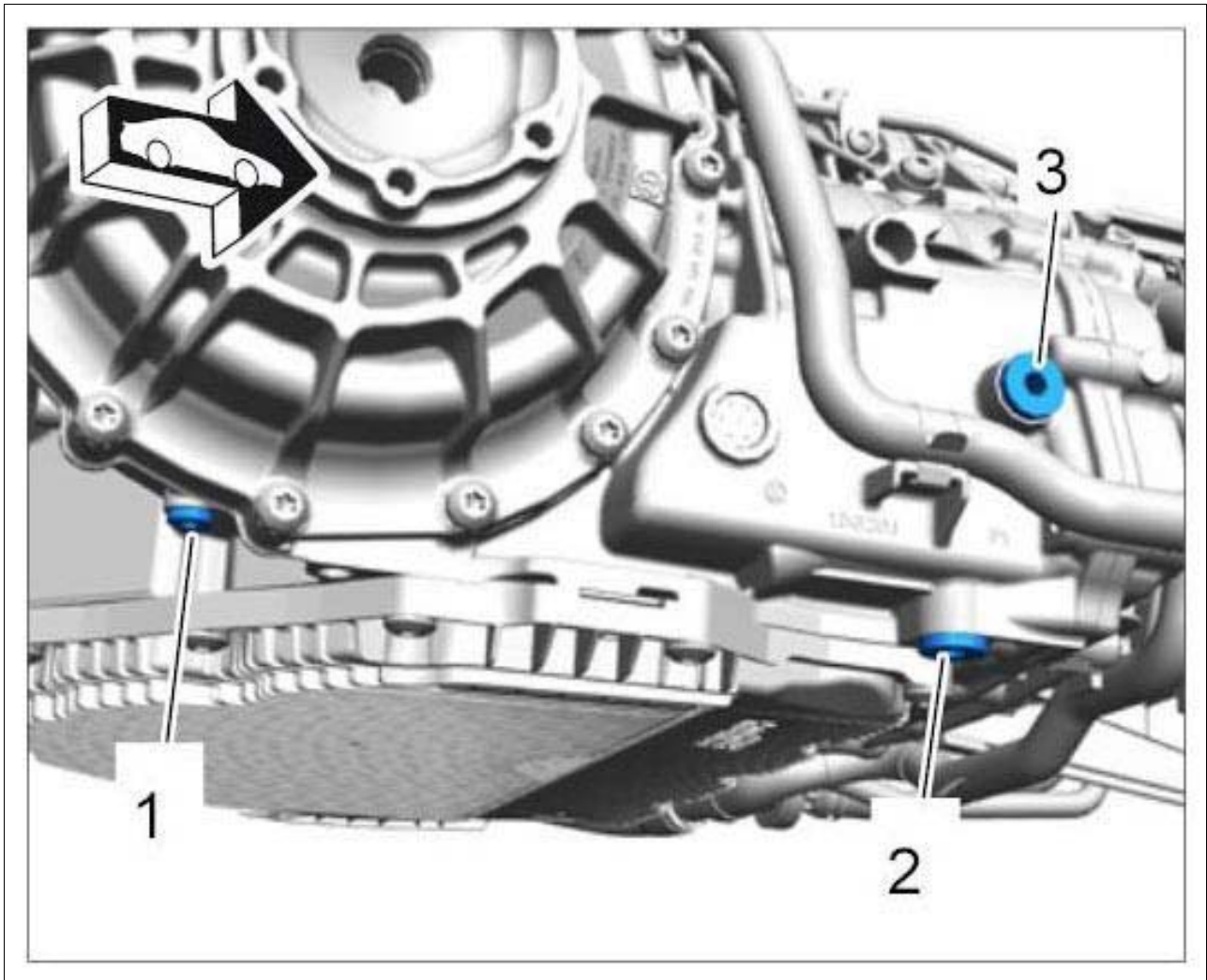

Courtesy of PORSCHE CARS NORTH AMERICA, INC.

1. Oil drain plug for differential space
2. Oil drain plug for gearwheel set space
3. Oil filler screw/inspection plug

WM 399055 CHANGING OIL FOR FINAL DRIVE (WITH TRANSMISSION OIL) (EXCEPT CARRERA GTS, CARRERA "EDITION", CARRERA CABRIOLET "EDITION", CARRERA 4 "EDITION", CARRERA 4 CABRIOLET "EDITION") > PRELIMINARY WORK

Information

- Align the lifting platform so that the vehicle is raised according to driving position.
 - To do this, the contact points of the lifting platform must be guided without gaps onto the jacking points of the vehicle before lifting the vehicle.
1. Jack and raise the vehicle at the prescribed jacking points.

→ 4X00IN LIFTING THE VEHICLE .

2. Remove cover for rear underbody.

→ 519419 REMOVING AND INSTALLING COVER FOR REAR UNDERBODY .

3. Place oil collection pan under the transmission.

WM 399055 CHANGING OIL FOR FINAL DRIVE (WITH TRANSMISSION OIL) (EXCEPT CARRERA GTS, CARRERA "EDITION", CARRERA CABRIOLET "EDITION", CARRERA 4 "EDITION", CARRERA 4 CABRIOLET "EDITION") > DRAINING OIL FOR FINAL DRIVE (WITH TRANSMISSION OIL)

1. Unscrew oil filler screw -1- using socket-wrench insert (a/f 8 mm) from **socket wrench set, 39-piece WE 1640** .

Fig 1: Removing Oil Filler Screw/Inspection Plug

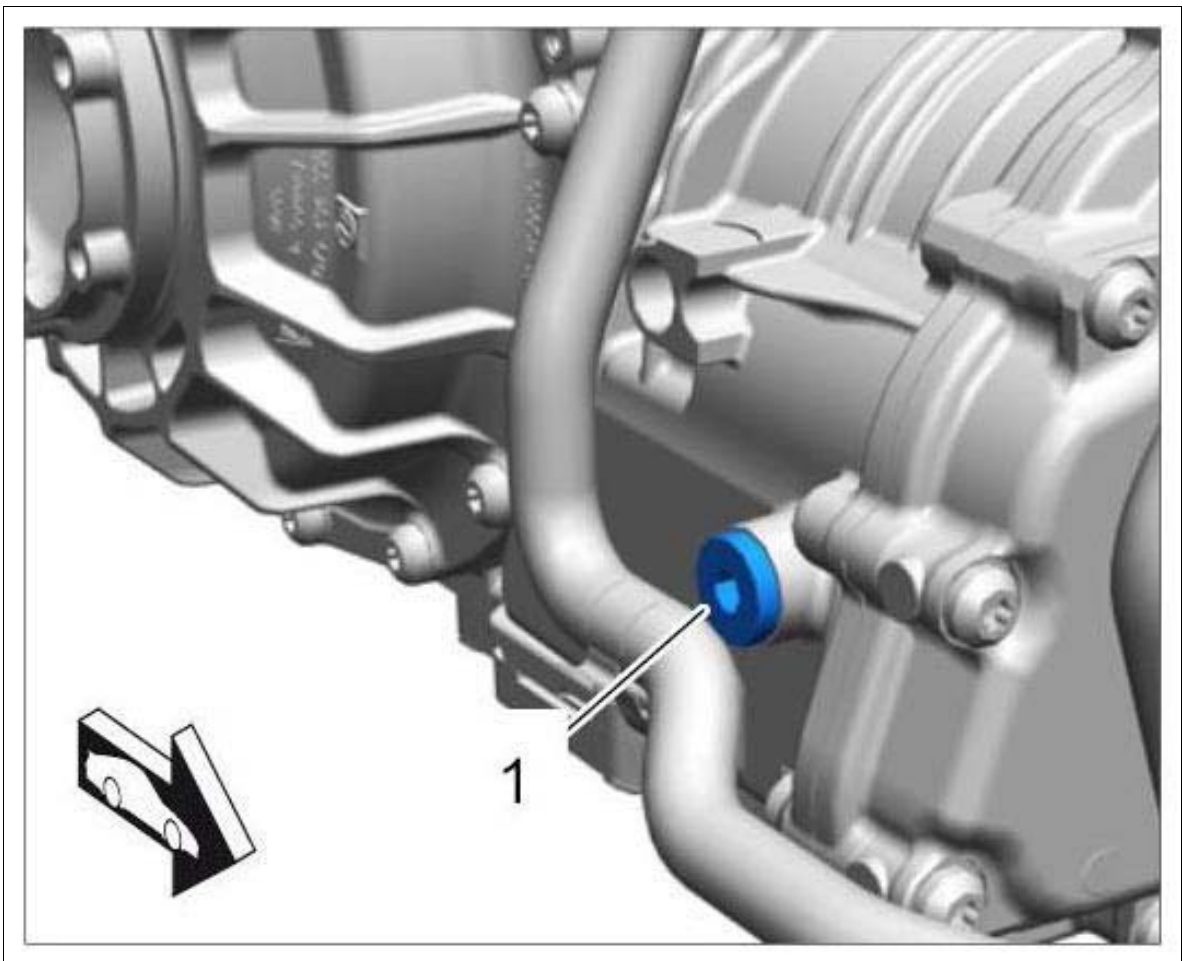

Courtesy of PORSCHE CARS NORTH AMERICA, INC.

 **WARNING:** Hot fluid

1. Danger of scalding

- Let the fluid cool down.
- Wear personal protective gear.

2. Drain oil for final drive.

1. 2.1. Unscrew oil drain plug for differential space -1- and drain oil for final drive.

Screw in and tighten new oil drain plug.

Tightening torque 10 Nm (7.5 ftlb.)

Fig 2: Removing Oil Drain Plug For Differential Space

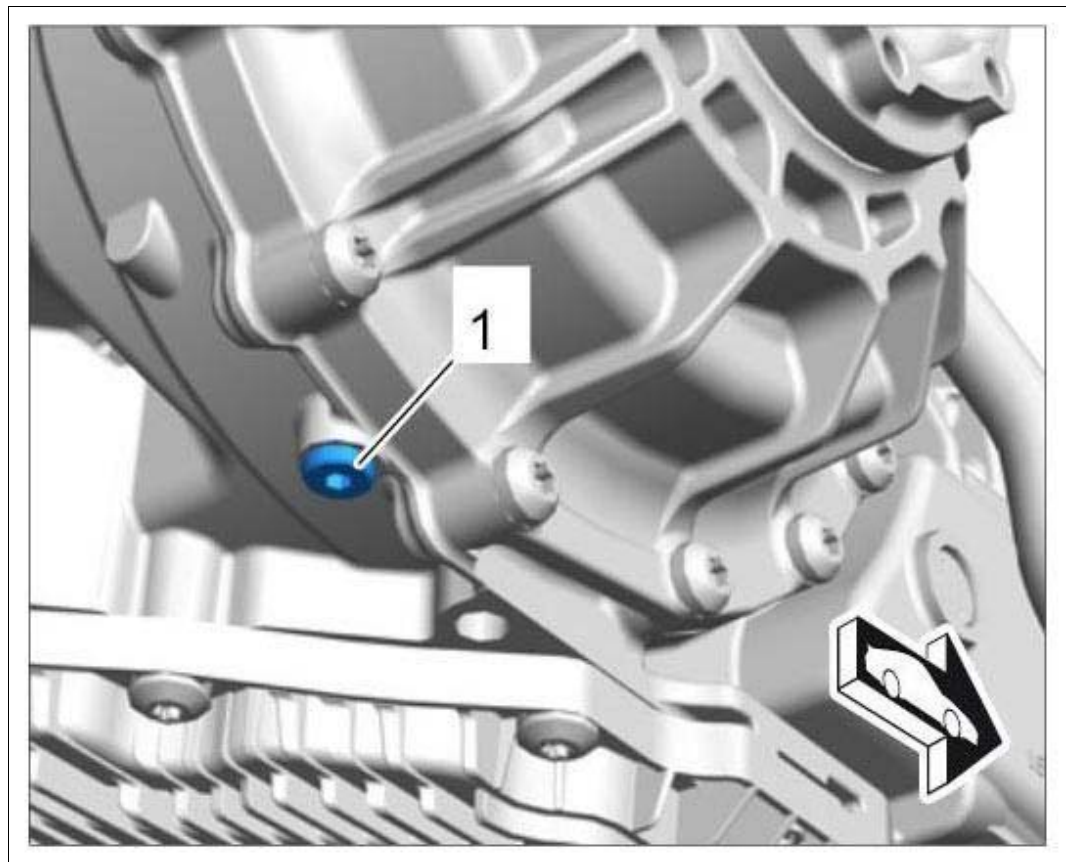

Courtesy of PORSCHE CARS NORTH AMERICA, INC.

2. 2.2. Unscrew oil drain plug for gearwheel set space -2- and drain oil for final drive.

Screw in and tighten new oil drain plug.

Porsche Doppelkupplung (PDK): **Tightening torque 27 Nm (20 ftlb.)**

Manual transmission: **Tightening torque 35 Nm (26 ftlb.)**

Fig 3: Removing Oil Drain Plug For Gearwheel

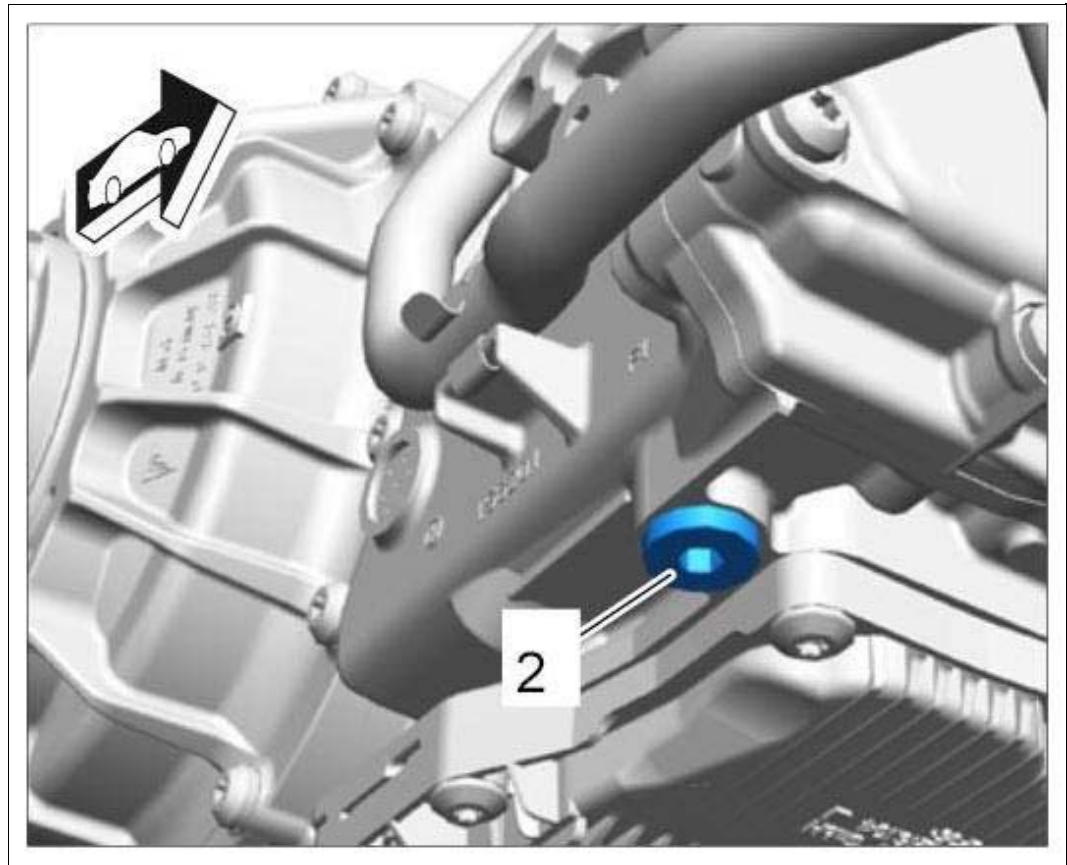

Courtesy of PORSCHE CARS NORTH AMERICA, INC.

WM 399055 CHANGING OIL FOR FINAL DRIVE (WITH TRANSMISSION OIL) (EXCEPT CARRERA GTS, CARRERA "EDITION", CARRERA CABRIOLET "EDITION", CARRERA 4 "EDITION", CARRERA 4 CABRIOLET "EDITION") > ADDING OIL FOR FINAL DRIVE (WITH TRANSMISSION OIL)

1. Top up oil for final drive.

1. 1.1. Add oil for final drive using **manual metering pumps, Porsche set WE 1372** until oil emerges at the filler opening.

2. Screw in filler screw by hand.

The transmission must be prepared in order to fill oil correctly and the oil level must be checked!

→ 399035 CHECKING AND TOPPING UP OIL FOR FINAL DRIVE (WITH TRANSMISSION OIL) .

Observe specification for GT3 vehicles!

Fig 1: Removing Oil Filler Screw/Inspection Plug

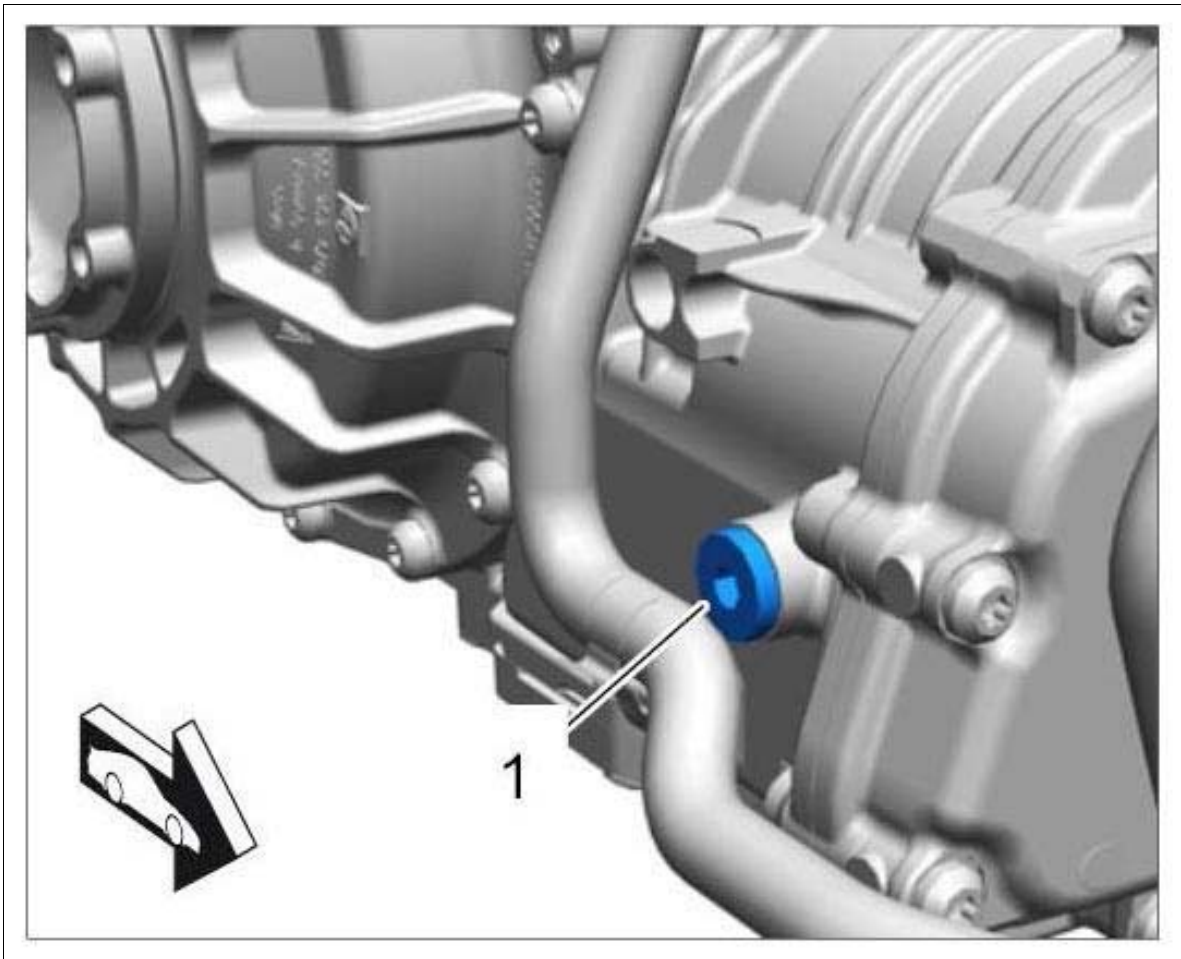

Courtesy of PORSCHE CARS NORTH AMERICA, INC.

WM 399055 CHANGING OIL FOR FINAL DRIVE (WITH TRANSMISSION OIL) (EXCEPT CARRERA GTS, CARRERA "EDITION", CARRERA CABRIOLET "EDITION", CARRERA 4 "EDITION", CARRERA 4 CABRIOLET "EDITION") > SUBSEQUENT WORK

1. Install cover for rear underbody.
→ 519419 REMOVING AND INSTALLING COVER FOR REAR UNDERBODY .
2. Lower the vehicle.

WM 399055 CHANGING OIL FOR FRONT FINAL DRIVE (GT3 RS) > TOOLS

Designation	Type	Number	Description
-------------	------	--------	-------------

open-end/ring Commercially Nr.98-1
wrench insert available tool Pos.1



WM 399055 CHANGING OIL FOR FRONT FINAL DRIVE (GT3 RS) > TECHNICAL VALUES

Location	Description	Type	Basic value	Tolerance 1	Tolerance 2
Drain plug and filler screw for transmission oil for front final drive	M18 x 1.5 - replace sealing ring	Tightening torque	32 Nm (24 ftlb.)	+/-4 Nm (+/- 3 ftlb.)	
Drain plug and filler screw for transmission oil for front final drive	M18 x 1.5 - replace sealing ring	Tightening torque	32 Nm (24 ftlb.)	+/-4 Nm (+/- 3 ftlb.)	

WM 399055 CHANGING OIL FOR FRONT FINAL DRIVE (GT3 RS) > PRELIMINARY WORK

Information

Only use oil approved by Porsche .

1. Jack and raise the vehicle at the prescribed jacking points.
→ 4X00IN LIFTING THE VEHICLE .
2. Remove cover for front underbody.
→ 519219 REMOVING AND INSTALLING COVER FOR FRONT UNDERBODY .
3. Place oil collection pan under the transmission.

WM 399055 CHANGING OIL FOR FRONT FINAL DRIVE (GT3 RS) > DRAINING OIL FOR FRONT FINAL DRIVE > DRAINING OIL FOR FRONT DIFFERENTIAL

 **WARNING: Hot fluid**

- *Danger of scalding*

→ Let the fluid cool down.

→ Wear personal protective gear.

1. Unscrew filler screw -2- .
2. Unscrew drain plug -1- and collect differential oil.

Fig 1: Identifying Drain Plug And Filler Screw For Differential Oil

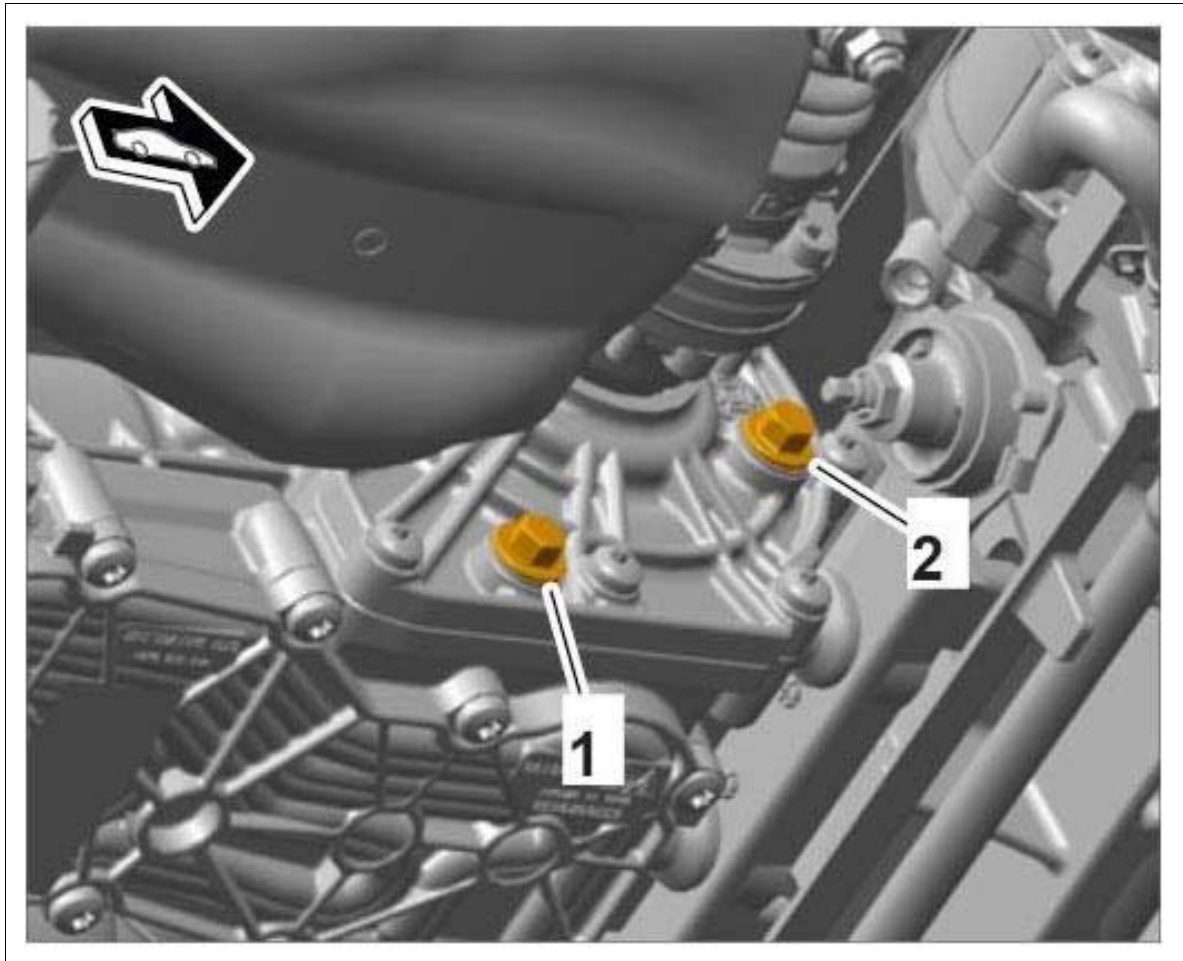

Courtesy of PORSCHE CARS NORTH AMERICA, INC.

3. Clean the drain plug and filler screw and replace sealing rings.

WM 399055 CHANGING OIL FOR FRONT FINAL DRIVE (GT3 RS) > DRAINING OIL FOR FRONT FINAL DRIVE > DRAINING OIL FOR ELECTROMAGNETIC CLUTCH

⊗ *WARNING: Hot fluid*

- *Danger of scalding*

→ Let the fluid cool down.

→ Wear personal protective gear.

1. Unscrew filler screw -2- .
2. Unscrew drain plug -1- and collect clutch fluid.

Fig 1: Removing Drain Plug And Filler Screw For Clutch Fluid

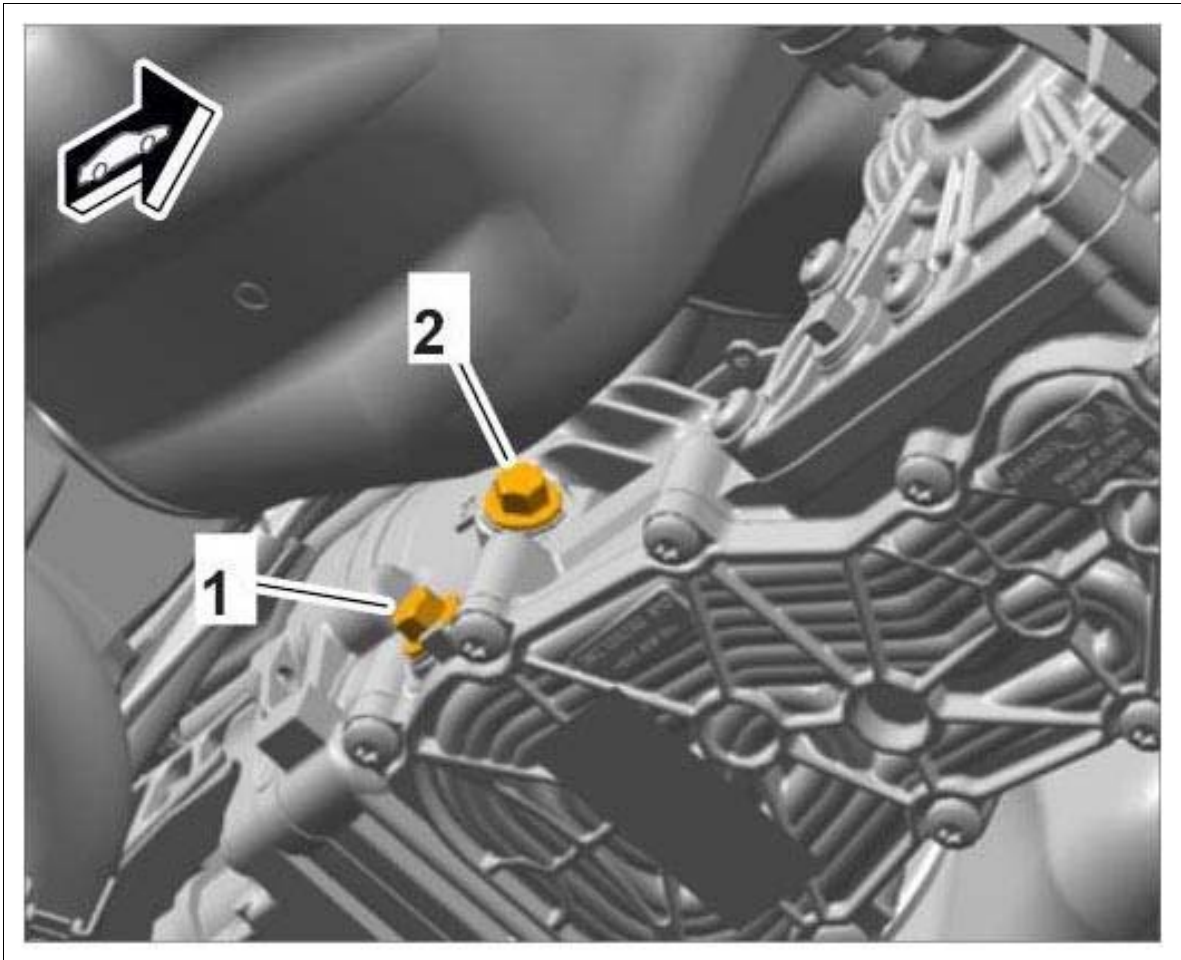

Courtesy of PORSCHE CARS NORTH AMERICA, INC.

3. Clean the drain plug and filler screw and replace sealing rings.

WM 399055 CHANGING OIL FOR FRONT FINAL DRIVE (GT3 RS) > FILLING IN OIL FOR FRONT FINAL DRIVE > FILLING IN OIL FOR FRONT DIFFERENTIAL

Information

Only use **differential oil** approved by Porsche .

1. Screw in drain plug with a new sealing ring and tighten it.

Tightening torque 32 Nm (24 ftlb.) +/-4 Nm (+/-3 ftlb.)

2. Fill in differential oil up to the lower edge of the filler opening.

→ **Filling capacity: 0.8 Liter**

3. Screw in filler screw with a new sealing ring and tighten it.

Same tightening torque as for drain plug!

4. Remove residual traces of oil from the transmission.

WM 399055 CHANGING OIL FOR FRONT FINAL DRIVE (GT3 RS) > FILLING IN OIL FOR FRONT FINAL DRIVE > FILLING IN OIL FOR ELECTROMAGNETIC CLUTCH

Information

Only use **clutch fluid** approved by Porsche .

1. Screw in drain plug with a new sealing ring and tighten it.

Tightening torque 32 Nm (24 ftlb.) +/-4 Nm (+/-3 ftlb.)

2. Fill in clutch fluid up to the lower edge of the filler opening.

→ **Filling capacity: 0.8 Liter**

3. Screw in filler screw with a new sealing ring and tighten it.

Tool recommendation: 3/8-inch torque wrench with open-end/ring wrench insert Nr.98-1 Pos.1

Same tightening torque as for drain plug!

4. Remove residual traces of oil from the transmission.

WM 399055 CHANGING OIL FOR FRONT FINAL DRIVE (GT3 RS) > SUBSEQUENT WORK

1. Install cover for front underbody.

→ 519219 REMOVING AND INSTALLING COVER FOR FRONT UNDERBODY .

2. Lower the vehicle.

WM 399519 REMOVING AND INSTALLING CONTROL UNIT FOR ALL-WHEEL DRIVE (PTM) (CARRERA 4, TURBO, CARRERA 4S, CARRERA 4 GTS, TARGA 4, TARGA 4S, TARGA 4 GTS, CARR. 4 CABRIO, CARR. 4S CABRIO, CARR. 4 GTS CABRIO, GT3 RS) > TOOLS

Designation	Type	Number	Description
PIWIS Tester II	Special tool	9818	