

WM 399035 CHECKING AND TOPPING UP OIL FOR FINAL DRIVE (WITH TRANSMISSION OIL) (EXCEPT CARRERA "EDITION", CARRERA CABRIOLET "EDITION", CARRERA 4 "EDITION", CARRERA 4 CABRIOLET "EDITION") > TOOLS

Designation	Type	Number	Description
manual metering pump, Porsche set	Workshop equipment	WE 1372	
socket wrench set, 39-piece	Workshop equipment	WE 1640	

WM 399035 CHECKING AND TOPPING UP OIL FOR FINAL DRIVE (WITH TRANSMISSION OIL) (EXCEPT CARRERA "EDITION", CARRERA CABRIOLET "EDITION", CARRERA 4 "EDITION", CARRERA 4 CABRIOLET "EDITION") > TECHNICAL VALUES

Location	Description	Type	Basic value	Tolerance 1	Tolerance 2
Screw plug or filler plug on Porsche Doppelkupplung (PDK)	M18 x 1.5 - replace sealing ring	Tightening torque	27 Nm (20 ftlb.)		
Drain plug and filler plug on manual transmission	M18 x 1.5	Tightening torque	35 Nm (26 ftlb.)		

WM 399035 CHECKING AND TOPPING UP OIL FOR FINAL DRIVE (WITH TRANSMISSION OIL) (EXCEPT CARRERA "EDITION", CARRERA CABRIOLET "EDITION", CARRERA 4 "EDITION", CARRERA 4 CABRIOLET "EDITION") > INFORMATION

Fig 1: Identifying Oil Filler Screws And Drain Plugs

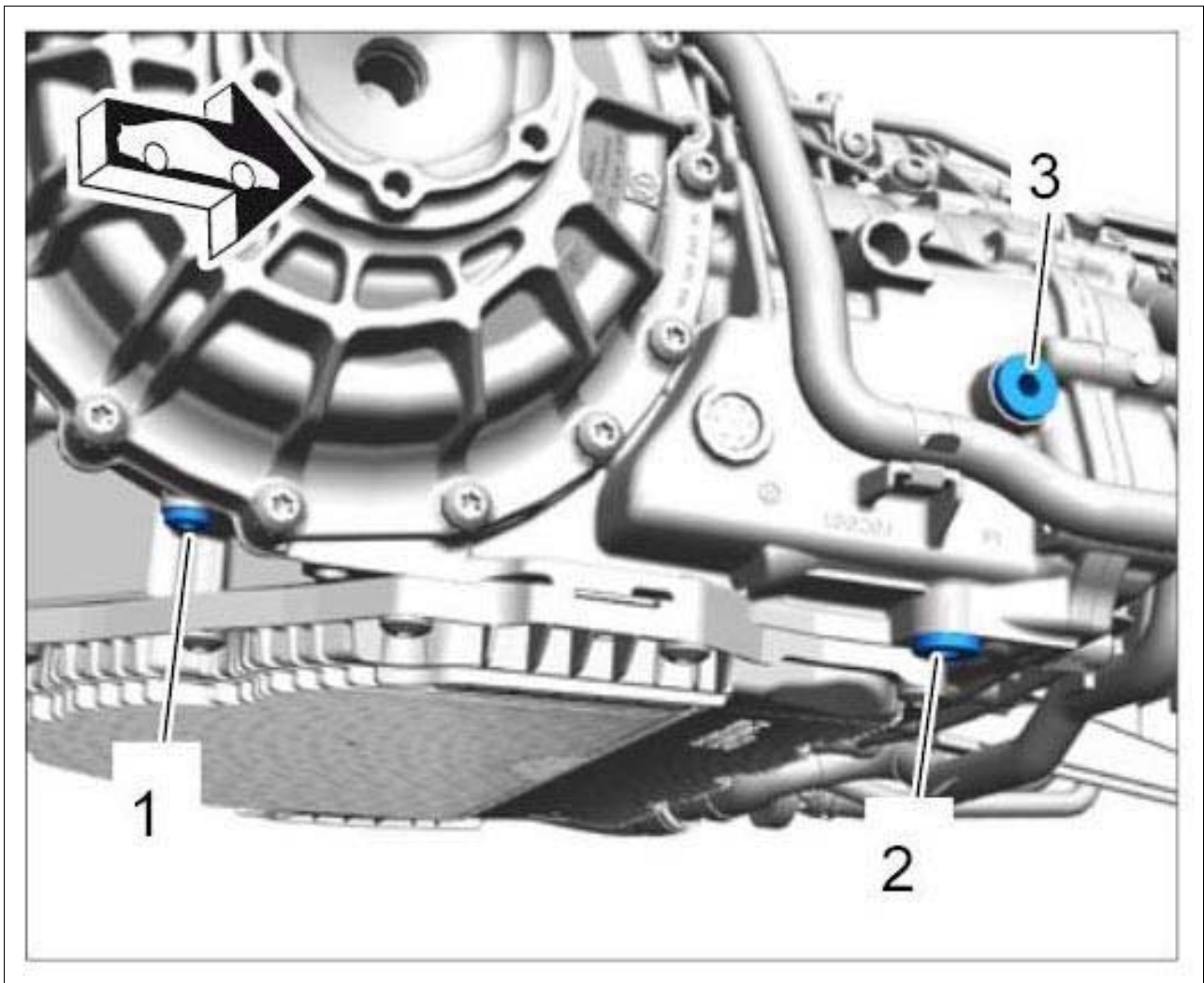

Courtesy of PORSCHE CARS NORTH AMERICA, INC.

1. Oil drain plug for differential space
2. Oil drain plug for gearwheel set space
3. Oil filler screw/inspection plug

WM 399035 CHECKING AND TOPPING UP OIL FOR FINAL DRIVE (WITH TRANSMISSION OIL) (EXCEPT CARRERA "EDITION", CARRERA CABRIOLET "EDITION", CARRERA 4 "EDITION", CARRERA 4 CABRIOLET "EDITION") > PRELIMINARY WORK

Information

- Align the lifting platform so that the vehicle is raised according to driving position.
 - To do this, the contact points of the lifting platform must be guided without gaps onto the jacking points of the vehicle before lifting the vehicle.
1. Jack and raise the vehicle at the prescribed jacking points.

→ 4X00IN LIFTING THE VEHICLE

2. Remove cover for rear underbody.

→ 519419 REMOVING AND INSTALLING COVER FOR REAR UNDERBODY .

3. Place oil collection pan under the transmission.

WM 399035 CHECKING AND TOPPING UP OIL FOR FINAL DRIVE (WITH TRANSMISSION OIL) (EXCEPT CARRERA "EDITION", CARRERA CABRIOLET "EDITION", CARRERA 4 "EDITION", CARRERA 4 CABRIOLET "EDITION") > CHECKING AND TOPPING UP OIL FOR FINAL DRIVE (WITH TRANSMISSION OIL)

 **WARNING: Hot fluid**

- *Danger of scalding*

→ Let the fluid cool down.

→ Wear personal protective gear.

1. Unscrew filler screw **-1-** using socket-wrench insert (a/f 8 mm) from **socket wrench set, 39-piece WE 1640** .

1. 1.1. Add transmission oil using special tool **manual metering pump, Porsche set WE 1372** until oil emerges at the filler opening.

2. Screw in filler screw by hand.

Information

Basic requirements for filling the transmission correctly:

1. Vehicle is horizontal on the lifting platform
2. Transmission oil temperature is approx. 20 °C
3. Engine off, transmission is not turning.

3. **Get the vehicle ready:**

1. Raise the vehicle until the wheels can turn freely.
2. Start engine
3. Engage 1st gear using the manual shift gate
4. Allow the transmission to turn at idle speed for **two minutes** .
5. Move selector lever to "N"
6. Switch off engine
7. **Wait for ten minutes!**

Information

The transmission temperature must not be higher than 40 °C when filling the transmission.

4. Unscrew filler screw -1- .

1. 4.1. **Transmission oil runs out:** Oil level in transmission is OK (for GT3 vehicles, see Step 4.3).
2. 4.2. **Transmission oil does not run out:** Add oil using **manual metering pump, Porsche set WE 1372** until oil emerges at the filler opening.
3. 4.3. **150 ml of transmission oil must be extracted if the oil level is at the lower edge of the filler opening on GT3 vehicles!**

5. Screw in and tighten new oil filler screw -1- .

1. 5.1. Porsche Doppelkupplung (PDK): **Tightening torque 27 Nm (20 ftlb.)**
2. 5.2. Manual transmission: **Tightening torque 35 Nm (26 ftlb.)**

Fig 1: Removing Oil Filler Screw/Inspection Plug

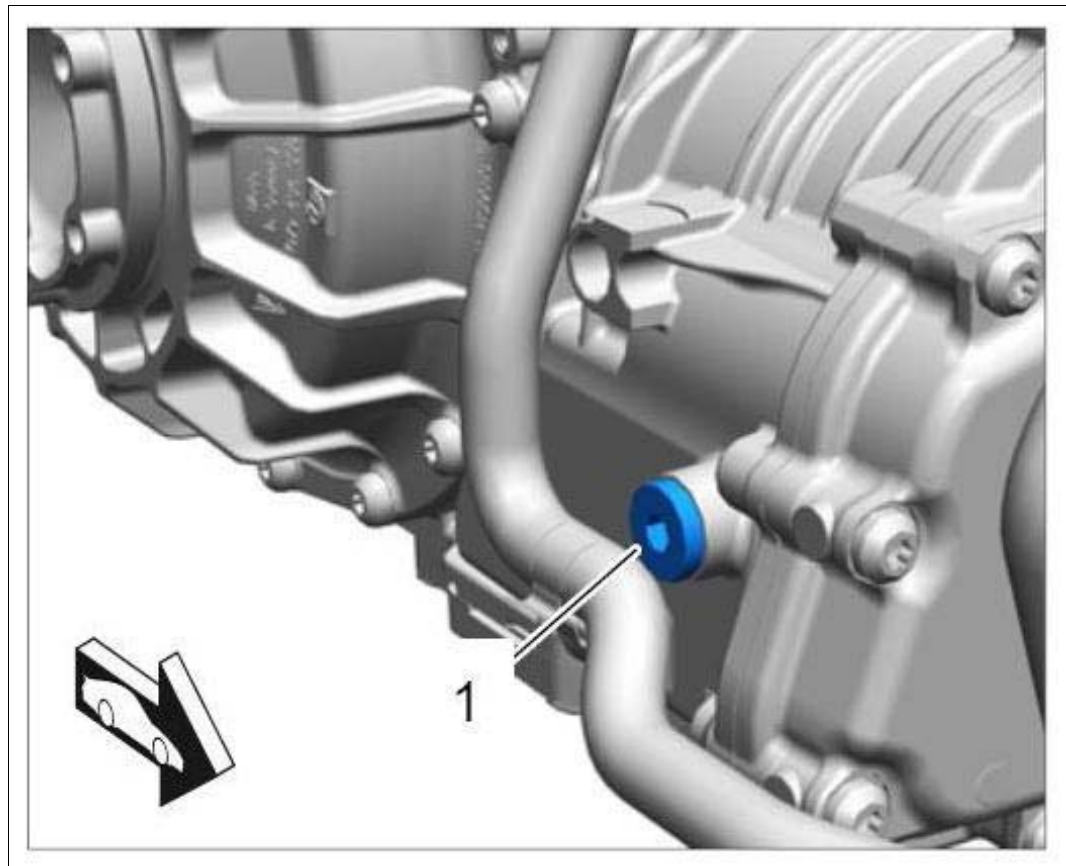

Courtesy of PORSCHE CARS NORTH AMERICA, INC.

WM 399035 CHECKING AND TOPPING UP OIL FOR FINAL DRIVE (WITH TRANSMISSION OIL) (EXCEPT CARRERA "EDITION", CARRERA CABRIOLET "EDITION", CARRERA 4 "EDITION", CARRERA 4 CABRIOLET "EDITION") > SUBSEQUENT WORK

1. Install cover for underbody.

→ 519419 REMOVING AND INSTALLING COVER FOR REAR UNDERBODY .

2. Lower the vehicle.

WM 399035 CHECKING AND TOPPING UP OIL FOR FRONT FINAL DRIVE (GT3 RS) > PRELIMINARY WORK

Information

Only use oil approved by Porsche .

1. Jack and raise the vehicle at the prescribed jacking points.

→ 4X00IN LIFTING THE VEHICLE .

2. Remove cover for front underbody.

→ 519219 REMOVING AND INSTALLING COVER FOR FRONT UNDERBODY .

3. Place oil collection pan under the transmission.

WM 399035 CHECKING AND TOPPING UP OIL FOR FRONT FINAL DRIVE (GT3 RS) > CHECKING AND TOPPING UP OIL FOR FRONT FINAL DRIVE > CHECKING AND TOPPING UP OIL FOR FINAL DRIVE

Information

Only use **differential oil** approved by Porsche .



WARNING: Hot fluid

- *Danger of scalding*

→ Let the fluid cool down.

→ Wear personal protective gear.

1. Unscrew filler screw -1- .

Fig 1: Removing Differential Oil Filler Screw

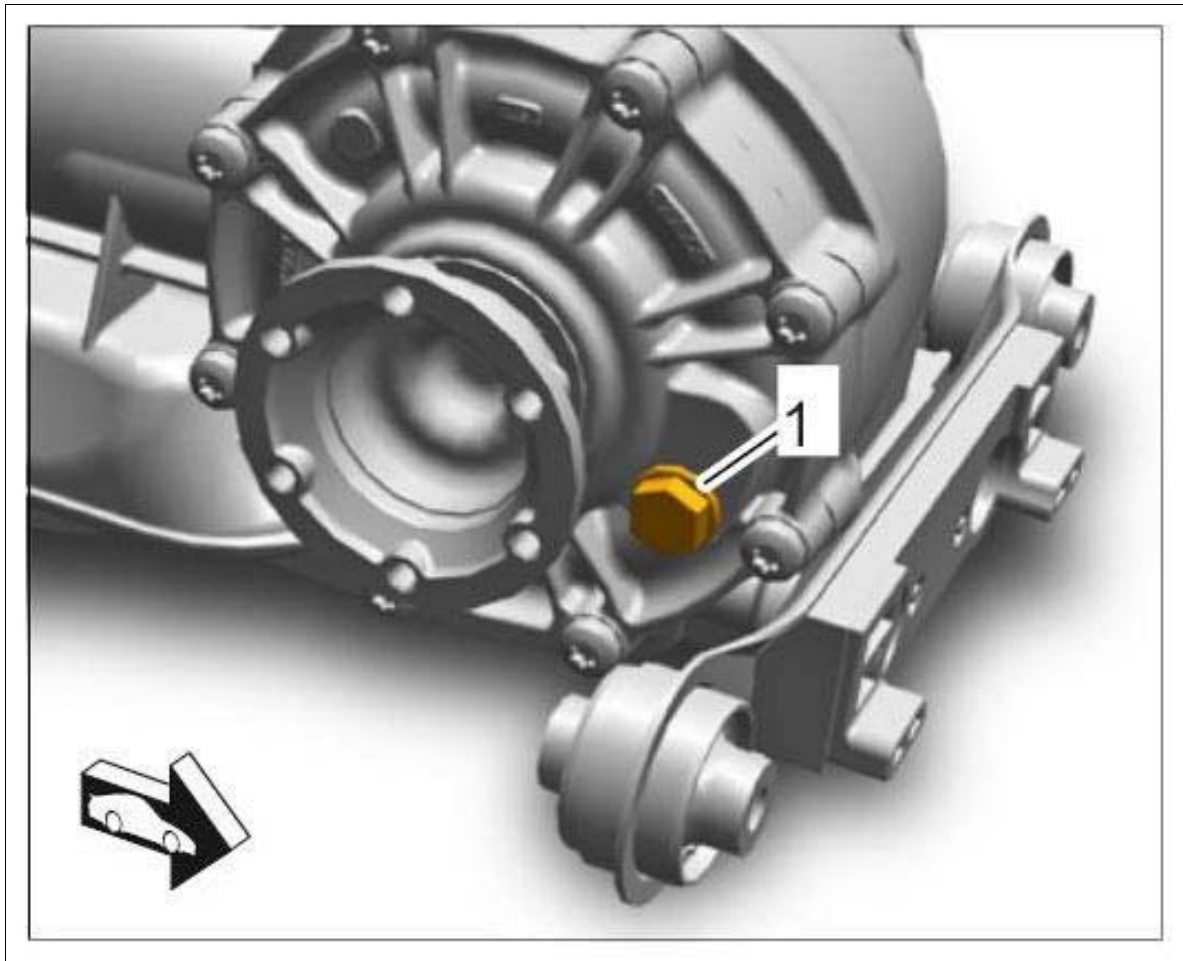

Courtesy of PORSCHE CARS NORTH AMERICA, INC.

2. Check oil level.

1. 2.1. The oil level is OK if differential oil emerges. Continue with Step 4.

2. 2.2. If no differential oil emerges, the oil level in the final drive is too low. Continue with Step 3 .

3. Fill in differential oil up to the lower edge of the filler opening.

4. Clean oil filler screw and screw it in.

WM 399035 CHECKING AND TOPPING UP OIL FOR FRONT FINAL DRIVE (GT3 RS) > CHECKING AND TOPPING UP OIL FOR FRONT FINAL DRIVE > CHECKING AND TOPPING UP OIL FOR ELECTROMAGNETIC CLUTCH

Information

Only use **clutch fluid** approved by Porsche .

 **WARNING: Hot fluid**

- *Danger of scalding*

→ Let the fluid cool down.

→ Wear personal protective gear.

1. Unscrew filler screw -1- .

Fig 1: Removing Clutch Fluid Filler Screw And Drain Plug

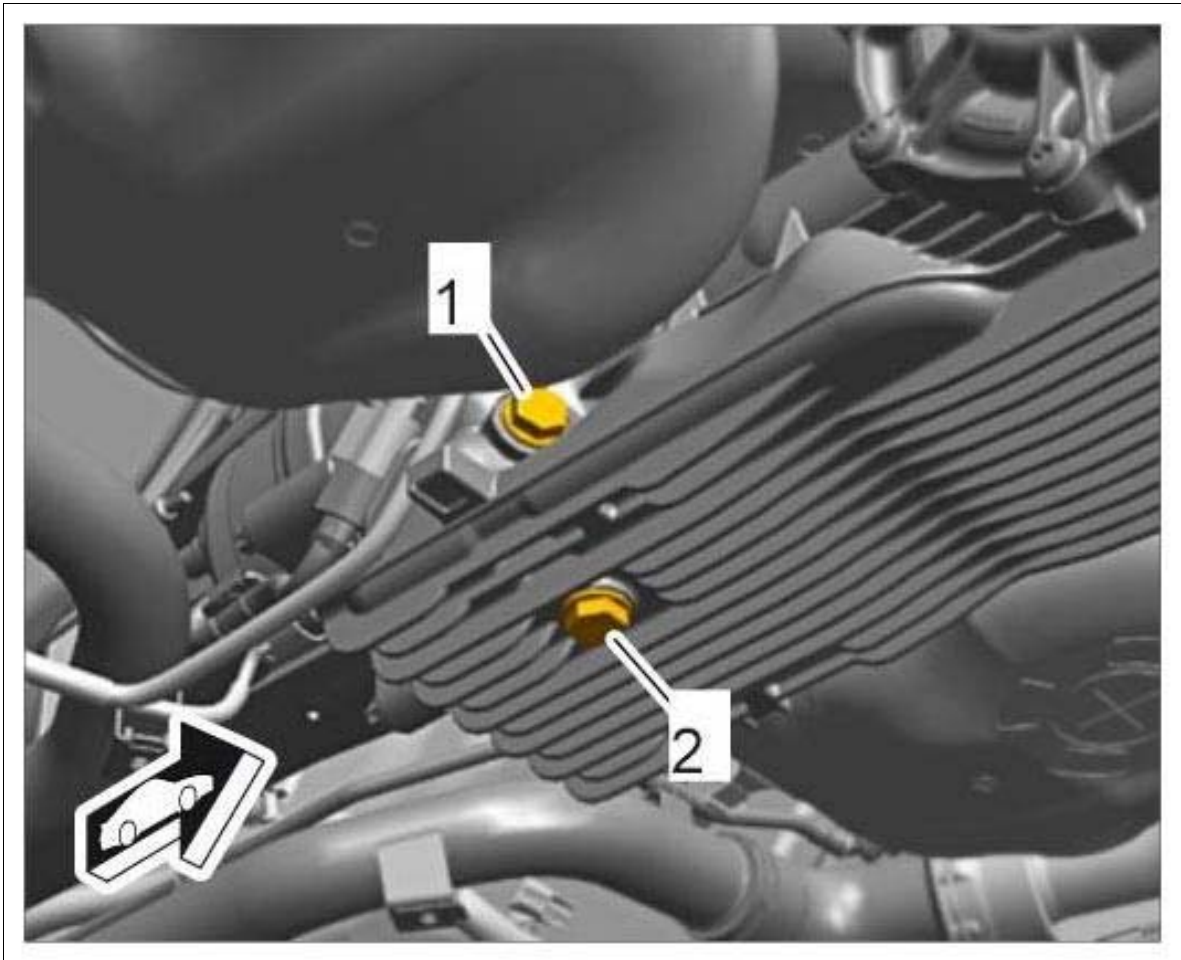

Courtesy of PORSCHE CARS NORTH AMERICA, INC.

2. Check oil level.

1. 2.1. The oil level is OK if clutch fluid emerges. Continue with Step 4.

2. 2.2. If clutch fluid does not emerge, the oil level in the final drive is too low. Continue with Step 3 .

3. Fill in clutch fluid up to the lower edge of the filler opening.

4. Clean filler screw and screw it in (for tightening torque, see Technical Values).

**WM 399035 CHECKING AND TOPPING UP OIL FOR FRONT FINAL DRIVE (GT3 RS) >
SUBSEQUENT WORK**

1. Install cover for front underbody.

→ 519219 REMOVING AND INSTALLING COVER FOR FRONT UNDERBODY .

2. Lower the vehicle.

WM 399035 CHECKING AND TOPPING UP OIL FOR FRONT FINAL DRIVE (GT3 RS) > TOOLS

Designation	Type	Number	Description
open-end/ring wrench insert	Commercially available tool	Nr.98-1 Pos.1	

WM 399035 CHECKING AND TOPPING UP OIL FOR FRONT FINAL DRIVE (GT3 RS) > TECHNICAL VALUES

Location	Description	Type	Basic value	Tolerance 1	Tolerance 2
Drain plug and filler screw for transmission oil for front final drive	M18 x 1.5 - replace sealing ring	Tightening torque	32 Nm (24 ftlb.)	+/-4 Nm (+/- 3 ftlb.)	
Drain plug and filler screw for transmission oil for front final drive	M18 x 1.5 - replace sealing ring	Tightening torque	32 Nm (24 ftlb.)	+/-4 Nm (+/- 3 ftlb.)	

WM 399035 CHECKING AND TOPPING UP OIL FOR FRONT FINAL DRIVE (GT3 RS) > PRELIMINARY WORK

Information

Only use oil approved by Porsche .

1. Jack and raise the vehicle at the prescribed jacking points.

→ 4X00IN LIFTING THE VEHICLE .

2. Remove cover for front underbody.

→ 519219 REMOVING AND INSTALLING COVER FOR FRONT UNDERBODY .

3. Place oil collection pan under the transmission.

WM 399035 CHECKING AND TOPPING UP OIL FOR FRONT FINAL DRIVE (GT3 RS) > CHECKING AND TOPPING UP OIL FOR FRONT FINAL DRIVE

Information

Only use **differential oil** approved by Porsche.

 **WARNING: Hot fluid**

- *Danger of scalding*

→ Let the fluid cool down.

→ Wear personal protective gear.

1. Unscrew filler screw **-2-** .

1. 1.1. Replace sealing ring and clean the filler screw.

Fig 1: Installing Drain Plug And Filler Screw For Differential Oil

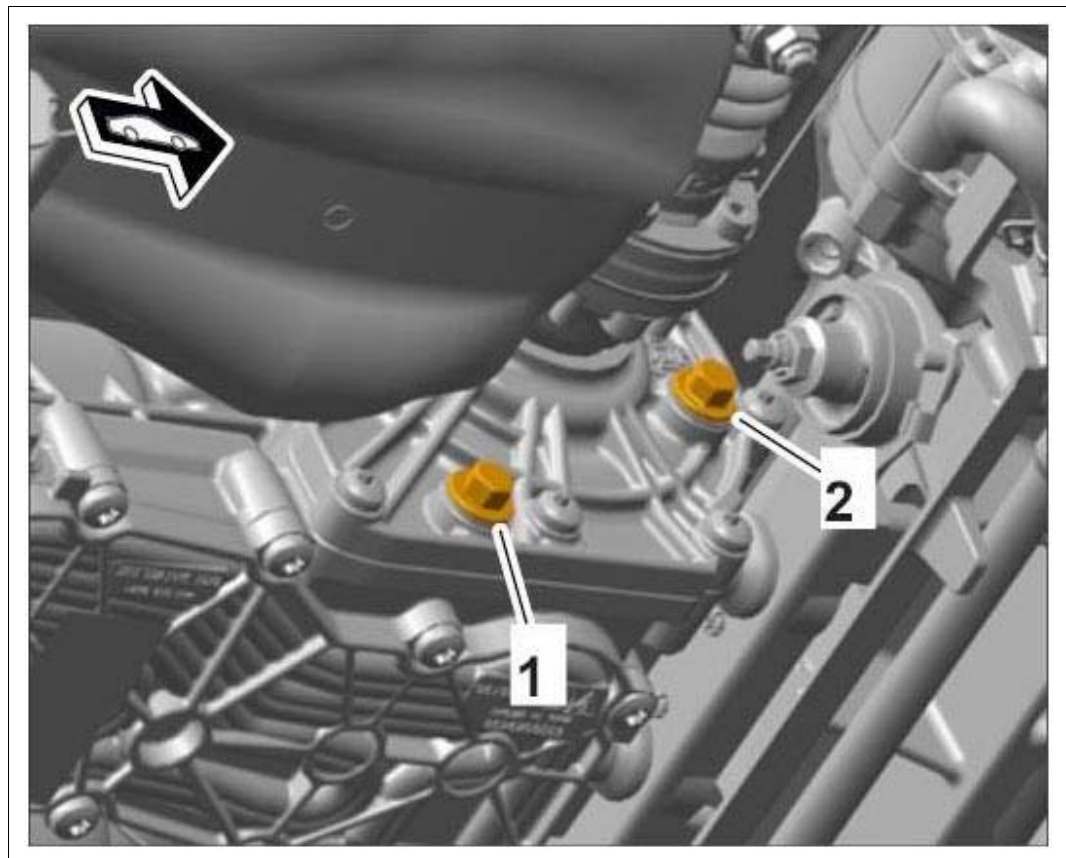

Courtesy of PORSCHE CARS NORTH AMERICA, INC.

2. Check oil level.

1. 2.1. The oil level is OK if differential oil emerges. Continue with Step 4.

2. 2.2. If no differential oil emerges, the oil level in the final drive is too low. Continue with Step 3 .

3. Fill in differential oil up to the lower edge of the filler opening.

4. Screw in filler screw with a new sealing ring and tighten it.

Tightening torque 32 Nm (24 ftlb.) +/-4 Nm (+/-3 ftlb.)

5. Remove residual traces of oil from the transmission.

WM 399035 CHECKING AND TOPPING UP OIL FOR FRONT FINAL DRIVE (GT3 RS) > CHECKING AND TOPPING UP OIL FOR FRONT FINAL DRIVE > CHECKING AND TOPPING UP OIL FOR ELECTROMAGNETIC CLUTCH

Information

Only use **clutch fluid** approved by Porsche .

 **WARNING: Hot fluid**

- *Danger of scalding*

→ Let the fluid cool down.

→ Wear personal protective gear.

1. Unscrew filler screw **-2-** .

1. 1.1. Replace sealing ring and clean the filler screw.

Fig 1: Installing Drain Plug And Filler Screw For Clutch Fluid

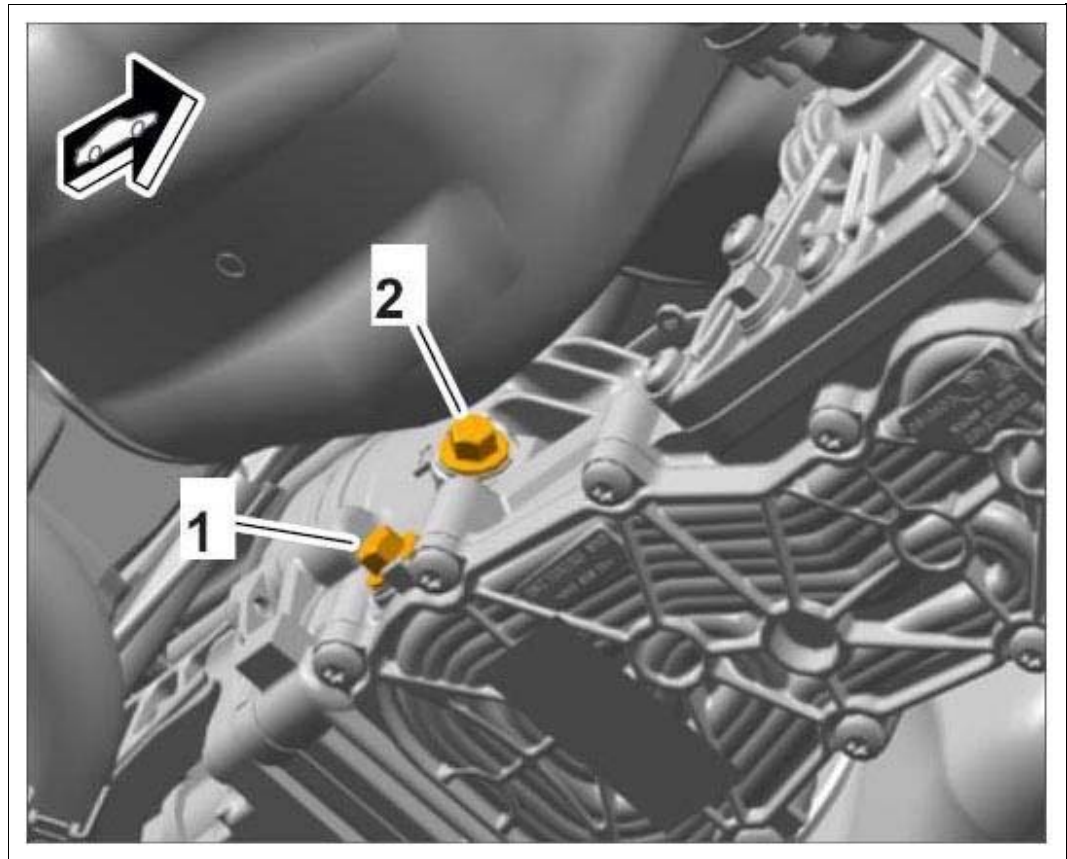

Courtesy of PORSCHE CARS NORTH AMERICA, INC.

2. Check oil level.

1. 2.1. The oil level is OK if clutch fluid emerges. Continue with Step 4.

2. 2.2. If clutch fluid does not emerge, the oil level in the final drive is too low. Continue with Step 3 .

3. Fill in clutch fluid up to the lower edge of the filler opening.

4. Screw in filler screw with a new sealing ring and tighten it.

Tool recommendation: 3/8-inch torque wrench with open-end/ring wrench insert Nr.98-1 Pos.1

Tightening torque 32 Nm (24 ftlb.) +/-4 Nm (+/-3 ftlb.)

5. Remove residual traces of oil from the transmission.

WM 399035 CHECKING AND TOPPING UP OIL FOR FRONT FINAL DRIVE (GT3 RS) > SUBSEQUENT WORK

1. Install cover for front underbody.

→ 519219 REMOVING AND INSTALLING COVER FOR FRONT UNDERBODY .

2. Lower the vehicle.