

Porsche, the Porsche Crest, Panamera, PCCB, PCM, PDK, PSM and Tequipment are registered trademarks of Dr. Ing. h.c. F. Porsche AG.

Printed in Germany.

Reprinting (including excerpts) as well as all other forms of reproduction are prohibited without the written permission of Dr. Ing. h.c. F. Porsche AG.

© Dr. Ing. h.c. F. Porsche AG  
Porscheplatz 1  
70435 Stuttgart Germany

### On-board literature

Keep the on-board literature in the vehicle at all times and if you ever come to sell your vehicle, please hand it over to the new owner.

### Suggestions

Do you have any questions, suggestions or ideas about your vehicle or the on-board literature?

Please write to us:

Dr. Ing. h.c. F. Porsche AG  
Vertrieb Customer Relations  
Porschestraße 15-19  
71634 Ludwigsburg Germany

### Equipment

There may be some differences in equipment and technology with respect to the illustrations and descriptions due to the ongoing development of the systems and the varying laws in individual countries.

The equipment versions shown are not always included as standard. Some of the functions described in this operating manual are optional equipment and may not be available in your PCM. If this is the case, the relevant menu items will not be available to you.

### Safety instructions in this manual

This manual uses different types of safety instructions.



#### Death or serious injury.

Failure to observe safety instructions in the “Danger” category will lead to serious injury or death.

---



#### Possible death or serious injury.

Failure to observe safety instructions in the “Warning” category could lead to serious injury or death.

---



#### Possible moderate or minor injury.

Failure to observe safety instructions in the “Caution” category could lead to moderate or minor injury.

---



#### Possible vehicle damage.

Failure to observe safety instructions in the “Note” category could lead to damage to the device.

---

 Additional information and tips to be observed ...

# Contents

<b>Using the PCM.....</b>	<b>5</b>	<b>PHONE .....</b>	<b>50</b>	<b>CAR .....</b>	<b>100</b>
Important information on operation and road safety .....	5	Bluetooth® .....	50	Trip data display .....	100
Introduction to operation .....	5	Operating the Bluetooth® hands-free unit (Bluetooth® mobile phone preparation) .....	52	Hybrid display (not available for sports cars).....	101
Menu types and options for operation.....	9	Telephone settings (Bluetooth® mobile phone preparation) .....	60	ParkAssist .....	102
Sound settings .....	12	Bluetooth® settings (Bluetooth® mobile phone preparation) .....	61	Rear view camera (not available for sports cars).....	104
Sound settings with BOSE® Surround Sound System .....	13	Phonebook settings (Bluetooth® mobile phone preparation) .....	63	Logbook .....	108
Sound settings with Burmester® High-End Surround Sound System (Panamera and Cayenne).....	13	Transferring the phonebook.....	64	The Sport display.....	115
Sound settings with Burmester® High-End Surround Sound System (Carrera, Boxster and Cayman) .....	14	Operating the PCM telephone.....	65	Extended memory.....	121
Configuring the PCM display .....	15	Text messages (SMS) (with PCM telephone only) .....	74	<b>NAVI .....</b>	<b>126</b>
Setting the display unit for temperatures .....	16	Telephone settings (PCM telephone) .....	80	General operation .....	126
<b>TUNER.....</b>	<b>19</b>	Call settings (PCM telephone) .....	83	Entering an address .....	127
Radio .....	19	Bluetooth® settings (PCM telephone) .....	85	Starting/stopping route guidance .....	128
Making settings for radio mode.....	22	Phonebook settings .....	87	List of previous destinations .....	129
TV .....	24	Settings for messages and data (PCM telephone) .....	88	Personal destination memory .....	131
Making settings for TV mode .....	27	Cordless handset.....	89	Points of interest .....	135
<b>MEDIA.....</b>	<b>31</b>	<b>INFO .....</b>	<b>96</b>	Changing options for route guidance .....	136
CD audio/DVD-Audio/DVD-Video .....	31	Displaying traffic messages (TMC).....	96	Stopovers (tour).....	139
iPod.....	37	Displaying sections of the route .....	98	Destination input using geographical coordinates .....	141
USB.....	40	Displaying information about the location .....	98	Destination input using the map.....	142
External audio source.....	44	Displaying detailed information about the active audio source .....	98	Storing.....	142
External Bluetooth® audio source .....	45			Off-road navigation .....	143
Bluetooth® settings .....	46			Reloading data.....	147

**MAP ..... 149**

Changing the scale of the map..... 149  
Moving the map..... 149  
Setting 3D display..... 149  
Displaying traffic messages..... 149  
Setting the display of the total route..... 150  
Setting autozoom ..... 150  
Displaying Destination town/Location ..... 150  
Operating the map menu using symbols ..... 150  
Displaying sections of the route ..... 151  
Setting the display layout..... 151  
Compiling map contents..... 152

**Voice control ..... 155**

How voice control works ..... 155  
Symbols in sample dialogues..... 156  
Commands..... 156  
Basic voice control functions ..... 157  
Using the help function..... 159  
Operating examples ..... 161

**Index ..... 174**

**Technical data..... 182**

Radio frequency ranges..... 182  
Tuning steps used during  
automatic station search ..... 182  
Regional codes for video DVDs ..... 182  
Affiliated countries for  
TV tuner country settings..... 182

# Using the PCM

Important information on operation and road safety .....	5	Sound settings with Burmester® High-End Surround Sound System (Panamera and Cayenne) .....	13
Introduction to operation .....	5	Setting the listening position.....	13
Switching the PCM on/off.....	5	Setting smooth.....	13
Setting the volume .....	6	Setting surround.....	14
Muting .....	6	Setting live.....	14
Selecting the audio source.....	6	Setting sound conditioner .....	14
Controls and their functions.....	7	Sound settings with Burmester® High-End Surround Sound System (Carrera, Boxster and Cayman) .....	14
Menu types and options for operation.....	9	Setting smooth.....	14
What are the menu types? .....	9	Setting surround.....	14
Calling up and operating menu types .....	9	Setting live.....	15
Exiting menus .....	10	Configuring the PCM display .....	15
Operating lists.....	10	Configuring display settings .....	15
Operating input menus .....	10	Setting the language.....	16
Sound settings .....	12	Setting the units .....	16
Setting the bass.....	12	Setting the display unit for temperatures .....	16
Setting the treble .....	12	Resetting personal settings .....	17
Setting the balance.....	12		
Setting the fader .....	12		
Setting the loudness .....	12		
Setting SDV (speed-dependent volume) .....	12		
Sound settings with BOSE® Surround Sound System .....	13		
Setting surround .....	13		
Setting linear .....	13		
Setting AudioPilot®.....	13		

## Important information on operation and road safety

The **PCM (Porsche Communication Management)** system is the central control unit for the radio, the TV tuner, media operation (CD/DVD, USB, iPod, and an external audio source), the sound settings, the on-board computer, the navigation and the telephone.

To avoid danger or injury to yourself and others while using your PCM, you must take the following into consideration:

### WARNING

#### **Accident hazard. Distraction could result in you losing control of the vehicle.**

- ▷ Operate your PCM only when you are safely in control of your vehicle and traffic conditions permit. If in doubt, stop the vehicle and operate the PCM while the vehicle is parked.

### CAUTION

#### **Injury hazard. Opening the housing or a damaged housing represents a hazard due to invisible laser radiation.**

- ▷ The PCM is a Class 1 laser product. Do not open the housing.  
The PCM does not contain any user-serviceable parts. Any maintenance work must be performed exclusively by qualified service experts.

### WARNING

**Accident hazard. The navigation system is only intended as an aid to the driver and makes recommendations on the routes to take. This does not release you from full responsibility for observing road safety, traffic conditions, legal road traffic regulations and any other relevant regulations while driving your vehicle.**

**As the driver, you must assess the traffic situation. You have sole responsibility for road safety while driving your car.**

- ▷ Continue to pay attention to the traffic situation.

### WARNING

**Injury hazard. The telephone must not be used near explosives or flammable materials (e.g. at a petrol station) or near operations involving explosives.**

**Mobile phones must be switched off in certain hazardous areas such as near petrol stations, fuel depots, chemical plants and demolition work in progress using explosives, for example. They can interfere with technical equipment.**

- ▷ Please heed appropriate warnings.
- ▷ Observe statutory regulations and local restrictions when using the telephone.

## Introduction to operation

### Switching the PCM on/off

**Switching on/off via the ignition (permanently)**

- ▷ Switch on the ignition.

The PCM is permanently active.

**Switching on/off via the left rotary knob**

If the PCM is not to be permanently active, you can also switch it on/off using the left rotary knob.

- ▷ Press and hold the left rotary knob (volume control) for at least one second.

### Battery discharge protection

Switching on/off via the left rotary knob is also possible when the ignition is off.

To protect your vehicle's battery, the PCM will automatically switch itself off again after a few minutes.

## NOTICE

### Risk of damage. The PCM contains high-quality electronic components which require special care with regard to maintenance.

The following should be observed:



- The display is sensitive to scratches.
  - The device must not be sprayed with liquids. Ingress of liquids can result in the destruction of the equipment.
  - ▷ Carefully clean your PCM periodically using a dry, clean and soft cloth (microfibre cloth) or a cleaning brush.
  - ▷ Do not exert excessive pressure on the surface when cleaning.
  - ▷ **Under no circumstances** may solvents such as methylated spirits, thinners, petrol, acetone or alcohol (ethanol, methanol or isopropyl alcohol) or scouring agents of any type be used.
  - ▷ Remove fingerprints using a slightly damp cloth or a mild cleaning agent.
  - ▷ **Never** spray cleaning agents or other liquids directly onto the display. Instead dampen a cloth and carefully wipe the display clean.
  - ▷ If faults occur, do not open the PCM equipment yourself **under any circumstances**. Always have defective devices repaired by a qualified specialist workshop. We recommend that this work be performed by a Porsche partner, as Porsche partners have trained workshop personnel as well as the necessary parts and tools.
- 

### Setting the volume

- ▷ Turn the left rotary knob .  
Depending on the situation, this adjusts the volume for:
  - the active audio source,
  - a traffic announcement,
  - a voice control system announcement,
  - the ringtone during an incoming call,
  - hands-free mode during a telephone call.

### Muting

#### Muting an audio source

- ▷ Briefly press the left rotary knob .  
This mutes the active audio source. The mute symbol  is shown in the bottom line. However, navigation recommendations, telephone calls and traffic announcements continue to be audible.

### Cancelling muting

- ▷ To cancel muting, briefly press the left rotary knob  again.

### Muting navigation or traffic announcements

- ▷ To interrupt a navigation or traffic announcement, briefly press the left rotary knob  during the announcement.

### Selecting the audio source

Pressing the **SOURCE** button opens a window where you can set the current audio source.

The window closes again as soon as:

- you have set an audio source or
- several seconds pass and you have made no entry.

1. Press the **SOURCE** button.
2. Select the audio source you want on the display.

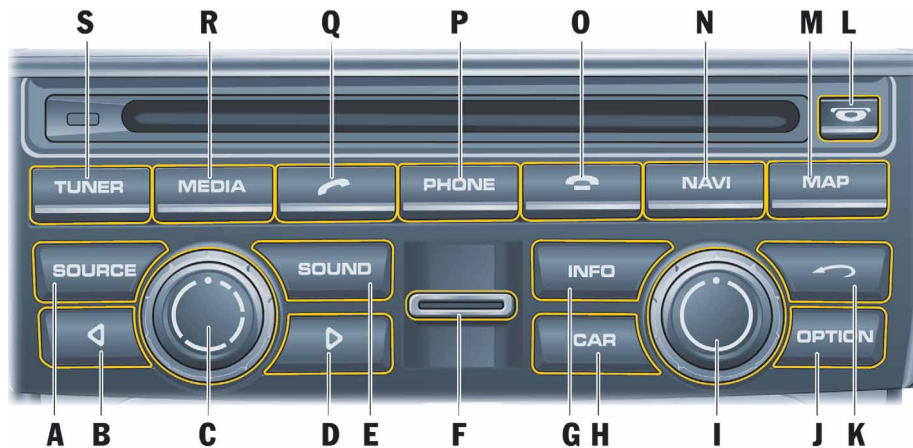

## Controls and their functions

The controls for the PCM are arranged below the display and around the CD/DVD slot.

A **SOURCE** button

B ◀ arrow button

C Left rotary knob

⦿: Sets the volume

→ (press briefly): Switches on or mutes the device

→ (press and hold): Switches the device on and off

D ▶ arrow button

E **SOUND** main menu button

F Slot for SIM card

G **INFO** main menu button

H **CAR** main menu button

I Right rotary knob

⦿: Highlights a menu item

→: Selects the highlighted menu item

J **OPTION** button

K Back button

L Eject/retract button for CDs and DVDs



M **MAP** main menu button

N **NAVI** main menu button

O End call button

P **PHONE** main menu button

Q Lift handset button

R **MEDIA** main menu button

S **TUNER** main menu button

## A - SOURCE button

Pressing the **SOURCE** button opens a window where you can set the current audio source.

The window closes again when:

- you have set an audio source,
- several seconds pass and you have made no entry.

## B - ◀ arrow button

By briefly pressing the arrow button you can:

- start a search downwards in radio or TV mode,
- skip a track in CD/DVD, USB or iPod mode.

Pressing the arrow button for several seconds in CD/DVD mode starts fast reverse.

## C - Left rotary knob

Pressing and holding the left rotary knob switches the device on or off.

Turning the left rotary knob changes the following settings:

- volume of the active audio source,
- volume of a traffic announcement,
- volume of a voice control system announcement,
- volume when in hands-free mode during a telephone call,
- ringtone volume of the telephone during an incoming call,
- cancelling muting (turning the rotary knob clockwise).

Briefly pressing the left rotary knob  executes the following functions:

- cancels navigation and traffic announcements,
- rejects an incoming telephone call,
- mutes the device,
- switches on the system.

#### **D - ▷ arrow button**

By briefly pressing the arrow button you can:

- start a search upwards in radio or TV mode,
- skip a track in CD/DVD, USB or iPod mode.

Pressing the arrow button for several seconds in CD/DVD mode starts fast forward.

#### **E - SOUND main menu button**

Pressing the **SOUND** button opens a menu where you can make the sound settings for the PCM.

#### **F - Slot for the telephone SIM card**

To use the internal telephone, you must insert the SIM card in the slot provided.

Alternatively, the SIM card of a mobile phone with the *Bluetooth*<sup>®</sup> SIM Access Profile can be used.

#### **G - INFO main menu button**



Pressing the **INFO** button displays various general information such as the current audio source, the date and time and the signal strength for your telephone network.

#### **H - CAR main menu button**

Pressing the **CAR** button opens an overview of various trip data.

#### **I - Right rotary knob**

Along with the touchscreen, the right rotary knob is the central control:

- Turn the rotary knob  to highlight the menu item you want.
- Press  to select a highlighted menu item.

#### **J - OPTION button**

Since not all of the operating options for a main menu can be shown on one display, the **OPTION** menu summarises various operating options for the main menus. You call up these operating options by pressing the **OPTION** button.

 Instead of pressing the button you can also touch the tab of the same name on the display.

#### **K- Back button**

By pressing the Back button  you can execute various functions.

Briefly press the button to:

- undo a selection in the menu,
- cancel a list selection.

Press and hold the button to:

- delete all characters already entered into an input menu.

#### **L - Eject button**

Pressing the  button executes the following functions depending on the equipment of your PCM:

PCM without CD/DVD changer

- A CD or DVD inserted in the drive is ejected so it can be removed.

PCM with CD/DVD changer

- The CD/DVD changer menu is opened. Pressing the button again ejects the highlighted CD or DVD so it can be removed.
- If you press the button for several seconds and there are still no CDs/DVDs in the changer compartments, you will be prompted to fill the individual compartments one after the other.
- If you press the button for several seconds and the magazine compartments are at least partially full, all CDs or DVDs are ejected one after the other.



### **M - MAP** main menu button

Pressing the **MAP** button opens the map view of the navigation function.

### **N - NAVI** main menu button

Pressing the **NAVI** button opens the menu of the navigation function.

### **O - End call** button

By pressing the End call button  you can:

- reject an incoming telephone call or
- end an active call.

### **P - PHONE** main menu button

Pressing the **PHONE** button opens the menu of the telephone function.

### **Q - Lift handset** button

By pressing the Lift handset button  you can:

- accept an incoming telephone call or
- call up the quick dial function.

### **R - MEDIA** main menu button

Pressing the **MEDIA** button opens the menu for operating the CD, DVD, iPod, USB, AUX and AUX BT audio sources.

### **S - TUNER** main menu button

Pressing the **TUNER** button opens the menu for radio mode.

## **Menu types and options for operation**

The PCM display is a colour touchscreen. All menu functions, list entries and text input fields as well as the arrow symbols and scrollbars can be operated by lightly touching the corresponding location on the display.

### **What are the menu types?**

#### **Main menu**

The range of functions of the PCM is divided between the following main menus:

- **TUNER** : radio main menu,
- **MEDIA** : disc main menu,
- **PHONE** : telephone main menu,
- **NAVI** : navigation main menu,
- **MAP** : map view,
- **SOUND** : sound settings,
- **INFO** : information menu as well as
- **CAR** : vehicle and trip data main menu.

Each of these main menus contains various submenus for a specific topic.

#### **Option menus**

Each of the eight main menus has an option menu where you find settings and other functions for the respective main menu.

## **Calling up and operating menu types**

### **Calling up main menus**

- ▷ To call up a main menu, press the appropriate button below the display.

You can switch from one main menu to another at any time.

When you return to a main menu, you return to the function you were using before exiting the menu.

If you want to return to the top level of a main menu, you must press the relevant main menu button twice in succession.

### **Calling up option menus**

- ▷ To call up an option menu, press the **OPTION** button.

- or -

- ▷ Touch the tab on the display with your finger.

### **Operating menus with the touchscreen**

- ▷ Touch the individual menu items or symbols directly on the display.

**i** If the menu functions cannot be operated by touching the display, it is because the touchscreen is deactivated. For further information, see „SWITCHING THE TOUCHSCREEN ON/OFF“ on page 15.

## Operating menus with the right rotary knob

Instead of operation on the touchscreen, you can also operate the menu items with the right rotary knob.

- ▷ Turn the right rotary knob (🕒) to highlight a menu item.
- ▷ Press →🕒 the right rotary knob to activate the highlighted menu item.

**i** The process of highlighting (🕒) and activating →🕒 using the right rotary knob **or** touching the menu item on the display is referred to below as “**selecting**”.

## Exiting menus

### Returning to the next highest menu

- ▷ Press the Back button (↩) to cancel an operation and return to the next highest menu.

### Returning to the main menu

- ▷ Press a main menu button to return to the corresponding main menu.

### Returning to the top level of a main menu

- ▷ Briefly press the appropriate main menu button twice in succession to return to the top level of the main menu.

## Operating lists

The following operating options are available to you for selecting a list entry:

- ▷ Touch the symbols (▲) and (▼) on the display.

- or -

- ▷ Touch the scrollbar between the two symbols (▲) and (▼).

- or -

- ▷ Turn the right rotary knob (🕒).

Highlighted list entries are framed in orange.

### Showing the first letter of list entries

To make it easier to find your way in long lists, you can show the first letter of list entries in the following lists:

- the phonebook,
- the list for the music search in the iPod or in USB mode,
- the track list in USB and MP3 disc mode or
- the destination memory in the navigation menu.

- ▷ Touch and hold one of the two symbols (▲) and (▼) for several seconds.

- or -

- ▷ Quickly turn the right rotary knob (🕒).

**i** Only letters with corresponding entries in the list will be displayed.



## Operating input menus

In many cases you can enter data into the PCM. This can be the case when entering an SMS message, a telephone number or a navigation destination, for example. The various input menus are customised to their respective operating situations.

- ▷ To enter data into an input menu, lightly touch the characters on the display.

- or -

- ▷ Highlight the characters by turning the right rotary knob (🕒) and insert them by pressing the right rotary knob →🕒.

- ▷ To confirm and accept the data you have entered, select **OK**.

In addition to the letter fields, the input menus also provide a number of function fields for changing the character set displayed and for moving the cursor:



deletes the last character entered (if button is touched briefly)

- **or** -

deletes all characters entered (if button is touched and held)



switches to positioning mode when composing text messages (SMS)

ABC

switches to uppercase

abc

switches to lowercase

123

switches to numbers and punctuation marks

@&#

switches to special characters



switches to insertion mode when composing a text message



inserts a period



inserts a comma



inserts a colon

SPACE

inserts a space

CLEAR

deletes **all** entries in the input field

List

calls up a stored list, for example when entering an address in the navigation system

OK

confirms the input and closes the input menu

Greyed out characters cannot be selected.

**i** In many cases the input menus are pre-sorted. This means that after you have entered at least three letters, only the letters for which there is an entry in a list are offered for selection.

### Setting the layout for the keyboard of the input menu



The letter fields in the input menu can either be arranged alphabetically or like a computer keyboard.

1. Press the **CAR** button.
2. Press the **OPTION** button or touch the tab of the same name in the header.
3. Select **"SET PCM system"**
  - > **"Display PCM"**
  - > **"Keyboard layout"**.
4. Select one of the two options:
  - **"ABC"**:  
The letter fields are arranged alphabetically.
  - **"QWERTY/QWERZ"**:  
The letter fields are arranged like a computer keyboard.  
The chosen keyboard layout is set.



## Sound settings

You can set the sound of your PCM for each audio source separately using the sound settings in the Sound menu. As soon as an audio source is selected, its sound settings are set automatically. The range of displays and functions for the sound settings depends on the vehicle type and the equipment installed. In some cases, therefore, not all of the functions described here may be available.

### Setting the bass



1. Press the **SOUND** button.
2. Select “**Bass**”.
3. Make the setting you want by touching the two symbols  and  or by turning  the right rotary knob.

### Setting the treble

1. Press the **SOUND** button.
2. Select “**Treble**”.
3. Make the setting you want by touching the two symbols  and  or by turning  the right rotary knob.



### Setting the balance

The **Balance** setting allows you to set the volume distribution between the left and right speakers.

1. Press the **SOUND** button.
2. Select “**Balance**”.
3. Make the setting you want by touching the symbols  and  or by turning  the right rotary knob.

### Setting the fader

The **Fader** setting allows you to set the volume distribution between the front and rear speakers.

1. Press the **SOUND** button.
2. Select “**Fader**”.
3. Make the setting you want by touching the symbols  and  or by turning  the right rotary knob.

### Setting the loudness



“**Loudness**” increases the sound volume by increasing the bass and treble frequencies. This setting is particularly effective for low volumes and guarantees a pleasant sound.

1. Press the **SOUND** button.
2. Select “**Loudness**” to activate  or deactivate  the function.

### Setting SDV (speed-dependent volume)

The “**SDV**” function automatically adjusts the audio playback volume as a function of the vehicle’s speed.

You can set the degree to which the volume adjusts to the vehicle’s speed on a scale from 0 (no increase in volume) to 5 (large increase in volume).

1. Press the **SOUND** button.
2. Press the **OPTION** button or touch the tab of the same name in the header.
3. Select “**SDV**”.
4. Make the setting you want by touching the symbols  and  or by turning  the right rotary knob.

## Sound settings with BOSE® Surround Sound System

### Setting surround

Activating “**Surround**” achieves a sound setting with greater spatial depth.

This permits the creation of a virtual surround sound with conventional stereo sources such as CDs, radio or MP3 formats, for example.

The function can be set separately for the individual audio sources.

The “**Surround**” function is generally activated with multi-channel sources such as 5.1 DVDs, for example.

It cannot be activated for the sources “**AM**” and “**TV**”.

1. Press the **SOUND** button.
2. Press the **OPTION** button or touch the tab of the same name in the header.
3. Select “**Surround**” to activate (☑) or deactivate (☐) the function.

### Setting linear

Selecting “**Linear**” switches the PCM from a bass-heavy setting (linear off) to a more neutral sound (linear on).

1. Press the **SOUND** button.
2. Press the **OPTION** button or touch the tab of the same name in the header.
3. Select “**Linear**” to activate (☑) or deactivate (☐) the function.

### Setting AudioPilot®

If the “**AudioPilot**” function is activated, the noise level inside the vehicle is monitored. Background noise is analysed and the volume and dynamics of the music playback across the entire frequency spectrum is automatically adjusted.

1. Press the **SOUND** button.
2. Press the **OPTION** button or touch the tab of the same name in the header.
3. Select “**AudioPilot**” to activate (☑) or deactivate (☐) the function.

## Sound settings with Burmester® High-End Surround Sound System (Panamera and Cayenne)

### Setting the listening position

The “**Listening position**” setting allows you to optimise the sound settings for the front or rear seats.

If, on the other hand, you select the symmetrical setting, you achieve the best possible sound setting taking all seats into account.

1. Press the **SOUND** button.
2. Select “**Listening position**”.
3. Select one of the following settings:
  - “**Front**”,
  - “**Symmetrical**” or
  - “**Rear**”.

### Setting smooth

The “**Smooth**” function is used to precisely reduce overemphasized frequencies in the midrange and treble, which may be present in highly compressed music material. Typical examples include playing MP3 files with a low data rate or listening to an FM station with unfavourable reception conditions.

This function facilitates a relaxing, pleasant listening experience for these sources over a long period.

1. Press the **SOUND** button.
2. Press the **OPTION** button or touch the tab of the same name in the header.
3. Select “**SET Burmester**”.
4. Select “**Smooth**” to activate () or deactivate () the function.

### Setting surround

Activating “**Surround**” achieves a sound setting with greater spatial depth.

This permits the creation of a virtual surround sound with conventional stereo sources such as CDs, radio or MP3 formats, for example.

The function can be set separately for the individual audio sources. The listening position is then set to “**Symmetrical**”.

The “**Surround**” function is generally activated with multi-channel sources such as 5.1 DVDs, for example.

It cannot be activated for the sources “**AM**” and “**TV**”.

1. Press the **SOUND** button.
2. Press the **OPTION** button or touch the tab of the same name in the header.
3. Select “**SET Burmester**”.
4. Select “**Surround**” to activate () or deactivate () the function.

### Setting live

The “**Live**” function generates surround sound that sounds just like a live concert from any stereo music signal. The listening position is set to “**Symmetrical**” for this.

1. Press the **SOUND** button.
2. Press the **OPTION** button or touch the tab of the same name in the header.
3. Select “**SET Burmester**”.
4. Select “**Live**” to activate () or deactivate () the function.

### Setting sound conditioner

If the “**Sound conditioner**” function is activated, the noise level inside the vehicle is monitored.

Background noise is analysed and the volume and dynamics of the music playback across the entire frequency spectrum is automatically adjusted.

1. Press the **SOUND** button.
2. Press the **OPTION** button or touch the tab of the same name in the header.
3. Select “**SET Burmester**”.
4. Select “**Sound conditioner**” to activate () or deactivate () the function.

## Sound settings with Burmester® High-End Surround Sound System (Carrera, Boxster and Cayman)

### Setting smooth

The “**Smooth**” function is used to precisely reduce overemphasized frequencies in the midrange and treble, which may be present in highly compressed music material. Typical examples include playing MP3 files with a low data rate or listening to an FM station with unfavourable reception conditions.

This function facilitates a relaxing, pleasant listening experience for these sources over a long period.

1. Press the **SOUND** button.
2. Press the **OPTION** button or touch the tab of the same name in the header.
3. Select “**SET Burmester**”.
4. Select “**Smooth**” to activate () or deactivate () the function.

### Setting surround

Activating “**Surround**” achieves a sound setting with greater spatial depth.

This permits the creation of a virtual surround sound with conventional stereo sources such as CDs, radio or MP3 formats, for example.

The function can be set separately for the individual audio sources.

The “**Surround**” function is generally activated with multi-channel sources such as 5.1 DVDs, for example.

It cannot be activated for the sources “**AM**” and “**TV**”.

1. Press the **SOUND** button.
2. Press the **OPTION** button or touch the tab of the same name in the header.
3. Select “**SET Burmester**”.
4. Select “**Surround**” to activate (☑) or deactivate (☐) the function.

### Setting live

The “**Live**” function generates surround sound that sounds just like a live concert from any stereo music signal.

The listening position is set to “**Symmetrical**” for this.

1. Press the **SOUND** button.
2. Press the **OPTION** button or touch the tab of the same name in the header.
3. Select “**SET Burmester**”.
4. Select “**Live**” to activate (☑) or deactivate (☐) the function.

### Setting sound conditioner

If the “**Sound conditioner**” function is activated, the noise level inside the vehicle is monitored.

Background noise is analysed and the volume and dynamics of the music playback across the entire frequency spectrum is automatically adjusted.

1. Press the **SOUND** button.
2. Press the **OPTION** button or touch the tab of the same name in the header.
3. Select “**SET Burmester**”.
4. Select “**Sound conditioner**” to activate (☑) or deactivate (☐) the function.

## Configuring the PCM display

You can set various units, the welcome display and the user language of the PCM in the “**SET PCM system**” menu.

### Configuring display settings

#### Switching the display off

You can switch off or darken the display using the “**Switch off display**” menu.

1. Press the **CAR** button.
2. Press the **OPTION** button or touch the tab of the same name in the header.
3. Select “**SET PCM system**”
  - > “**Display PCM**”
  - > “**Screen**”.
4. Select “**Switch off display**”.
5. Confirm the prompt that appears.

#### Switching the display back on

You can switch a display that is off back on at any time (if the touchscreen is active) by touching it.

- ▷ Touch anywhere on the screen with your finger.
- or -
- ▷ Press any button.

### Choosing the brightness of the display

1. Press the **CAR** button.
2. Press the **OPTION** button or touch the tab of the same name in the header.
3. Select “**SET PCM system**”
  - > “**Display PCM**”
  - > “**Screen**”
  - > “**Brightness**”.
4. You can set the brightness by selecting the two symbols ▼ and ▲.

### Switching the touchscreen on/off

1. Press the **CAR** button.
2. Press the **OPTION** button or touch the tab of the same name in the header.
3. Select “**SET PCM system**”
  - > “**Display PCM**”.
4. Select “**Touchscreen off**” to activate (☑) or deactivate (☐) the function.

### Choosing colours for the map view (day/night design)

1. Press the **CAR** button.
2. Press the **OPTION** button or touch the tab of the same name in the header.
3. Select “**SET PCM system**”
  - > “**Display PCM**”.

#### 4. Select “Day/night switchover”.

The following options are then available for you to select:

##### – “Automatic”

Your PCM automatically switches from day design to night design as a function of the vehicle lighting.

##### – “Day”

Your PCM always remains set to the day design colours. This means the display colours are optimised for legibility.

##### – “Night”

Your PCM always remains set to the night design colours. The display colours are dimmed to prevent glare.

#### 5. Set the option you want by selecting it.

#### Setting the temperature or time display in the footer

##### 1. Press the **CAR** button.

##### 2. Press the **OPTION** button or touch the tab of the same name in the header.

##### 3. Select “SET PCM system” > “Display PCM”

> “Footer (temp./time)”.

##### 4. Select one of the two options:

##### – “Temperature”:

The exterior temperature will be displayed on the right in the footer.

##### – “Time”:

The time will be displayed on the right in the footer.

#### Displaying the system version

You have the option of viewing the system version of your PCM.

##### 1. Press the **INFO** button.

##### 2. Press the **OPTION** button or touch the tab of the same name in the header.

##### 3. Select “System version”

The system version is displayed.

#### Setting the language

#### Adapting the language to the instrument cluster

##### 1. Press the **CAR** button.

##### 2. Press the **OPTION** button or touch the tab of the same name in the header.

##### 3. Select “SET PCM system” > “Language PCM”.

##### 4. Select “Automatic”.

The language of the instrument cluster is set.

**i** If the language of the instrument cluster is not available as a language in the PCM, the language “English GB” is set.

#### Selecting the language yourself

##### 1. Press the **CAR** button.

##### 2. Press the **OPTION** button or touch the tab of the same name in the header.

##### 3. Select “SET PCM system” > “Language PCM”.

##### 4. Select the language you want.

#### Setting the units

#### Adapting the units to the instrument cluster

##### 1. Press the **CAR** button.

##### 2. Press the **OPTION** button or touch the tab of the same name in the header.

##### 3. Select “SET PCM system” > “Units PCM”.

##### 4. Select “Automatic”.

The settings of the instrument cluster are set.

#### Setting the unit for consumption

##### 1. Press the **CAR** button.

##### 2. Press the **OPTION** button or touch the tab of the same name in the header.

##### 3. Select “SET PCM system” > “Units PCM” > “Consump.”.

##### 4. Select one of the following units:

- “l/100km”,
- “km/l”,
- “mpg” or
- “mpg (UK)”.

#### Setting the display unit for temperatures

##### 1. Press the **CAR** button.

##### 2. Press the **OPTION** button or touch the tab of the same name in the header.

##### 3. Select “SET PCM system” > “Units PCM” > “Temperature”.

##### 4. Select either “°C (Celsius)” or “°F (Fahrenheit)”.



## Resetting personal settings

This menu item allows you to reset settings you have previously made.

1. Press the **CAR** button.
2. Press the **OPTION** button or touch the tab of the same name in the header.
3. Select “**SET PCM system**”  
> “**Reset PCM**”.
4. Select one of the following options:
  - “**Factory settings**”  
Resets all settings to predefined values. Any data you entered (addresses, destinations and telephone numbers) is, however, retained.
  - “**Vehicle handover**”  
Resets all settings to predefined values and deletes the data you entered (addresses, destinations, telephone numbers, logbook as well as the recordings in the Sport display).
5. Confirm the relevant prompt by selecting “**Yes**”.

# TUNER

Radio .....	19
Calling up the main menu for radio mode .....	19
Tuning to stations.....	19
Storing stations on station buttons in the preset memories.....	20
Traffic programme (TP).....	21
Making settings for radio mode.....	22
Switching RDS on/off.....	22
Switching regionalisation on/off.....	22
Switching RDS radio text on/off.....	22
Choosing a PTY (programme type) filter .....	22
Setting sorting criteria for the FM station list .....	23
TV .....	24
Calling up the main menu for TV mode .....	24
Tuning to TV stations.....	24
Storing TV stations .....	25
Showing the information window.....	26
Video text .....	26
Electronic Programme Guide.....	27
Making settings for TV mode .....	27
Setting sorting of the station list.....	27
Setting the reception country .....	28
Setting TV picture parameters .....	28



## Radio

### Calling up the main menu for radio mode

- ▷ Press the **TUNER** button repeatedly until the mode you want (**AM - FM - TV**) is highlighted in the bottom line.

You will see the main menu for the chosen mode together with the station buttons. If there are already stations stored on the station buttons, the names or frequencies of these stations are displayed.

If the station tuned to is broadcasting RDS signals (RDS = Radio Data System) in FM mode, you will see the information contained in these signals (e.g. station name, programme type and radio text) above the station buttons.

To find out more, please refer also to the sections „SWITCHING RDS ON/OFF“ on page 22 and „SWITCHING RDS RADIO TEXT ON/OFF“ on page 22.

## Tuning to stations

You have the following options for tuning to a station:

- using the station buttons,
- using the station list,
- via a station search or
- entering the frequency directly.

### Tuning to stations using the station buttons

To be able to tune to a station using the station buttons, there must already be a station stored on a station button. To find out more, please refer to the section „STORING STATIONS ON STATION BUTTONS IN THE PRESET MEMORIES“ on page 20.

1. Press the **TUNER** button repeatedly until the mode you want is highlighted.
2. Briefly press the station button.  
The station stored on the station button is tuned to.

### Tuning to stations using the station list

The station list contains all the stations that can currently be received. It is only available in FM mode.

1. Press the **TUNER** button repeatedly until “**FM**” is displayed.
  2. Select “**Station list**”.  
The station list is opened. In addition to the station names, it also contains the respective programme types.  
The station currently tuned to is highlighted in colour.
  3. Select a station.
- Tuning to stations via a station search**
- ▷ Start a search by pressing the arrow buttons ◀ and ▶.  
The search stops at the next station in the waveband.



### Tuning to stations by entering the frequency directly

1. Press the **TUNER** button repeatedly until the mode you want is highlighted.
2. Press the **OPTION** button or touch the tab of the same name in the header.
3. Select **“Manual tune”**.  
The input menu is opened. The frequency of the current station is displayed.
4. Tune to the frequency using one of the following options:
  - Entering it directly by touching the number buttons.
  - or -
  - Tuning to the next station from the station list by touching the symbols ◀ and ▶ on the display.
  - or -
  - Tuning to the next station from the station list by touching the stations shown on the left and right on the display.
  - or -
  - Turning the rotary knob (⦿) to change the frequency upwards or downwards.

As soon as a valid frequency is input, it is tuned to.

### Tuning to stations by scanning

If you activate this function, each station found within the frequency range will be played for approx. 5 seconds.

1. Press the **TUNER** button repeatedly until the mode you want is highlighted.
2. Press the **OPTION** button or touch the tab of the same name in the header.
3. Select **“Start scan”**.  
Each station within the frequency range is played for approx. 5 seconds.
4. Select **“Stop scan”** to tune to the scanned station.

### Storing stations on station buttons in the preset memories

#### Setting the preset memory

There are six memory locations available in each of the preset memories. The preset memories for radio mode are:

- In FM mode:  
**FM 1, FM 2, FM 3, BEST FM** and **MIXED**.
- In AM mode:  
**AM 1, AM 2, AM 3** and **MIXED**.

**i** The PCM automatically fills the station buttons for the Best FM preset memory at regular intervals with the stations with the strongest reception.

**i** In contrast to all other preset memories, the **MIXED** preset memory can store stations from different modes. This means you can store stations from FM mode and AM mode as well as stations from TV mode here.

1. Press the **TUNER** button repeatedly until the mode you want (**FM - AM - TV**) is highlighted.
  2. Press the **OPTION** button or touch the tab of the same name in the header.
  3. Select **“Preset memory”**.  
The available preset memories are listed.
  4. Select the preset memory you want.
  5. Touch the **TUNER** tab in the header again.
- i** If you briefly touch the preset memory displayed in the main menu, you will likewise switch to another preset memory.

### Choosing a station in the station list and storing it

1. Press the **TUNER** button repeatedly until **“FM”** is displayed.
2. Select **“Station list”**.
3. Select the station entry you want by pressing and holding it for several seconds.  
The station buttons are displayed and the station previously chosen is shown in the information window.
4. To store the station on a station button, select the station button you want.  
The station list is displayed again.

### Storing via an automatic station search (autostore)

The automatic station search is only available for the preset memories **FM 1**, **FM 2**, **FM 3** as well as **AM 1**, **AM 2** and **AM 3**.

1. Press the **TUNER** button repeatedly until the mode you want (**FM - AM - TV**) is highlighted.
2. Set the preset memory if applicable (> page 20).
3. Press and hold the “**Autostore**” menu item. The search is activated. It stores the six stations with the strongest reception and tunes to the strongest station.

### Storing stations manually

1. Press the **TUNER** button repeatedly until the mode you want (**FM - AM - TV**) is highlighted.
2. Tune to the station (> page 19).
3. Set the preset memory if applicable (> page 20).
4. Press and hold the station button for a few seconds.

As soon as the station is stored on the station button, the station name or the station frequency is displayed on the button and you hear a signal tone.

### Traffic programme (TP)

Various FM radio stations broadcast traffic messages in addition to their radio programmes. The broadcasting stations are responsible for the quality of these traffic messages. For that reason, no liability can be accepted for the completeness and correctness of the information.

Traffic messages are part of the RDS signals and are not available everywhere. To find out more, please refer also to the sections „SWITCHING RDS ON/OFF“ on page 22 and „DISPLAYING TRAFFIC MESSAGES (TMC)“ on page 96.



### Switching the traffic programme on

1. Press the **TUNER** button repeatedly until “**FM**” is highlighted.
2. Select “**Traffic prog.**” to activate (☑) or deactivate (☐) the function.  
When the traffic programme is switched on, the abbreviation TP (**Traffic Programme**) is displayed in the bottom line and you hear the traffic messages regardless of the audio source that is currently active.

### Setting the Traffic prog. volume

The traffic programme volume refers to the volume at which the traffic programme announcements are output.

It specifies the minimum volume as a function of the volume of the audio source currently selected.

1. Press the **SOUND** button.
2. Press the **OPTION** button or touch the tab of the same name in the header.
3. Select “**Traffic prog.**”.
4. Make the setting you want on the scale by touching the two symbols  and .

## Making settings for radio mode

### Switching RDS on/off

The PCM is capable of receiving RDS signals (RDS = Radio Data System) in FM mode. It supports the following functions:

- station name,
- programme type (PTY),
- traffic programme,
- radio text as well as
- detection of alternative frequencies.  
(Radio stations transmit programmes with the same programme content on different frequencies in different regions.)

You can switch tracking of these alternative frequencies on or off in the Set menu.

1. Press the **TUNER** button repeatedly until “**FM**” is highlighted.
2. Press the **OPTION** button or touch the tab of the same name in the header.
3. Select “**SET FM**”.
4. Select “**RDS**” to activate () or deactivate () the function.

### Switching regionalisation on/off

When RDS (tracking of the alternative frequencies) is active, regionalisation can additionally be switched on or off.

If stations have a station chain with varying regional programme contents, switching on regionalisation prevents switching between the different stations.

1. Press the **TUNER** button repeatedly until “**FM**” is highlighted.
2. Press the **OPTION** button or touch the tab of the same name in the header.
3. Select “**SET FM**”.
4. Select “**Regional**” to activate () or deactivate () the function.

### Switching RDS radio text on/off

1. Press the **TUNER** button repeatedly until “**FM**” is highlighted.
2. Press the **OPTION** button or touch the tab of the same name in the header.
3. Select “**SET FM**”.
4. Select “**Radio text**” to activate () or deactivate () the function.

### Choosing a PTY (programme type) filter

RDS stations can broadcast the station's programme type (PTY).

The programme type allows stations to be classified based on their genre, for example “pop”, “rock” or “news”.

If a programme type is selected, only stations that correspond to the selected programme type are displayed in the FM station list.

You can select as many different programme types in a list as you wish.

1. Press the **TUNER** button repeatedly until “**FM**” is highlighted.
2. Press the **OPTION** button or touch the tab of the same name in the header.
3. Select “**SET FM**”  
> “**PTY filter**”.
4. Select the programme types you want for sorting () or deselect those you wish to omit () .  
By selecting “**Activate all**” you can select () or deselect () all the programme types in the list.

## Setting sorting criteria for the FM station list

The FM station list can be sorted according to various criteria. You can set the sorting as follows:

1. Press the **TUNER** button repeatedly until "FM" is highlighted.
2. Press the **OPTION** button or touch the tab of the same name in the header.
3. Select "**SET FM**".
4. Select "**Sorting criteria**".  
Various radio buttons are then available for you to select:
  - **Alphabetical**: The station list is sorted alphabetically.
  - **Genre (PTY)**: The station list is sorted according to programme type (PTY).  
If a programme type is selected, only stations that correspond to the selected programme type are displayed in the FM station list. Only after selecting "**Activate all**" in the PTY filter list are all stations that can be received listed.
  - **Station strength**: The station list is displayed sorted according to station strength. Stations with good reception are shown at the top of the list.
  - **Last stations**: The station list shows the stations listened to for at least two minutes. The last station listened to is shown at the top of the list.
  - **Frequency**: The station list is displayed sorted according to the order of the stations in the frequency band.
5. Set the sorting option you want by selecting it.

## TV

The standard TV on the PCM can receive non-encrypted terrestrial analogue and digital (DVB-T) programmes. Depending on the country and reception area, only analogue, digital or a mixture of analogue and digital programmes may be available. If a programme is simultaneously received in both analogue and digital forms, the TV tuner automatically selects the higher-quality of the two. In some areas, DVB-T programmes are also broadcast without picture content. These are characterised by an additional note symbol.

**i** The activation of the automatic hatchback as well as some other vehicle functions may sporadic cause temporary restrictions of the TV reception.

### **WARNING**

**Accident hazard. For your own safety, no TV picture or video text can be shown during driving for legal reasons.**

- ▷ To receive a TV picture, the vehicle must be stopped.
- ▷ In some countries, the parking brake must also be engaged.



### Calling up the main menu for TV mode

- ▷ Press the **TUNER** button repeatedly until the “TV” mode is highlighted in the bottom line. To use TV mode, you must first tune to a TV station. You can do this via a station search or using the TV menu.

**i** You can return from the TV picture of the current station to the main menu for TV mode at any time by touching the display or pressing the Back button .

## Tuning to TV stations

### Displaying the TV picture

1. Press the **TUNER** button repeatedly until the “TV” mode is highlighted in the bottom line.
2. Touch the information area in the TV menu (above the station buttons on the display). The TV picture of the TV station currently tuned to is shown.

### Tuning to stations using the station buttons

Station buttons must already have TV stations stored before they can be used to tune to a station. To find out more, please refer to the section „STORING TV STATIONS“ on page 25.

1. Press the **TUNER** button repeatedly until the “TV” mode is highlighted in the bottom line.
2. Briefly press the station button. The station is tuned to and its TV picture displayed. An information window appears for about 3 seconds.



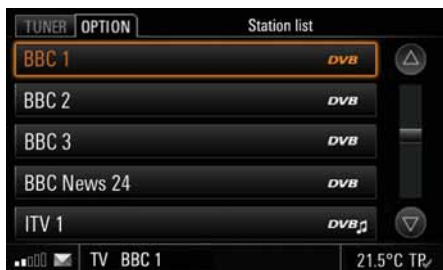

### Tuning to stations using the station list

The station list provides details of the stations that can currently be received.

Depending on the setting, the station list is arranged alphabetically, based on reception quality or based on the last stations. To find out more, please refer to the section „MAKING SETTINGS FOR TV MODE“ on page 27.

1. Press the **TUNER** button repeatedly until the **“TV”** mode is highlighted in the bottom line.
2. Select **“Station list”**.
3. Select the TV station or the DVB-T radio station you want.  
The station is tuned to and its TV picture displayed.

**i** The digital programmes can also be selected using the EPG list.

To find out more, please refer to the section „ELECTRONIC PROGRAMME GUIDE“ on page 27.

### Storing TV stations

Each of the preset memories, **TV 1**, **TV 2**, **TV 3** and **MIXED**, has six memory locations available.

In contrast to all other preset memories, the **MIXED** preset memory can store stations from different modes. Here, you can manually store stations from FM/AM mode as well as stations from TV mode.

### Storing stations manually

1. Press the **TUNER** button repeatedly until the **“TV”** mode is highlighted in the bottom line.
2. Tune to a TV station (> page 24).
3. Press and hold the station button for a few seconds.  
As soon as the TV station is stored on the station button, the station name is shown on the button.

### Storing via an automatic station search

The automatic station search is only available for the preset memories **TV 1**, **TV 2** and **TV 3**.

1. Set **“TV”** mode.
2. If necessary, set the preset memory as follows:
  - a. Press the **OPTION** button or touch the tab of the same name in the header.
  - b. Select **“Preset memory”**.  
The available preset memories are listed.
  - c. Select the preset memory you want.
  - d. Touch the **TUNER** tab in the header again.
- i** You can likewise change the preset memory by touching **“TV 1”**, etc. in the TV main menu.
3. The set preset memory now appears after the **“Autostore”** menu item.  
Select the menu item.  
The search starts. It stores the six programmes with the strongest reception and switches to the strongest programme.



### Showing the information window

- ▷ Press the right rotary knob while in TV mode.

The information window is called up together with the **“Station list”** menu item.

While for digital programmes it shows details about the programme currently active, for analogue programmes the information window only contains the name of the station plus the current time.

**i** The various information can, however, only be displayed if the relevant signal is being broadcast by the station.



### Video text

#### Calling up video text

1. Press the **TUNER** button repeatedly until the **“TV”** mode is highlighted in the bottom line.
2. Press the **OPTION** button or touch the tab of the same name in the header.
3. Select **“Video text”**.  
The video text display appears. When called up for the first time, the programme page “100” is shown.

**i** Not all stations transmit a video text signal.

### Selecting a video text page

1. Touching the display opens a bar for entering the numbers directly.
2. Touch the appropriate digits on the display. After the third digit is entered, the video text search begins and the video text page is shown. The bar for entering numbers is hidden.

**i** If the **“Video text via TV”** function is activated, the video text picture is overlaid onto that of the TV programme. To find out more, please refer to the section **„PLACING VIDEO TEXT OVER THE TV PICTURE“** on page 26.

### Zooming into a video text page

- ▷ Call up an enlarged view of the upper half of the display by turning the right rotary knob . Turn the knob again to switch to an enlarged view of the lower half of the display.
- ▷ Turn once more to return to the normal page view.

### Placing video text over the TV picture

If you activate this function, the video text page is overlaid transparently over the picture of the current TV programme.

1. Press the **TUNER** button repeatedly until the **“TV”** mode is highlighted in the bottom line.
2. Press the **OPTION** button or touch the tab of the same name in the header.
3. Select **“SET TV”**.
4. Select **“Video text via TV”** to activate  or deactivate  the function.

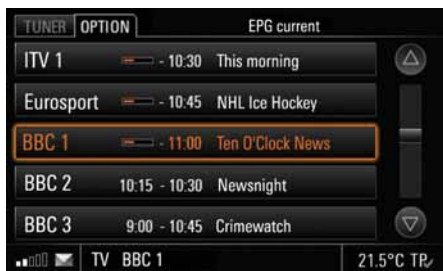

## Electronic Programme Guide

The PCM features an Electronic Programme Guide, which contains various information about the digital programmes. The programmes are listed in chronological order.

Information (station, progress bar, end time and name of current programme) about programmes that are currently playing is shown at the top of the list. This is followed by information (station, start/end time, names of following episodes) for the subsequent programmes.

Please note that **only digital channels** transmit EPG data. This service is not available for analogue channels.

1. Press the **TUNER** button repeatedly until the “TV” mode is highlighted in the bottom line.
2. Press the **OPTION** button or touch the tab of the same name in the header.
3. Select “EPG list”.

The Electronic Programme Guide appears. Selecting an entry in the **EPG list** tunes to the corresponding programme and shows its TV picture.

**i** The menu item is greyed out if no EPG data is being received.

You can also view the EPG data available for the current programme in the **INFO** menu by selecting the “Details TV” menu item. To find out more, please refer to the section „DISPLAYING DETAILED INFORMATION ABOUT THE ACTIVE AUDIO SOURCE“ on page 98.

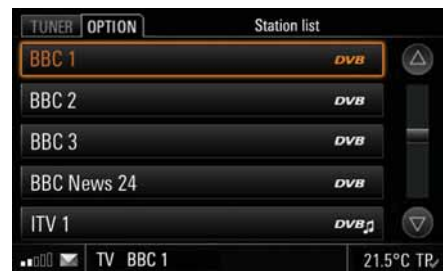

## Making settings for TV mode

### Setting sorting of the station list

The TV station list can be sorted according to various criteria. You can set the sorting as follows:

- **Alphabetical:** When sorted alphabetically, DVB-T TV stations are shown first, followed by analogue TV stations. DVB-T radio stations are at the bottom of the list.
- **Station strength:** When sorted based on station strength, the stations are listed in descending order of reception quality.
- **Last stations:** The station list shows the stations tuned to for at least two minutes. Stations that cannot be received are not displayed.

1. Press the **TUNER** button repeatedly until the “**TV**” mode is highlighted in the bottom line.
2. Press the **OPTION** button or touch the tab of the same name in the header.
3. Select “**SET TV**”  
> “**Sorting criteria**”.
4. Select the sorting you want.

### Setting the reception country

Information about the available channel range is stored for the PCM in the country setting.

If you take your vehicle abroad and wish to use the TV tuner, you should first set the correct entry in the country list.

1. Press the **TUNER** button repeatedly until the “**TV**” mode is highlighted in the bottom line.
2. Press the **OPTION** button or touch the tab of the same name in the header.
3. Select “**SET TV**”  
> “**Reception country**”.

The country list is opened. It is sorted alphabetically. If the correct region is not available in the list, you can choose a setting with a symbol representing the correct TV standard.

**i** A complete list of the reception countries can be found in the section „**AFFILIATED COUNTRIES FOR TV TUNER COUNTRY SETTINGS**“ on page 182.



### Setting TV picture parameters

#### Setting the Brightness

1. Press the **TUNER** button repeatedly until the “**TV**” mode is highlighted in the bottom line.
2. Press the **OPTION** button or touch the tab of the same name in the header.
3. Select “**SET TV**”  
> “**Picture param. - TV**”  
> “**Brightness**”.
4. Make the setting you want by touching the two symbols ▲ and ▼.

#### Setting the Contrast

1. Press the **TUNER** button repeatedly until the “**TV**” mode is highlighted in the bottom line.
2. Press the **OPTION** button or touch the tab of the same name in the header.
3. Select “**SET TV**”  
> “**Picture param. - TV**”  
> “**Contrast**”.
4. Make the setting you want by touching the two symbols ▲ and ▼.

### Setting the Colour

1. Press the **TUNER** button repeatedly until the “**TV**” mode is highlighted in the bottom line.
2. Press the **OPTION** button or touch the tab of the same name in the header.
3. Select “**SET TV**”  
> “**Picture param. - TV**”  
> “**Colour**”.
4. Make the setting you want by touching the two symbols ▲ and ▼.

## Setting the Format

1. Press the **TUNER** button repeatedly until the “**TV**” mode is highlighted in the bottom line.
2. Press the **OPTION** button or touch the tab of the same name in the header.
3. Select “**SET TV**”  
> “**Picture param. - TV**”  
> “**Format**”.

The following options are then available for you to select:

– “**Automatic**”

The picture format being received by the TV tuner is evaluated and its on-screen display is adjusted accordingly (automatic format switching between 4:3 and 16:9).

– “**4:3**”

The picture is shown in such a way that no image contents are lost.

– “**16:9**”



The picture is expanded to cover the entire width of the display. The picture is cropped at the upper and lower edges of the display. This setting is particularly useful for programmes that are broadcast with a black border at the upper and lower edges of the display.

4. Select the setting you want.

**i** With the **Automatic** setting, an ID broadcast by the station in question is analysed. Some stations do not broadcast this ID correctly, with the result that the PCM cannot implement format settings automatically. Under certain circumstances, poor reception can lead to the ID not being analysed properly. In such cases, please set a fixed format (4:3 or 16:9).

## Setting the tint (special feature of NTSC stations)

The **Tint** display option is additionally available when receiving signals from NTSC stations (**N**ational **T**elevision **S**ystem **C**ommittee: colour TV standard in the USA and Japan, amongst other countries). This allows colour distortions related to transmission to be corrected.

1. Press the **TUNER** button repeatedly until the “**TV**” mode is highlighted in the bottom line.
2. Press the **OPTION** button or touch the tab of the same name in the header.
3. Select “**SET TV**”  
> “**Picture param. - TV**”  
> “**Tint**”.
4. Make the setting you want by touching the two symbols  and .

# MEDIA

CD audio/DVD-Audio/DVD-Video .....	31	USB .....	40
Loading and ejecting CDs/DVDs .....	33	Calling up the main menu for	
Calling up the main menu for		USB mode .....	41
CD/DVD mode .....	34	Searching for a track .....	41
Selecting a CD/DVD .....	34	Track list .....	42
Selecting a track .....	34	Skipping to the previous/next track .....	43
Selecting a track (MP3 CD/DVD).....	34	Fast forward/reverse .....	43
Selecting a chapter in video DVD .....	34	Repeating a track .....	43
Setting the audio format for video DVD .....	35	Switching the shuffle function on/off .....	43
Setting audio groups (DVD-Audio) .....	35	Starting/stopping scanning .....	43
Naming a CD .....	35	External audio source.....	44
Skipping to the previous/next track .....	35	Calling up an external audio source.....	44
Fast forward/reverse.....	35	Activating the interface .....	44
Repeating a track .....	35	Adapting the volume for an	
Switching the shuffle function on/off .....	35	external audio source .....	44
Starting/stopping scanning .....	35	External Bluetooth® audio source.....	45
Searching for music in MP3 mode		Calling up an external Bluetooth®	
(full text search) .....	36	audio source/starting playback .....	45
iPod.....	37	Activating the interface .....	45
Calling up the main menu for iPod mode .....	37	Skipping a track .....	46
Searching for music .....	37	Fast forward/reverse .....	46
Playlists .....	38	Repeating a track .....	46
Track list .....	38	Switching the shuffle function on/off .....	46
Skipping to the previous/next track .....	39	Starting/stopping scanning .....	46
Fast forward/reverse.....	39	Bluetooth® settings .....	46
Repeating a track .....	39	Calling up Bluetooth® settings.....	46
Switching the shuffle function on/off .....	39	Switching Bluetooth® on/off.....	46
Adapting the volume for iPod mode .....	39	Adding a new Bluetooth® device.....	46
		Establishing a connection from an	
		external Bluetooth® device.....	47
		Setting visibility .....	47
		Authorised Bluetooth® devices .....	47

## CD audio/DVD-Audio/DVD-Video

### NOTICE

- ▷ Only use standard round CDs and standard DVDs with a diameter of 12 cm.
- ▷ Always touch the CD/DVD at the edges only. Never touch the side without writing and keep the CD/DVD clean.
- ▷ Never stick anything on the CD/DVD.
- ▷ Protect the CD/DVD against direct sunlight and from heat sources such as heaters, etc.
- ▷ Before playing the CD/DVD, it should be cleaned with a special, commercially available cleaning cloth, wiping from the centre outwards. Solvents such as petrol, thinners or other commercially available cleaning agents and anti-static sprays must not be used.
- ▷ Do not bend the CD/DVD.

The system may **not be able to play** copy-protected CDs/DVDs or CDs with CD-ROM sections that **do not correspond to the audio CD standard**.

---

### Notes on copyright

You are only permitted to create copies of CDs/DVDs for your own private use. The copyright exceptions do not cover circulation of the duplicated CDs/DVDs to third parties.

The music tracks that you can create for and play in MP3 mode are generally copyright-protected under the applicable international and national laws. In many countries, the reproduction of copyrighted material is not permitted, even if only for personal use, without the express prior consent of the copyright holder. Please check the current copyright laws for your country and comply with them. These restrictions do not apply, for example, to your own compositions and recordings or to recordings for which authorisation has been obtained from the copyright holder.

**The most current laws always apply!**

### Notes on the media supported

To avoid problems when playing your CDs/DVDs, please note the following:

- Permissible media:
  - CD-R and CD-RW (650 MB and 700 MB)
  - DVD+R and DVD+RW
  - DVD-R and DVD-RW
- Permissible file systems:
  - CD-ROM (Yellow Book)/ISO 9660 Level 1/Joliet for CD (filenames max. 64 characters)
- Permissible file structures:
  - The maximum number of tracks per disc is 4,000.
  - A disc may hold a maximum of 2,000 folders in total.
  - Each folder in turn may contain a maximum of 1,000 tracks.
  - The maximum directory depth is 11 levels.

**No** warranty is accepted for:







- poor quality user-burned CDs/DVDs,
- CDs of other formats,
- Mixed Mode CDs,
- CD-Extra CDs as well as
- multi-session CDs/DVDs.

CDs/DVDs that have not been finalised cannot be played.

Insertion of a non-standard CD/DVD format such as DVD-Plus (one side audio CD, the other side DVD) may lead to **irreparable damage of the drive** due to the greater thickness of the media.

### Supported audio formats

The PCM supports the following audio formats:

	MP3 * (MPEG1 Audio Layer 3)
	WMA * (Windows Media Audio)
	AAC-LC *(Low Complexity Advanced Audio Coding)
	WAVE file format *
	DTS ** (Digital Theater Systems)
	Dolby® Digital ***
	Meridian Lossless Packing ****

\*) No guarantee can be made that all MP3, WMA, AAC and WAV formats can be played back, due to the wide variety of different audio programmes (encoders) available.

\*\*) Manufactured under licence in accordance with US patents No. 5.451.942, 5.956.674, 5.974.380, 5.978.762, 6.487.535 and other patents issued and registered in the USA and internationally. DTS and DTS Digital Surround are registered trademarks and the DTS logos and the DTS symbol are trademarks of DTS, Inc. © 1996-2008 DTS, Inc. All rights reserved.

\*\*\*) Dolby and the Double-D symbol are trademarks of Dolby Laboratories.

\*\*\*\*) MLP Lossless™ is a trademark of Dolby Laboratories.

### Notes on DVD mode

Video DVDs generally feature a regional code. Information on this can usually be found either on the DVD itself or on the DVD sleeve.

The CD/DVD drive of the PCM detects the respective regional code of the video DVD inserted. As per the “Regional Protection Code”, it allows you to change the regional code up to five times. Please contact your Porsche partner to find out how to change the regional code.

You will find a list of regional codes in the section „REGIONAL CODES FOR VIDEO DVDS“ on page 182.

When playing video DVDs, only playback of the audio information is supported.

Some of the video DVDs you find in stores may not conform to the standards. You may experience sound or other playback problems with these DVDs.

Discs, DVD authoring software, burning software and burners are widely available. Due to this wide variety, we cannot guarantee that the CD/DVD drive of the PCM will be able to play every user-burned video DVD.





## Loading and ejecting CDs/DVDs

### Loading a disc in a PCM with CD/DVD drive

- ▷ Insert the disc into the CD/DVD slot with the printed side facing **upwards**.  
Incorrectly inserted CDs/DVDs will not be played.

### Ejecting a disc in a PCM with CD/DVD drive

- ▷ Briefly press the  button.  
The CD/DVD is stopped and ejected.

The system automatically switches to the current audio source in TUNER mode as soon as you have removed the CD/DVD from the magazine compartment.

### Calling up the CD/DVD changer menu

- ▷ Briefly press the  button.  
The CD/DVD changer menu is displayed. A button is displayed for each compartment in the changer magazine.

If there is a CD or DVD in the compartment, you will see the title of the CD/DVD on the button (if available).

If the title of the CD/DVD is not available, the format of the disc (CD or DVD) is indicated instead.

If a compartment is empty, “empty” is shown beside the compartment number on the display.

### Loading a disc in a PCM with CD/DVD changer

1. Briefly press the  button.  
The CD/DVD changer menu is displayed.
2. Select an empty magazine compartment.  
You are then prompted to insert a disc.
3. Push the CD/DVD into the slot.  
The printed side of the CD/DVD must face **upwards**.  
Incorrectly inserted CDs/DVDs will not be played. To allow for the fastest possible changes, you should load the magazine successively beginning with compartment 1.

“DISC” flashes on the button. As soon as the CD/DVD is detected, it is scanned and the current track is shown on the display.

### Loading all discs in a PCM with empty CD/DVD changer

- ▷ Press and hold the  button or any magazine compartment for several seconds.  
All magazine compartments are moved into position one after the other and at each stage you are prompted to insert a CD/DVD.

### Ejecting a disc in a PCM with CD/DVD changer

1. Briefly press the  button.  
The CD/DVD changer menu is displayed.
2. Select the magazine compartment you want.  
The CD/DVD is stopped if necessary and ejected.
3. Remove the CD/DVD.  
If you do not insert another CD/DVD in this magazine compartment, the CD/DVD in the next occupied compartment is played.

**i** If you do not remove the CD/DVD from the slot, the PCM will automatically retract it after a short while.

### Ejecting all discs in a PCM with CD/DVD changer

- ▷ Press and hold the  button or any magazine compartment for several seconds.  
All discs are ejected in sequence.

The system automatically switches to the current audio source in TUNER mode as soon as you have removed the last CD/DVD from the magazine compartment.

## Calling up the main menu for CD/DVD mode

- ▷ Press the **MEDIA** button repeatedly until the “**DISC**” audio source is highlighted in the bottom line.

## Selecting a CD/DVD

1. Press the **MEDIA** button repeatedly until the “**DISC**” audio source is highlighted in the bottom line.
2. Select “**Disc selection**”.  
A list of the available CDs/DVDs is opened.
3. Select the CD/DVD you want.  
Playback is started at the beginning of the disc.

## Selecting a track





You can select a track directly using the track list. The track list shows the track numbers and, if available, the track names.

1. Press the **MEDIA** button repeatedly until the “**DISC**” audio source is highlighted in the bottom line.
2. Select “**Track list**”.
3. Select the track you want.

## Selecting a track (MP3 CD/DVD)

If the disc currently playing is an MP3 CD/DVD, the track list shows the names of the root directories as well as the subdirectories.

The following symbols are used in the track list to make it easier for you to navigate within the directory structure of the MP3 CD/DVD:

- Subdirectory  Selecting this list entry opens the corresponding subdirectory and displays the directories and tracks it contains.
  - Higher-level directory  Selecting this list entry or pressing the  button displays the higher-level directory.
  - Playlist  Selecting this list entry allows you to play lists of tracks in m3u format you have created on your computer and burned to the CD/DVD.
1. Press the **MEDIA** button repeatedly until the “**DISC**” audio source is highlighted in the bottom line.
  2. Select “**Track list**”.
  3. Select the directory or playlist you want.
  4. Select the track you want.

**i** If the directory structure of the folders is very deep or the number of files is very large, it may not be possible to display all the folders or tracks.

File formats that cannot be played will not be displayed.

To find out more, please refer also to the section „NOTES ON THE MEDIA SUPPORTED“ on page 31.

## Selecting a chapter in video DVD mode

When playing video DVDs, only playback of the audio information is supported.

1. Press the **MEDIA** button repeatedly until the “**DISC**” audio source is highlighted in the bottom line.
2. Select “**Track list**”.
3. Select the chapter you want.

- or if you want to choose a chapter in another film title -

3. Select the first list entry with the “higher-level directory” symbol .  
The list of video titles is opened.
4. Select the video title you want.
5. Select the chapter you want.

## Setting the audio format for video DVD

1. Press the **MEDIA** button repeatedly until the “**DISC**” audio source is highlighted in the bottom line.
2. Press the **OPTION** button or touch the tab of the same name in the header.
3. Select “**DVD audio format**”.  
A list of the available audio formats is opened.
4. Select the audio format you want.

**i** After selecting a new audio format from the list, playback is resumed at the same point in the current chapter if possible. If this is not possible, the current chapter is played once again from the beginning.  
All following tracks are also played with the newly set audio format. If this is not possible with a track, playback reverts to the originally set audio format. This format is then retained for the subsequent tracks.

## Setting audio groups (DVD-Audio)

1. Press the **MEDIA** button repeatedly until the “**DISC**” audio source is highlighted in the bottom line.
2. Select “**Track list**”.
3. Select the first list entry with the “higher-level directory” symbol .  
The list of audio groups is opened.
4. Select the audio group you want.
5. Select the track you want within the audio group.

## Naming a CD

**i** This function is only available for audio CDs and DTS-CDs without CD text.

A maximum of 100 CDs can be named.

1. Press the **MEDIA** button repeatedly until the “**DISC**” audio source is highlighted in the bottom line.
2. Press the **OPTION** button or touch the tab of the same name in the header.
3. Select “**Name CD**”.  
The input menu is opened.
4. Enter the name you want for the CD.

## Skipping to the previous/next track

If the current track has been playing for longer than 10 seconds, pressing the **◀** button resumes playback from the start of the current track.

If the current track has not yet been playing for 10 seconds, playback is resumed from the start of the previous track.

- ▶ If you want to skip to the next track when a CD/DVD is playing, briefly press the **▶** button.
- ▶ If you want to skip back to the start of the track when a CD/DVD is playing, briefly press the **◀** button.

## Fast forward/reverse

- ▶ Press and hold the **▶** button or **◀** button for a few seconds when a CD/DVD is playing until the position you want is reached.

## Repeating a track

Activating this function repeats the current track or chapter (video DVD mode).

- ▶ Select “**Repeat**” while a CD/DVD is playing to activate () or deactivate () the function.
- or to switch it off -
- ▶ Press the **◀** or **▶** button.

## Switching the shuffle function on/off

When you activate this function, the current track is played to the end. The current CD/DVD is then played in random order.

- ▶ Select “**Shuffle**” while a CD/DVD is playing to activate () or deactivate () the function.

## Starting/stopping scanning

When this function is activated, each track on the CD/DVD or each chapter on a video DVD is played for approx. 10 seconds.

1. Press the **MEDIA** button repeatedly until the “**DISC**” audio source is highlighted in the bottom line.
2. Select “**Start scan**” to activate the function.
3. Select “**Stop scan**” to deactivate the function.  
The CD/DVD track that has started playing will continue to play.

The function is automatically stopped as soon as a track is selected directly in the track list.

## Searching for music in MP3 mode (full text search)

The music search in MP3 mode is based on a full text search of the file names.

1. Press the **MEDIA** button repeatedly until the “**DISC**” audio source is highlighted in the bottom line.
2. Press the **OPTION** button or touch the tab of the same name in the header.
3. Select “**Full text search**”.  
The input menu is opened.  
 The menu item is only available when the track list is available.
4. Enter at least three letters of the search term.
5. Call up the search results by selecting “**List**”.
6. Select the track you want in the result list.  
The track is played.



USB jack (Panamera)

## iPod\*

You can connect one of the following iPod models with your PCM via a USB port in the centre console of your vehicle:

- iPod 5th generation/iPod Video (firmware 1.3 or higher),
- iPod nano (1st generation only, firmware 1.3.1 or higher),
- iPod classic,
- iPod touch,
- iPhone,
- later iPod models\*\*.

The connection is established using the USB cable supplied with the iPod.

\*) iPod is a trademark of Apple Computer, Inc. and is registered in the USA and in other countries.

\*\*) The operation of newer iPod models with the PCM **cannot** be guaranteed.



USB jack (Cayenne)

- i** If you encounter any problems it may be necessary to update your iPod's firmware.
- i** Some iPod firmware versions may cause the PCM to malfunction. In this case the iPod must be reconnected.
- i** It is recommended not to leave an iPod in the vehicle for long periods of time as extreme ambient conditions (temperature, humidity) can occur in vehicles. The iPod is charged during use.



USB jack (sports cars)

## Calling up the main menu for iPod mode

- ▷ Press the **MEDIA** button repeatedly until the "iPod" audio source is highlighted in the bottom line.
- i** The "iPod" mode is only displayed if a corresponding device is connected to the interface.

## Searching for music

You can search for specific tracks on your iPod. The following categories are available to you for this:

### - Artists

Displays a list of all available artists. If you select an artist from the list, the number of tracks and albums available for the subsequent search is updated and displayed after the menu item.

## – Albums

Displays a list of the available albums. If you have already selected an artist, only albums by that artist will be available for the subsequent search.

If you select an album from the list, the number of tracks available for the subsequent search is updated.

## – Track

Displays a list of all tracks stored on the iPod. If you have already selected a category (e.g. “Artists”), the list of tracks will have been automatically updated and only tracks by that artist will be available.

## – Music genres

The tracks stored on the iPod are generally assigned to a music genre (provided the “Genre” ID3 tag has been assigned). These music genres can also be used as categories for a search.

If you have selected a music genre, the artists, albums and tracks available for the subsequent search are updated.

Once you select a category, higher-level categories are no longer available. After you select an artist, for example, the “**Music genres**” category can no longer be selected.

Selecting “**Start playback**” ends the search and plays the tracks in accordance with your previous selection.

Below is an example of how to perform a search for the tracks of a specific artist and album.

1. Press the **MEDIA** button repeatedly until the “iPod” audio source is highlighted in the bottom line.
2. Select “**Find music**” in iPod mode.
3. Select “**Artists**”.

A list of all the artists whose tracks are stored on the iPod is opened.

4. Select the artist you want in the list.
5. Select “**Albums**”.

A list of all the albums by the selected artist stored on the iPod is opened.

6. Select the album you want in the list.  
The number of tracks on this album is now shown in brackets on the “**Track**” button.
7. Select “**Start playback**”.

The tracks on the selected album are now played one after the other.

- i** The tracks from a music search are displayed in the track list. To find out more, please refer also to the section „TRACK LIST“ on page 38. The iPod determines the sorting of the lists.

## Playlists

Selecting this list entry allows you to play lists of tracks you have stored on your iPod.

1. Press the **MEDIA** button repeatedly until the “iPod” audio source is highlighted in the bottom line.
2. Select “**Playlists**”.  
The menu is opened.
3. Select the playlist you want.  
The tracks in the list are played one after the other. After the last track is played, the playlist is automatically repeated.

## Track list

If you have performed a music search or selected a playlist, the corresponding tracks are displayed in the track list.

- i** The iPod determines the sorting of the lists.
1. Press the **MEDIA** button repeatedly until the “iPod” audio source is highlighted in the bottom line.
  2. Select “**Track list**”.  
The menu is opened.
  3. Select the track you want.  
The track is played.

### Skipping to the previous/next track

- ▷ If you want to skip to the next track when the iPod is playing, briefly press the **▷** button.
- ▷ If you want to skip back to the start of the track when the iPod is playing, briefly press the **◀** button.

### Fast forward/reverse

- ▷ Press the **▷** button or **◀** button when the iPod is playing until the position you want is reached.

### Repeating a track

Activating this function repeats the current track.

- ▷ Select "**Repeat**" when the iPod is playing to activate () or deactivate () the function.
- **or** to switch it off -
- ▷ Press the **◀** or **▷** button.

### Switching the shuffle function on/off

When you activate this function, the current track in the music selection is played to the end. All tracks in the current music selection are then played in random order.

- ▷ Select "**Shuffle**" when the iPod is playing to activate () or deactivate () the function.

**i** The sorting of the lists is determined by the iPod.

### Adapting the volume for iPod mode

**i** You will only be able to access the "**SET MEDIA / AUX**" menu if there is at least one audio source from the DISC area available.

1. Press the **MEDIA** button.
2. Press the **OPTION** button or touch the tab of the same name in the header.
3. Select "**SET MEDIA / AUX**"
  - > "**Volume adaptation**"
  - > "**Volume iPod**".
4. Make the setting you want by selecting the symbols **▲** and **▼** or by turning **⌚** the right rotary knob.



USB jack (Panamera)



USB jack (Cayenne)



USB jack (sports cars)

## USB

You can connect a USB memory stick or a USB MP3 player containing audio files to the USB interface of the PCM in the centre console.

You can use it to:

- play audio data from your USB stick (permitted formats: MP3, WAV, WMA and AAC-LC),
- download data from the Sport display as well as
- download data from the PCM logbook.

- i** You cannot connect USB devices that require the installation of special drivers.
- i** The use of a USB hub is not permitted.
- i** Compatibility with all memory sticks and MP3 players **cannot** be guaranteed due to the rapid rate at which USB media are developing.
- i** USB devices with increased power requirements (e.g. external hard drives) cannot be operated on the USB interface in some circumstances.
- i** It is recommended not to leave USB devices in the vehicle for long periods of time as extreme ambient conditions (temperature, humidity) can occur in vehicles.

## Notes on the media supported

To avoid problems when playing your USB devices, please note the following:

- Permissible media:
  - USB mass storage device,
  - USB MP3 player (to MTP standard)
- Permissible file systems:
  - USB devices with the file systems FAT 16 and FAT 32 are supported.
- Permissible USB standards:
  - USB devices that meet the USB 2.0 specifications are supported.
- Permissible file structures:
  - Up to 10,000 tracks are supported on the USB device.



## Calling up the main menu for USB mode

▷ Press the **MEDIA** button repeatedly until the “USB” audio source is highlighted in the bottom line.

**i** The “USB” mode is only displayed if a corresponding device is connected to the interface.

**i** The first time USB mode is activated, the audio files in the USB memory are loaded. The menu cannot be used and the menu items are greyed out during this process. Playback begins as soon as the first tracks are found on the USB device.

## Searching for a track

You can search for specific tracks on your USB device. The following options are available to you for this:

- search for tracks using categories (“**Find music**”),
- search for similar tracks to the track currently playing using categories (“**Play more from**”)

and

- search for tracks using a “**Full text search**”.

**i** The music search only works if metadata for the tracks (ID3 tags) is available.

A database is created in the PCM for the music search. This can take a few minutes.

The tracks from a music search are compiled in a playlist named “**Tracks from music search**” under the “**Track list**” menu item.

## Searching for tracks by category

You can compile the tracks you want using the following categories:

### – **Artist**

Displays a list of all artists. If you select an artist from the list, the number of tracks available for the subsequent search is updated.

If you select “**All artists**” you can also search using the input menu.

### – **Album**

Displays a list of the available albums. If you have already selected a category (e.g. “Artists”), only albums by that artist will be available for the subsequent search.

If you select an album from the list, the number of tracks available for the subsequent search is updated.

If you select “**All albums**” you can also search using the input menu.

### – **Track**

Displays a list of all tracks stored on the USB device. If you have already selected a category (e.g. “Artists”), the list of tracks will have been automatically updated and only tracks by that artist will be available.

If you select “**All tracks**” you can also search using the input menu.

### – **Music genres**

The tracks stored on the USB device are generally assigned to a music genre (provided the “Genre” ID3 tag has been assigned). These music genres can also be used as categories for a search.

These categories can be used either individually or in succession for the search. The remaining number of entries is updated.

In contrast to the music search in iPod mode, the categories can be set in any order.

Selecting “**Start playback**” ends the search and plays the tracks in accordance with your previous selection.

Below is an example of how to perform a search for tracks by a specific artist on a specific album.

**1.** Press the **MEDIA** button repeatedly until the “USB” audio source is highlighted in the bottom line.

**2.** Select “**Find music**” in USB mode.

**3.** Select “**Artists**”.

A list of all available artists whose tracks are stored on the USB device is opened. Highlight the artist you want by selecting in the list.

**4.** Select the artist you want in the list.

**5.** Select “**Albums**”.

A list of all albums by the selected artist stored on the USB device is opened.

**6.** Select the album you want in the list.

The number of tracks on this album is now shown in brackets on the “**Track**” button.

**7.** Select “**Start playback**”.

The tracks on the selected album are now played one after the other.

### Searching for similar tracks by category



1. Press the **MEDIA** button repeatedly until the “USB” audio source is highlighted in the bottom line.
2. Press the **OPTION** button or touch the tab of the same name in the header.
3. Select “**Play more from**”.  
You can now choose between the following categories:
  - “**Artist**”,
  - “**Album**” and
  - “**Genre**”.
4. Select the category you want.  
The corresponding tracks are played one after the other.

**i** In some cases, no further tracks may be found for the selected category.

### Searching for tracks using a full text search

The full text search function gives you quick access to specific tracks. It is suitable for the following situations:

- there is no metadata (ID3 tags) on your USB device,
- there are a large number of tracks stored on your USB device and a search using filters would produce very long result lists or
- you do not know the exact name of the track/artist you want.

1. Press the **MEDIA** button repeatedly until the “USB” audio source is highlighted in the bottom line.
2. Press the **OPTION** button or touch the tab of the same name in the header.
3. Select “**Full text search**”.  
The input menu is opened.
4. Enter at least three letters of the search term.
5. Call up the search results by selecting “**List**”.  
In the result list, symbols are used to distinguish between an artist, track or album:
  -  Artist
  -  Album
  -  Track
6. Select the artist/album/track you want in the result list.  
The selection is played.

### Track list

The tracks and playlists stored on the USB device are displayed in alphabetical order in the track list. To find out more about using the track list, please refer to the section „SELECTING A TRACK (MP3 CD/DVD)“ on page 34.

1. Press the **MEDIA** button repeatedly until the “USB” audio source is highlighted in the bottom line.
2. Select “**Track list**”.  
The menu is opened.
3. Select the track you want.  
The track is played.  
- or -  
Select the playlist and then the track you want.  
The track is played.

**i** If the directory structure of the folders is very deep or the number of files is very large, it may not be possible to display all of the folders or tracks.  
File formats that cannot be played will not be displayed.

### Skipping to the previous/next track

If the current track has been playing for longer than 10 seconds, pressing the ◀ button resumes playback from the start of the current track.

If the current track has not yet been playing for 10 seconds, playback is resumed from the start of the previous track.

- ▷ If you want to skip to the next track in USB mode, briefly press the ▶ button.
- ▷ If you want to skip back to the start of the track in USB mode, briefly press the ◀ button.

### Fast forward/reverse

- ▷ Press the ▶ button or ◀ button in USB mode until the position you want is reached.

### Repeating a track

Activating this function repeats the current track.

- ▷ Select “Repeat” in USB mode to activate (☑) or deactivate (☐) the function.
- or to switch it off -
- ▷ Press the ◀ or ▶ button.

### Switching the shuffle function on/off

When you activate this function, the current track is played to the end. All tracks in the current music selection are then played in random order.

- ▷ Select “Shuffle” in USB mode to activate (☑) or deactivate (☐) the function.

The shuffle function is automatically deactivated as soon as a new music search is started.

### Starting/stopping scanning

When this function is activated, each track from the USB device or the current music selection is played for approx. 10 seconds.

1. Press the **MEDIA** button repeatedly until the “USB” audio source is highlighted in the bottom line.
2. Select “Start scan” to activate the function.
3. Select “Stop scan” to deactivate the function. The track on the USB device that has started playing continues to be played.

The function is automatically stopped as soon as a track is selected directly in the track list or a music search is performed.



AUX jack (Panamera)

## External audio source

You can use the AUX interface to connect an external audio source that is operated on the source itself rather than on the PCM. Please refer to the operating manual for the relevant device.

### **⚠ WARNING**

#### **Accident hazard. Distraction could result in you losing control of the vehicle.**

- ▷ Operate the external audio source only when you are safely in control of your vehicle and traffic conditions permit. If in doubt, stop the vehicle and operate the external audio source while the vehicle is parked.



AUX jack (Cayenne)

## Calling up an external audio source

- ▷ Press the **MEDIA** button repeatedly until the “AUX” audio source is highlighted in the bottom line.

## Activating the interface

To be able to select a connected external audio source with the **MEDIA** button, the interface must be activated in the SET menu.

1. Press the **MEDIA** button.
2. Press the **OPTION** button or touch the tab of the same name in the header.
3. Select “**SET MEDIA / AUX**”.  
You will only be able to access the “**SET MEDIA / AUX**” menu if there is at least one CD/DVD inserted or at least one audio source activated (☑) in the menu.
4. Select “**AUX**” to activate (☑) or deactivate (☐) the function.



AUX jack (sports cars)



## Adapting the volume for an external audio source

- i** Volume control should mainly be performed on the external audio source to avoid large differences in volume (particularly increases) when changing the audio source.

Recommendation:

- ▷ Set the maximum volume on the external audio source.
- ▷ Then set the volume you want on the PCM. You can also adapt the volume of the external audio source to the volume of the PCM.

- i** You will only be able to access the “**SET MEDIA / AUX**” menu if there is at least one audio source from the DISC area available.

1. Press the **MEDIA** button.
2. Press the **OPTION** button or touch the tab of the same name in the header.
3. Select **"SET MEDIA / AUX"**
  - > **"Volume adaptation"**
  - > **"Volume AUX"**.
4. Make the setting you want by selecting the symbols  and  or by turning  the right rotary knob.

## External Bluetooth® audio source

You can also connect an external audio source that is partially operated on the source itself rather than on the PCM via a Bluetooth® connection.

**i** For the connection and operation of the external Bluetooth® audio source, the PCM also supports the A2DP/AVRCP profile. The extent to which the external Bluetooth® audio source can be operated on the PCM depends on the functions supported by the audio source. Operation of the external Bluetooth® audio source on the PCM is therefore restricted in some cases. In other cases, operation on the PCM is not possible. The audio source is then operated on the connected device itself. Please refer to the operating manual for the relevant device.

### WARNING

#### Accident hazard. Distraction could result in you losing control of the vehicle.

- ▷ Operate the external Bluetooth® audio source only when you are safely in control of your vehicle and traffic conditions permit. If in doubt, stop the vehicle and operate the external Bluetooth® audio source while the vehicle is parked.

## Calling up an external Bluetooth® audio source/starting playback



- ▷ Press the **MEDIA** button repeatedly until the **"AUX BT"** audio source is highlighted in the bottom line.

Playback starts automatically if this is supported by the Bluetooth® device. It may be necessary to start playback manually on the Bluetooth® device.

**i** The **"AUX BT"** mode is only displayed if a corresponding device is connected to the interface.

### Activating the interface

To use an external Bluetooth® audio source, the AUX Bluetooth function must be activated in the **"SET MEDIA / AUX"** menu.

1. Press the **MEDIA** button.
2. Press the **OPTION** button or touch the tab of the same name in the header.
3. Select **"SET MEDIA / AUX"**.
  - You will only be able to access the **"SET MEDIA / AUX"** menu if there is at least one CD/DVD inserted or at least one audio source activated () in the menu.
4. Select **"AUX Bluetooth"** to activate () or deactivate () the function.
  - When you deactivate **"AUX Bluetooth"**, the Bluetooth® devices are deleted from the list if necessary.

**i** With some devices, it may be necessary to set the volume on the device.

Recommendation:

- ▷ Set the required volume on the external Bluetooth® audio source.
- ▷ Then set the volume you want on the PCM.

**i** The functions and displays depend on the active Bluetooth® device.

### Skipping a track

- ▷ If you want to skip to the next track, briefly press the **▷** button.
- ▷ If you want to skip back to the start of the track/to the previous track, briefly press the **◀** button.

### Fast forward/reverse

- ▷ Press the **▷** button or **◀** button in AUX BT mode until the position you want is reached.

### Repeating a track

Activating this function repeats the current track.

- ▷ Select "**Repeat**" in Bluetooth® AUX mode to activate () or deactivate () the function.
- **or** to switch it off -
- ▷ Press the **◀** or **▷** button.

### Switching the shuffle function on/off

When you activate this function, the current track is played to the end. All tracks are then played in random order.

- ▷ Select "**Shuffle**" in Bluetooth® AUX mode to activate () or deactivate () the function.

### Starting/stopping scanning

When this function is activated, each track from the external audio source is played for approx. 10 seconds.

1. Press the **MEDIA** button repeatedly until the "**AUX BT**" audio source is highlighted in the bottom line.
2. Select "**Start scan**" to activate the function.
3. Select "**Stop scan**" to deactivate the function. The track from the external audio source that has started playing will continue to play.

## Bluetooth® settings

### Calling up Bluetooth® settings

1. Press the **MEDIA** button.
2. Press the **OPTION** button or touch the tab of the same name in the header.
3. Select "**SET MEDIA / AUX**"  
> "**Bluetooth settings**".

**i** You will only be able to access the "**SET MEDIA / AUX**" menu if there is at least one audio source from the DISC area available.

### Switching Bluetooth® on/off

#### Switching Bluetooth® on

- ▷ Select "**Switch on Bluetooth**" in the *Bluetooth®* settings.

#### Switching Bluetooth® off

- ▷ Select "**Switch off Bluetooth**" in the *Bluetooth®* settings.

### Adding a new Bluetooth® device

For the PCM to find your *Bluetooth®* device, please ensure that the *Bluetooth®* function on the device has been activated and set to "visible".

1. Select "**New MP3 player**" in the *Bluetooth®* settings.

A search is started and a list of the devices found is displayed.

2. Choose the device you want by selecting it in the list.

You will be prompted to enter the *Bluetooth*<sup>®</sup> code for your device on the PCM.

**i** This *Bluetooth*<sup>®</sup> code can be preset. In this case the code can be found in the operating manual for your MP3 player.

If the code is freely selectable, enter a 4-digit code of your choice on both sides and confirm it with **“OK”**.

Once you have entered the code, successful authorisation of the device is shown on the display.

### Establishing a connection from an external *Bluetooth*<sup>®</sup> device

To find out more, please refer to the section „ESTABLISHING A CONNECTION FROM AN EXTERNAL BLUETOOTH<sup>®</sup> DEVICE“ on page 62.

### Setting visibility

To find out more, please refer to the section „SETTING VISIBILITY“ on page 63.

### Authorised *Bluetooth*<sup>®</sup> devices

This function allows you to display a list of the *Bluetooth*<sup>®</sup> devices currently authorised to connect with your PCM. The list contains all authorised MP3 players .

### Displaying authorised *Bluetooth*<sup>®</sup> devices

- ▷ Select **“List of MP3 players”** in the *Bluetooth*<sup>®</sup> settings.

### Connecting an authorised *Bluetooth*<sup>®</sup> device with the PCM

1. Select **“List of data devices”** in the *Bluetooth*<sup>®</sup> settings.
2. Select the device you want in the list.
3. Select **“Connect”**.

### Disconnecting an authorised and connected *Bluetooth*<sup>®</sup> device from the PCM

1. Select **“List of data devices”** in the *Bluetooth*<sup>®</sup> settings.
2. Select the device you want in the list.
3. Select **“Disconnect”**.

### Renaming an authorised *Bluetooth*<sup>®</sup> device

1. Select **“List of data devices”** in the *Bluetooth*<sup>®</sup> settings.
2. Select the device you want in the list.
3. Select **“Rename”**.  
The input menu is opened.
4. Enter the name you want and confirm by selecting **“OK”**.  
The name of the device is now changed in the PCM.

### Deleting an authorised *Bluetooth*<sup>®</sup> device from the list

1. Select **“List of data devices”** in the *Bluetooth*<sup>®</sup> settings.
2. Select the device you want in the list.
3. Select **“Delete”**.
4. Confirm the prompt that appears by selecting **“Yes”**.

### Deleting the list of authorised *Bluetooth*<sup>®</sup> devices

1. Select **“List of data devices”** in the *Bluetooth*<sup>®</sup> settings.
2. Select any device in the list.
3. Select **“Delete”**.
4. Select **“Delete list”**.
5. Confirm the prompt that appears by selecting **“Delete all”**.

### Displaying details for the authorised *Bluetooth*<sup>®</sup> device

1. Select **“List of data devices”** in the *Bluetooth*<sup>®</sup> settings.
2. Select any device in the list.
3. Select **“Device details”**.  
The following information is displayed:
  - the device name,
  - the *Bluetooth*<sup>®</sup> address as well as
  - the supported services.

# PHONE

Bluetooth® .....	50	Telephone settings	
Prerequisites for the mobile phone .....	51	(Bluetooth® mobile phone preparation) .....	60
Hands-free quality .....	51	Setting the ringtone type .....	60
Interruptions to the connection		Setting the ringtone volume .....	60
while driving .....	51	Setting the call volume .....	60
Switching Bluetooth® on/off .....	51	Setting the microphone volume .....	60
<b>Operating the</b>		Switching 3-way calling on/off .....	60
<b>Bluetooth® hands-free unit</b>		Bluetooth® settings	
(Bluetooth® mobile phone preparation) .....	52	(Bluetooth® mobile phone preparation) .....	61
Authorising a mobile phone .....	52	Authorised Bluetooth® devices .....	61
Establishing a connection from an		Adding a new Bluetooth® device .....	62
external Bluetooth® device .....	52	Establishing a connection from an	
Conducting calls .....	53	external Bluetooth® device .....	62
Temporarily muting the		Setting visibility .....	63
hands-free microphone .....	53	Phonebook settings	
Accepting a call .....	53	(Bluetooth® mobile phone preparation) .....	63
Ending a call .....	54	Setting the memory for the phonebook .....	63
Rejecting a call .....	54	Setting sorting .....	63
Dialling a number .....	54	Setting automatic transfer of the	
Touch tone dialling (DTMF tones) .....	54	phonebook .....	64
Swapping back and forth between		Transferring the phonebook .....	64
the keypad and call options during a call .....	55	Transferring the phonebook entries	
Using the quick dial (redial) function .....	55	manually .....	64
Using the direct dial function .....	55	Deleting the phonebook .....	64
Holding a call .....	55	<b>Operating the PCM telephone</b> .....	65
Phonebook .....	55	Inserting the SIM card in the PCM .....	65
List of previous calls .....	56	Entering the PIN .....	65
List of received calls .....	57	Conducting calls .....	66
Establishing an additional call .....	58	Temporarily muting the	
Call waiting .....	58	hands-free microphone .....	66
Call waiting (swapping) and conference .....	59	Accepting a call .....	66
Speed dialling .....	59	Ending a call .....	67
		Rejecting a call .....	67
		Dialling a number .....	67
		Touch tone dialling (DTMF tones) .....	67
		Swapping back and forth between	
		the keypad and call options during a call .....	68
		Using the quick dial (redial) function .....	68
		Using the direct dial function .....	68
		Holding a call .....	68
		PCM phonebook .....	69
		List of previous calls .....	70
		List of received calls .....	71
		Establishing an additional call .....	72
		Call waiting .....	73
		Call waiting (swapping) and conference .....	73
		Using supplementary services .....	74
		Making an emergency call .....	74
		Text messages (SMS)	
		(with PCM telephone only) .....	74
		Reading a text message .....	75
		Replying to a text message .....	75
		Creating and sending a new text message .....	76
		Forwarding a text message .....	77
		Deleting a text message .....	78
		Reading a vCard .....	78
		Accepting vCards .....	78
		Editing vCard details .....	78
		Discarding (deleting) vCards .....	79
		Numbers in text messages .....	79
		Displaying the complete text .....	80
		Creating a template .....	80
		Telephone settings	
		(PCM telephone) .....	80
		Switching the PCM telephone on/off .....	80
		Setting ringtones .....	81
		Selecting a network .....	81
		Displaying the IMEI .....	81
		Switching 3-way calling on/off .....	82
		SIM settings .....	82



Call settings		Establishing an additional call .....	90
(PCM telephone) .....	83	Call waiting (swapping) and conference .....	91
Activating call forwarding .....	83	Phonebook.....	91
Switching the “Call waiting” function on/off.....	84	Text messages (SMS).....	92
Switching the “Redial” function on/off.....	84	Settings.....	94
Setting transfer of your own number .....	84		
Setting automatic call answering .....	84		
Bluetooth® settings			
(PCM telephone) .....	85		
Authorised Bluetooth® devices .....	85		
Adding a new Bluetooth® device.....	86		
Setting visibility .....	86		
Finding the cordless handset.....	87		
Phonebook settings .....	87		
Setting the memory for the phonebook .....	87		
Setting sorting .....	87		
Setting automatic transfer of the phonebook .....	88		
Transferring the phonebook .....	88		
Deleting the phonebook .....	88		
Settings for messages and data			
(PCM telephone) .....	88		
Changing the number of the SMS service centre .....	88		
Switching the SMS signal tone on/off.....	88		
Cordless handset.....	89		
Switching the cordless handset on/off .....	89		
Charging the cordless handset .....	89		
General operation.....	89		
Accepting a call.....	89		
Ending a call .....	90		
Rejecting a call.....	90		
Dialling a number .....	90		
Temporarily muting the handset microphone.....	90		

The PCM can be equipped with an integrated car phone (PCM telephone) as an optional accessory. This car phone (PCM telephone) is a quadband GSM radio telephone (GSM 850/900/1800/1900) with hands-free unit and a cordless handset. It conforms to the GSM standard (Global System for Mobile communication) currently implemented in more than 100 countries. For information on the current GSM coverage and planned expansion of the coverage areas of GSM networks, contact your network provider. Your PCM also offers a facility for the connection, operation and hands-free operation of an external telephone (mobile phone) via a *Bluetooth*<sup>®</sup> connection.

An alternative equipment version (*Bluetooth*<sup>®</sup> mobile phone preparation) does not include a PCM telephone, but does still allow you to use the PCM as a hands-free unit for *Bluetooth*<sup>®</sup> mobile phones.

A list of selected compatible mobile telephones is available on the Internet at <http://www.porsche.com>.

 **WARNING**

**Injury hazard. The telephone must not be used near explosives or flammable materials (e.g. at a petrol station) or near operations involving explosives.**

**Mobile phones must be switched off in certain hazardous areas such as near petrol stations, fuel depots, chemical plants and demolition work in progress using explosives, for example. They can interfere with technical equipment.**

- ▷ Please heed appropriate warnings.
- ▷ Observe statutory regulations and local restrictions when using the telephone.

## ***Bluetooth***<sup>®</sup>

*Bluetooth*<sup>®</sup> is a system for establishing radio connections between electronic devices within a maximum range of 10 metres (approx. 33 feet). *Bluetooth*<sup>®</sup> allows you to use your mobile phone via the PCM. You can accept, make and end calls. You use your vehicle's audio system for hands-free operation and have access to the contents of your phonebook.

 Access to the phonebook depends on the range of functions supported by the mobile phone used.

The connection is established in different ways depending on the telephone version in your PCM:

- In the case of a PCM **with *Bluetooth***<sup>®</sup> mobile phone preparation, connection takes place using the **Hands-Free Profile**.

When connecting using the Hands-Free Profile, the PCM simply serves as a ***Bluetooth***<sup>®</sup> **hands-free unit** for the external telephone.

The SIM card of the external telephone cannot be accessed (e.g. to write a text message) and the range of functions is restricted accordingly (depending on the mobile phone used).

- In the case of a PCM **with PCM telephone**, connection takes place using the **SIM Access Profile** if this profile is supported by the mobile phone used. When connecting using the SIM Access Profile, the SIM card of the mobile phone is used for operation of the PCM telephone. The data on the SIM card (phonebook entries and text messages) is read out by the PCM and is available for use on the PCM.

The range of functions for a connection using the SIM Access Profile is largely the same as the function of the PCM telephone with SIM card inserted.

If the mobile phone does not support the SIM Access Profile, connection takes place using the Hands-Free Profile.

With mobile phones that support both profiles, it is possible to switch between the connection types.

**i** The option of connection using the SIM Access Profile is not available on all mobile phones and must also be activated on the device for some mobile phones. In some countries there may be limitations on the use of devices with *Bluetooth*<sup>®</sup>. Please contact the local authorities for further information.

### Prerequisites for the mobile phone

Not all mobile phones are equally suitable for making and receiving calls via the *Bluetooth*<sup>®</sup> interface of the PCM.

- You need a mobile phone that supports *Bluetooth*<sup>®</sup>.
- The mobile phone must support the Hands-Free Profile 1.0 or higher.
- The mobile phone must be switched on and *Bluetooth*<sup>®</sup> must be activated.
- On some mobile phones, the device must also be rendered “visible” to other devices with *Bluetooth*<sup>®</sup>.

Further information on the settings on your mobile phone can be found in the manufacturer’s operating instructions.

**i** Some mobile phones have special characteristics when it comes to *Bluetooth*<sup>®</sup> or do not fully support *Bluetooth*<sup>®</sup>. Contact your mobile phone retailer and, if applicable, download the latest software onto your mobile phone.

### Hands-free quality

The hands-free quality can be impaired by

- having the fan on, windows open or the top down,
- wind and rolling noise,
- mobile phone having a poor network connection,
- vehicle travelling at high speed.

### Interruptions to the connection while driving

Interruptions to the connection may occur if:

- there is inadequate GSM coverage in certain regions,
- you are switching from one GSM transmitting/receiving station (GSM cell) to another and there is no voice channel available in this cell,
- you are using a SIM card that is not compatible with the available network,
- you are using two SIM cards and the mobile phone is simultaneously logged into the network with the second SIM card.

### Switching *Bluetooth*<sup>®</sup> on/off

#### Switching *Bluetooth*<sup>®</sup> on

1. Press the **PHONE** button.
2. Press the **OPTION** button or touch the tab of the same name in the header.
3. Select “**SET PHONE**” > “**Bluetooth settings**”.
4. Select “**Switch on Bluetooth**”.

#### Switching *Bluetooth*<sup>®</sup> off

1. Press the **PHONE** button.
2. Press the **OPTION** button or touch the tab of the same name in the header.
3. Select “**SET PHONE**” > “**Bluetooth settings**”.
4. Select “**Switch off Bluetooth**”.



## Operating the *Bluetooth*<sup>®</sup> hands-free unit (*Bluetooth*<sup>®</sup> mobile phone preparation)

The *Bluetooth*<sup>®</sup> hands-free unit allows you to use the PCM as a hands-free unit for *Bluetooth*<sup>®</sup> mobile phones.

**i** Please note that your mobile phone must support the *Bluetooth*<sup>®</sup> Hands-Free Profile for use with the *Bluetooth*<sup>®</sup> hands-free unit.

### Authorising a mobile phone

Using the “**Find telephone**” function you can have the PCM search for and authorise your mobile phone. Follow the instructions on the PCM display for this.

For the PCM to find your *Bluetooth*<sup>®</sup> device, please ensure that the *Bluetooth*<sup>®</sup> function on the device has been activated and set to “visible”. Further details can be found in the operating manual for your mobile phone.



1. Press the **PHONE** button.
  2. Select “**Find telephone**”.  
A search is started and a list of the devices found is displayed.
  3. Select the device you want in the list.  
A *Bluetooth*<sup>®</sup> code is displayed, which you must enter on your mobile phone.
  4. Enter the displayed *Bluetooth*<sup>®</sup> code on the mobile phone.  
Successful authorisation of the device is shown on the display and the connection is established.
- i** With some mobile phones, the connection request by the PCM must be explicitly confirmed on the mobile phone. This may even have to be done a number of times in some cases, for example before transferring the phone-book. To avoid this request, you can authorise the PCM in your mobile phone's list of devices. The connection will then be established automatically in the future, without the need for further checks.  
Further details can be found in the operating manual for your mobile phone.

To find out more, please refer also to the sections „AUTHORISED *BLUETOOTH*<sup>®</sup> DEVICES“ on page 85 and „ADDING A NEW *BLUETOOTH*<sup>®</sup> DEVICE“ on page 86.

### Establishing a connection from an external *Bluetooth*<sup>®</sup> device

If the PCM does not find your mobile phone or a connection attempt by the PCM fails, you can also start the authorisation from the mobile phone.

1. If another mobile phone is connected with the PCM, switch off *Bluetooth*<sup>®</sup> on the connected mobile phone to disconnect the connection with the PCM.
  2. Press the **PHONE** button.
  3. Press the **OPTION** button or touch the tab of the same name in the header.  
The PCM is now visible for external devices.
- i** Please ensure that the *Bluetooth*<sup>®</sup> visibility of the PCM is activated. To find out more, please refer to the section „SETTING VISIBILITY“ on page 63.
4. Using the mobile phone, search for audio accessories or devices that support *Bluetooth*<sup>®</sup>. Refer to the manufacturer's operating instructions to find out how to do this.
  5. Select the device “PCM” from the mobile phone's search results and establish a connection.  
Refer to the manufacturer's operating instructions to find out how to do this.

6. A request appears on the PCM display. Select **"Accept"**.
7. A keypad appears where you enter a four-digit *Bluetooth*<sup>®</sup> code of your choice and confirm with **"OK"**.
8. Enter the same *Bluetooth*<sup>®</sup> code on your mobile phone. Once you have entered the code, successful authorisation of the device is shown on the display.
9. With many mobile phones, the connection with the PCM must be explicitly established from the mobile phone following authorisation. Further details can be found in the operating manual for your mobile phone.

**i** With some mobile phones, the *Bluetooth*<sup>®</sup> code must be directly provided by the mobile phone during the connection request. If this is the case, enter a 4-digit code of your choice on your mobile phone and confirm it with OK. You will then be shown a keypad on the PCM display where you must enter the same code and confirm it.

## Conducting calls

There are two hands-free microphones under the car's steering column trim panel. This means that you can conduct all telephone calls without using a handset.

You control the volume using the left rotary knob (🔊).

If there is a mobile phone connected to the PCM using the Hands-Free Profile, the call is normally conducted using the hands-free unit. It can, however, be transferred to the mobile phone by selecting the **"Private"** function.

- ▷ To switch the **"Private"** function on (☑) or off (☐) during the call, select **"Private"** in the call options.

## Temporarily muting the hands-free microphone

- ▷ To switch the function on (☑) or off (☐) during the call, select **"Mute microphone"** in the call options.

- i** The microphone can also be muted by:
  - briefly pressing →🔊 the left rotary knob
  - or - **(with multi-function steering wheel with telephone function)**
  - pressing the left roller on the multi-function steering wheel.



## Accepting a call

As soon as a call comes in, the current audio source is muted and the selected ringtone is played. In addition, an appropriate menu is temporarily displayed or an appropriate message is shown in the bottom line.

If available, the telephone number and name of the caller are displayed.

You can accept the incoming call in a number of ways:

- ▷ Pressing the Lift handset button 📞 on the PCM.
- or -
- ▷ Selecting **"Answer"** on the display.
- or -
- ▷ Pressing the Lift handset button 📞 on the external mobile phone.
- or - **(with multi-function steering wheel with telephone function)**
- ▷ Pressing the Lift handset button 📞 on the multi-function steering wheel.



## Ending a call

You can end an active call by:

- ▷ Pressing the End call button  on the PCM.

- or -

- ▷ Selecting “End call” in the call menu.

- or -

- ▷ Pressing the End call button  on the external mobile phone.

- or - (with multi-function steering wheel with telephone function)

- ▷ Pressing the End call button  on the multi-function steering wheel.

## Rejecting a call

You can reject an incoming call by:

- ▷ Pressing the End call button  on the PCM.

- or -

- ▷ Selecting “Reject” in the call menu.

- or -

- ▷ Briefly pressing the left rotary knob .



- or -

- ▷ Pressing the End call button  on the external mobile phone.

- or - (with multi-function steering wheel with telephone function)

- ▷ Pressing the End call button  on the multi-function steering wheel.

## Dialling a number

1. Press the **PHONE** button.  
The PHONE main menu appears.

2. Select “Dial number”.

The input menu for telephone numbers is opened. The input field for the telephone number is blank.

3. Select the individual digits in the telephone number one after the other.

 Always enter the telephone number with the dialling code.

4. Select “Call number”.

The telephone call is established and the call menu is displayed.



As soon as the telephone call has been established, a numerical keypad is displayed. This keypad allows you to dial more numbers, which are transmitted as so-called DTMF (Dual Tone Multi Frequency) tones.

To find out more, please also refer to the next section.

 Select “Call options” to close the keypad. To find out more, please refer to section „SWAPPING BACK AND FORTH BETWEEN THE KEYPAD AND CALL OPTIONS DURING A CALL.“ on page 55.

## Touch tone dialling (DTMF tones)

DTMF (Dual Tone Multi Frequency) tones can be sent once a telephone connection has been established. You need this function to communicate with touch tone-activated telephone systems (e.g. for controlling your voice mailbox or when dialling in remotely to your answering machine).

## Touch tone dialling

1. Select **“Touch tone dialling”** in the call menu.  
The numerical input menu is opened.
2. Enter the digits you want.  
Each digit is **immediately** transmitted as a DTMF tone.

## Combining DTMF tones with a telephone number

You can use the + and w characters in the numerical input menu to combine DTMF tone dialling with the entry of a telephone number.

+	The digits of the telephone number are dialled first. The PCM then waits until the connection has been established before dialling the DTMF dialling digits. ▷ To enter the + character, touch and hold the <b>0+</b> symbol in the telephone input menu.
w	The digits of the telephone number are dialled first. As soon as the connection to the telephone number dialled has been established, the DTMF dialling digits must be confirmed once more. ▷ To enter the w character, touch and hold the * symbol in the telephone input menu.

**i** The p character cannot be entered in the telephone input menu. It is, however, recognised by the PCM if it is stored in a telephone number on the SIM card, for example. In this case, the behaviour of the PCM is the same as the behaviour for “+” described above.

## Swapping back and forth between the keypad and call options during a call.

While a call is active you will see either the numerical keypad or the **“Call options”** menu. You can switch back and forth between these two displays.

**i** After a new call has been established you will always see the menu you selected when you ended the last call.

### Switching from the numerical keypad to the call options



- ▷ While a call is active, select **“Call options”** in the numerical keypad.

### Switching from the call options to the numerical keypad

- ▷ While a call is active, select **“Keypad”** in the numerical keypad.

## Using the quick dial (redial) function

Pressing the Lift handset button  on the PCM opens the quick dial menu. This menu contains a list of previous calls.



1. Press the Lift handset button  on the PCM.
2. Select the person you want to talk to.
3. Select **“Call number”** or press the Lift handset button  on the PCM again.  
- or -  
Select the first list entry, **“Dial number”**.  
The input menu for telephone numbers opens.
4. Enter the telephone number you want.
5. Select **“Call number”**.

## Using the direct dial function

If a telephone number is displayed in a menu and is highlighted, the number is dialled directly if you

- ▷ press the Lift handset button  on the PCM
- or -
- ▷ touch the displayed number for at least one second.

## Holding a call

- ▷ You can hold an active call by pressing the Lift handset button  on the PCM.  
The menu items **“New call”**, **“Activate call”** and **“End call”** are then available for you to select.
- ▷ To continue the call, press the Lift handset button  on the PCM again.

## Phonebook

After a *Bluetooth*<sup>®</sup> connection has been established between the PCM and the mobile phone, the PCM attempts to transfer the phonebook data from the mobile phone. You can prevent this automatic phonebook transfer by deactivating the **“Auto update”** function. To find out more, please refer to the section „SETTING AUTOMATIC TRANSFER OF THE PHONEBOOK“ on page 64.

## Displaying the phonebook

1. Press the **PHONE** button.  
The PHONE main menu appears.
2. Select **“Phonebook”**.  
The phonebook is opened.

### Calling a phonebook entry

1. Press the **PHONE** button.
2. Select **"Phonebook"**.
3. Select the phonebook entry you want.
4. If there is more than one number stored for this entry, select the number you want.
5. Select **"Call number"**.  
The number you want is dialed.

### Sending a vCard

You can send phonebook entries directly as vCards. A vCard is an "electronic visiting card" that a recipient can accept directly into his or her phonebook.

1. Press the **PHONE** button.
2. Select **"Phonebook"**.
3. Select the phonebook entry you want.
4. Select **"Send vCard"**.  
The list of known devices that are suitable for a transfer is displayed. If the device you want is not there, you can search for further devices. To do this, press **"New data device"** (see also the section „ADDING A NEW BLUE-TOOTH® DEVICE“ on page 86).  
As soon as the search is complete, a list containing the devices found is displayed. Once you have selected a device in this list, a connection is established and the vCard is sent.

### List of previous calls

When a mobile phone is connected to the PCM via a *Bluetooth*® connection, the mobile phone's call lists are transferred and displayed after the connection has been established. The last number dialed appears at the top of the list.

**i** The transfer of the phonebook and call lists is not supported by all mobile phones.

If one of the telephone numbers matches an entry from your phonebook, the name of the person called is displayed instead of the telephone number.

### Displaying the list

1. Press the **PHONE** button.
2. Select **"Previous calls"**.  
The list of previous calls is displayed with the time and date of the calls, if this information is available in the PCM.

### Calling a number from the list of previous calls

1. Press the **PHONE** button.
2. Select **"Previous calls"**.
3. Select the number you want.
4. Select **"Call number"**.

### Deleting a number from the list of previous calls

**i** Entries transferred from the mobile phone cannot be deleted in the PCM.  
Please delete the entries on your mobile phone.

1. Press the **PHONE** button.
2. Select **"Previous calls"**.
3. Select the number you want.
4. Select **"Delete"**.
5. Confirm the prompt that appears by selecting **"Yes"**.  
The number is deleted from the list.

### Adding to a number from the list of previous calls

1. Press the **PHONE** button.
2. Select **"Previous calls"**.
3. Select the number you want.
4. Select **"Add to number"**.  
The input menu is opened and the number is shown in the input field ready for editing.
5. Make the change you want.
6. Select **"Call number"**.  
The telephone number stored in the list is not changed.



## List of received calls

When a mobile phone is connected to the PCM via a *Bluetooth*<sup>®</sup> connection, the mobile phone's call lists are transferred and displayed after the connection has been established. The last call received appears at the top of the list.



**i** The transfer of the phonebook and call lists is not supported by all mobile phones.

**i** If the date and time information for the individual calls is not transferred from the mobile phone, the list begins with the unanswered calls. These are then followed by the accepted calls.

If one of the telephone numbers matches an entry from your phonebook, the name of the caller is displayed instead of the telephone number.

### Displaying the list

1. Press the **PHONE** button.
2. Select **"Received calls"**.

The list of received calls is displayed with the time and date of the calls, if this information is available in the PCM. It contains both accepted  and missed  calls.

**i** If a message about missed calls is shown on the display, you can access the list of received calls by touching this message.

## Calling a number from the list of received calls

1. Press the **PHONE** button.
2. Select **"Received calls"**.
3. Select the number or name you want.
4. If there is more than one telephone number stored for a name, select the number you want.
5. Select **"Call number"**.

## Deleting a number from the list of received calls

**i** Entries transferred from the mobile phone cannot be deleted in the PCM. Please delete these entries on your mobile phone.

1. Press the **PHONE** button.
2. Select **"Received calls"**.
3. Select the number you want.
4. Select **"Delete"**.
5. Confirm the prompt that appears by selecting **"Yes"**.
6. The number is deleted from the list.

## Adding to a number from the list of received calls

1. Press the **PHONE** button.
2. Select **"Received calls"**.
3. Select the number you want.
4. Select **"Add to number"**.  
The input menu is opened and the number is shown in the input field ready for editing.
5. Make the change you want.
6. Select **"Call number"**.

The telephone number stored in the list is not changed.

## Establishing an additional call

You can establish an additional call while there is another call active.

**i** Some mobile phones do not support making or accepting a second call. In this case, the **“New call”** menu item is greyed out during an active call.

1. Select **“New call”** in the call options.
2. You then have the following options for entering the telephone number:
  - **“Dial number”**:  
The input menu for telephone numbers is opened. Please refer to the section „USING THE QUICK DIAL (REDIAL) FUNCTION“ on page 55.
  - **“Phonebook”**:  
You can insert a number stored in the phonebook. To find out more, please refer to the section „CALLING A PHONEBOOK ENTRY“ on page 56.
  - **“Previous calls”**:  
You can insert a telephone number from the list of previous calls. To find out more, please refer to the section „CALLING A NUMBER FROM THE LIST OF PREVIOUS CALLS“ on page 56.

### – **“Received calls”**:

You can insert a telephone number from the list of received calls. To find out more, please refer to the section „CALLING A NUMBER FROM THE LIST OF RECEIVED CALLS“ on page 57.

The original call is held while the new connection is established.

You can switch between the two calls or establish a conference call. To find out more, please refer to the section „CALL WAITING (SWAPPING) AND CONFERENCE“ on page 59.

## Call waiting

The **“Call waiting”** function is only available if supported by the network provider and by the mobile phone.

The **“Call waiting”** function must also be activated in the call settings of the mobile phone. To find out more, please refer also to the section „CALL WAITING (SWAPPING) AND CONFERENCE“ on page 59.

## Rejecting a waiting call

If you receive another call while there is already one active, you will hear a call waiting tone. The menu for the incoming call is displayed and a message appears in the bottom line.

- ▷ Select **“Reject”**.  
The waiting call is rejected. The caller hears a busy signal.  
If the caller’s telephone number is transmitted, the number or name appears in the **“Received calls”** list.

## Accepting a waiting call

- ▷ Select **“Answer”**.  
The waiting call is accepted and activated. The previously active call is put on hold.  
You then have the option to switch between the two calls or to establish a conference with both callers. To find out more, please refer to the section „CALL WAITING (SWAPPING) AND CONFERENCE“.

The PCM will not accept a third incoming call. The caller hears a busy signal or is redirected to the mailbox.

## Ending a connected call

- ▷ Select **“End connected call”**.  
The currently active call is ended and the first call that is on hold is activated again.

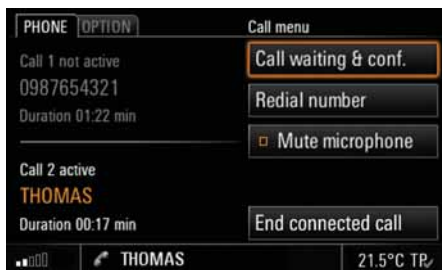

### Call waiting (swapping) and conference

The “**Call waiting & conf.**” function is only available if supported by the network provider and by the mobile phone.

When using the *Bluetooth*<sup>®</sup> hands-free unit, this function is only available for a limited selection of devices.

A prerequisite for this function is that there are two calls, one of which is connected (active) and one of which is on hold (inactive). To find out more, please refer to the sections „ESTABLISHING AN ADDITIONAL CALL“ on page 58 and „ACCEPTING A WAITING CALL”.

- ▷ Select “**Call waiting & conf.**”.

You now have a number of options:

### Swapping between the calls (call waiting)

1. Select “**Swap**”.  
The system swaps to the other call. The previously active call is put on hold.
2. Select “**Swap**” again to return to the call on hold.
3. To end one of the two calls, select “**End call 1**” or “**End call 2**”.  
- or -  
Select “**End all**” to end both calls.

### Conferencing the two calls

1. Select “**Conference**”.  
Both calls are activated and connected so that all parties can speak to each other.
2. To end one of the two calls, select “**End call 1**” or “**End call 2**”.  
- or -  
Select “**End all**” to end the conference.

### Speed dialling

Speed dialling is a frequently used function in the US market, which allows dialling without having to enter the complete telephone number. Instead, you can enter the number of a memory location on the SIM card followed by the “#” character to dial the corresponding telephone number.

**i** The speed dialling function is only available if supported by your mobile phone.

1. Press the **PHONE** button.  
The PHONE main menu appears.
2. Select “**Dial number**”.  
The input menu for telephone numbers is opened.
3. Select the individual digits of the memory location on the SIM card one after the other.
4. Select the “#” character.
5. Select “**Call number**”.  
The corresponding telephone number is inserted and dialled. The call menu is displayed.

## Telephone settings (*Bluetooth*<sup>®</sup> mobile phone preparation)

### Setting the ringtone type

1. Press the **PHONE** button.
2. Press the **OPTION** button or touch the tab of the same name in the header.
3. Select “**Telephone settings**”  
> “**Ringtone type**”.  
A list of the available ringtones is displayed.
4. Set the ringtone you want by selecting it.  
After a ringtone is selected, it is played back again.
5. Change the volume of the ringtone type if necessary by turning the left rotary knob (●).  
The volume level set in this way is saved when you exit the menu.

**i** If the connected mobile phone supports the transfer of the ringtone via *Bluetooth*<sup>®</sup> (inband ringing), the Ringtone settings item is greyed out and the ringtone must be set on the mobile phone.

### Setting the ringtone volume

1. Press the **PHONE** button.
2. Press the **OPTION** button or touch the tab of the same name in the header.
3. Select “**Telephone settings**”  
> “**Ringtone volume**”.
4. Make the setting you want by turning the right rotary knob (●) or by selecting the two symbols ▲ and ▼.

### Setting the call volume

**i** The implementation of audio transmission via *Bluetooth*<sup>®</sup> often depends on the specific mobile phone implementation. If the volume in the vehicle or for the called party is insufficient, it can be readjusted in the PCM.

1. Press the **PHONE** button.
2. Press the **OPTION** button or touch the tab of the same name in the header.
3. Select “**Telephone settings**”  
> “**Call volume**”.
4. Make the setting you want by turning the right rotary knob (●) or by selecting the two symbols ▲ and ▼.

### Setting the microphone volume

1. Press the **PHONE** button.
2. Press the **OPTION** button or touch the tab of the same name in the header.
3. Select “**Telephone settings**”  
> “**Mic volume**”.
4. Make the setting you want by turning the right rotary knob (●) or by selecting the two symbols ▲ and ▼.

### Switching 3-way calling on/off



Problems may occur with 3-way calling on the PCM as these functions are not correctly supported by all mobile phones and telephone networks (in particular CDMA networks). It is recommended that 3-way calling be switched off in such cases in order to ensure reliable telephone operation.

1. Press the **PHONE** button.
2. Press the **OPTION** button or touch the tab of the same name in the header.
3. Select “**Telephone settings**”.
4. Select “**3-way calling**” to activate (☑) or deactivate (☐) the function.

## Bluetooth® settings (Bluetooth® mobile phone preparation)

### Authorised Bluetooth® devices

This function allows you to display a list of the Bluetooth® devices currently authorised to connect with your PCM. The list contains:

- mobile phones ,
- MP3 players  as well as
- data devices .

### Displaying authorised Bluetooth® devices

1. Press the **PHONE** button.
2. Press the **OPTION** button or touch the tab of the same name in the header.
3. Select “Bluetooth settings”

> “Device list”.

The list is opened.

Devices that can be connected with the PCM using different profiles appear only once in the list. The symbol used always corresponds to the main application. Mobile phones that can also be used as MP3 players or data devices appear in this list with the telephone symbol.

### Connecting an authorised Bluetooth® device with the PCM

1. Open the list of authorised Bluetooth® devices.
2. Select the device you want in the list.
3. Select “Connect”.

**i** Data devices cannot be connected from the list of devices; they can only be connected by calling the appropriate application, for example when transferring a vCard.

### Disconnecting an authorised and connected Bluetooth® device from the PCM

1. Open the list of authorised Bluetooth® devices.
2. Select the device you want in the list.
3. Select “Disconnect”.

### Renaming an authorised Bluetooth® device

1. Open the list of authorised Bluetooth® devices.
2. Select the device you want in the list.
3. Select “Rename”.  
The input menu is opened.
4. Enter the name you want and confirm by selecting “OK”.  
The name of the device is now changed in the PCM.

### Deleting an authorised Bluetooth® device from the list

1. Open the list of authorised Bluetooth® devices.
2. Select the device you want in the list.
3. Select “Delete”.
4. Confirm the prompt that appears by selecting “Yes”.



### Deleting the list of authorised Bluetooth® devices

1. Open the list of authorised Bluetooth® devices.
2. Select any device in the list.
3. Select “Delete”.
4. Select “Delete list”.
5. Confirm the prompt that appears by selecting “Delete all”.

### Displaying details for the authorised Bluetooth® device

1. Open the list of authorised Bluetooth® devices.
2. Select any device in the list.
3. Select “Device details”.

The following information is displayed:

- the device name,
- the Bluetooth® address,
- the connection quality as well as
- the supported services.

## Adding a new *Bluetooth*<sup>®</sup> device

For the PCM to find your *Bluetooth*<sup>®</sup> device, please ensure that the *Bluetooth*<sup>®</sup> function on the device has been activated and set to “visible”.

1. Press the **PHONE** button.
2. Press the **OPTION** button or touch the tab of the same name in the header.
3. Select “**Bluetooth settings**”  
> “**New device**”.

A search is started and a list of the devices found is displayed.

4. Choose the device you want by selecting it in the list.

A *Bluetooth*<sup>®</sup> code is displayed that you must enter in the corresponding *Bluetooth*<sup>®</sup> device. Once you have entered the code, successful authorisation of the device is shown on the display.

5. With mobile phones, the connection is automatically established by the PCM.

**i** With some mobile phones, the connection request by the PCM must be explicitly confirmed on the mobile phone. This may even have to be done a number of times in some cases, for example before transferring the phone-book. To avoid this request, you can authorise the PCM in your mobile phone’s list of devices. The connection will then be established automatically in the future, without the need for further checks.

▷ ▷ ▷

It can take a few seconds for the *Bluetooth*<sup>®</sup> device to be authorised.

If the list of authorised *Bluetooth*<sup>®</sup> devices is full (max. 5 mobile phones), you must first delete a device from the list. An appropriate message will be displayed. To find out more, please refer to the section „DELETING AN AUTHORISED *BLUETOOTH*<sup>®</sup> DEVICE FROM THE LIST“ on page 61.

## Establishing a connection from an external *Bluetooth*<sup>®</sup> device

If the PCM does not find your mobile phone or a connection attempt by the PCM fails, you can also start the authorisation from the mobile phone.

1. If another mobile phone is connected with the PCM, switch off *Bluetooth*<sup>®</sup> on the connected mobile phone to disconnect the connection with the PCM.
2. Press the **PHONE** button.
3. Press the **OPTION** button or touch the tab of the same name in the header.  
The PCM is now visible for external devices.

**i** Please ensure that the *Bluetooth*<sup>®</sup> visibility of the PCM is activated. To find out more, please see the following section.

4. Using the mobile phone, search for audio accessories or devices that support *Bluetooth*<sup>®</sup>. Refer to the manufacturer’s operating instructions to find out how to do this.

5. Select the device “PCM” from the mobile phone’s search results and establish a connection.

Refer to the manufacturer’s operating instructions to find out how to do this.

6. A request appears on the PCM display. Select “**Accept**”.
  7. A keypad appears where you enter a four-digit *Bluetooth*<sup>®</sup> code of your choice and confirm with “**OK**”.
  8. Enter the same *Bluetooth*<sup>®</sup> code on your mobile phone.  
Once you have entered the code, successful authorisation of the device is shown on the display.
  9. With many mobile phones, the connection with the PCM must be explicitly established from the mobile phone following authorisation. Further details can be found in the operating manual for your mobile phone.
- i** With some mobile phones, the *Bluetooth*<sup>®</sup> code must be directly provided by the mobile phone during the connection request. If this is the case, enter a 4-digit code of your choice on your mobile phone and confirm it with OK. You will then be shown a keypad on the PCM display where you must enter the same code and confirm it.

## Setting visibility

To ensure that your PCM can be found by other devices via the *Bluetooth*<sup>®</sup> interface, it must be “visible” (=recognisable) for other devices during the search.

To prevent further unwanted connection requests, you can deactivate visibility of the PCM after the connection operation.

1. Press the **PHONE** button.
2. Press the **OPTION** button or touch the tab of the same name in the header.
3. Select “**Bluetooth settings**”.
4. Select “**PCM visible**” to activate () or deactivate () visibility of the PCM.

## Phonebook settings (*Bluetooth*<sup>®</sup> mobile phone preparation)

### Setting the memory for the phonebook

You can set which phonebook entries should be shown in the PCM phonebook display:

- phonebook entries on the SIM card and/or
- phonebook entries in the telephone’s memory.

This allows you to adapt the phonebook list of the PCM to your list in the mobile phone.

1. Press the **PHONE** button.
2. Press the **OPTION** button or touch the tab of the same name in the header.
3. Select “**Phonebook settings**”  
> “**Phonebook memory**”.
4. Make the setting you want by selecting it.

### Setting sorting

You can adapt the sorting of the phonebook and call lists to the display on your mobile phone.

You have the following options for **sorting the phonebook**:

- “**Standard**”  
The phonebook is sorted by surname.
- “**Alternative**”  
The phonebook is sorted by first name.

You have the following options for **sorting the call lists**:

- “**Standard**”  
The call lists are sorted in the same order in which the entries were transferred from the mobile phone.
  - “**Alternative**”  
The order of the entries transferred from the mobile phone is reversed. This option supports some mobile phones that transfer the oldest entries first.
1. Press the **PHONE** button.
  2. Press the **OPTION** button or touch the tab of the same name in the header.
  3. Select “**Phonebook settings**”  
> “**Sorting**”.

### Setting sorting of the phonebook

4. Select “**Phonebook**”.
5. Select the sorting you want.

### Setting sorting of the call lists

4. Select “**Call lists**”.
5. Select the sorting you want.

## Setting automatic transfer of the phonebook

If the “**Auto update**” function is activated, the phonebook of a mobile phone is transferred as soon as the PCM is connected to this mobile phone.

As soon as the transfer is complete, the phonebook stored in the PCM is replaced by the current phonebook from the mobile phone.

If the “**Auto update**” function is deactivated, the data will no longer be updated.

1. Press the **PHONE** button.
2. Press the **OPTION** button or touch the tab of the same name in the header.
3. Select “**Phonebook settings**”.
4. Select “**Auto update**” to activate () or deactivate () the function.

**i** Your phonebook data can then only be accessed when the corresponding mobile phone is connected to the PCM.

## Transferring the phonebook

This function transfers the phonebook of the connected mobile phone into the PCM again. The phonebook stored in the PCM is replaced by the current phonebook from the mobile phone once transfer is complete.

1. Press the **PHONE** button.
2. Press the **OPTION** button or touch the tab of the same name in the header.
3. Select “**Transfer phonebook**”.

## Transferring the phonebook entries manually

Some mobile phones do not support automatic phonebook transfer. In these cases, you can load entries from your mobile phone’s phonebook into the PCM phonebook manually.

1. Press the **PHONE** button.
2. Press the **OPTION** button or touch the tab of the same name in the header.
3. Select “**Transfer phonebook**”.
4. You can now choose whether to add to the phonebook or completely replace it. Select the function you want.
5. Select the entries you want from your mobile phone and transfer them to the PCM via Bluetooth. The PCM counts the entries already transferred.
6. When transfer is complete, select “**Ready**”. The transferred entries are now available to you in the PCM phonebook.

## Deleting the phonebook

The copy of the phonebook transferred to the PCM can be deleted again.

Your mobile phone’s phonebook remains unchanged.

1. Press the **PHONE** button.
2. Press the **OPTION** button or touch the tab of the same name in the header.
3. Select “**Delete phonebook**”.



## Operating the PCM telephone

A SIM card is required if you want to use the internal PCM telephone in telephone mode. You can

- insert the SIM card in the slot provided under the display or
- connect a suitable mobile phone to the PCM via the *Bluetooth*<sup>®</sup> SIM Access Profile.

To find out more, please refer to the sections „CONNECTING AN AUTHORISED *BLUETOOTH*<sup>®</sup> DEVICE WITH THE PCM“ on page 85 and „ADDING A NEW *BLUETOOTH*<sup>®</sup> DEVICE“ on page 86.

**i** Please note that your mobile phone must support the *Bluetooth*<sup>®</sup> Hands-Free Profile or the *Bluetooth*<sup>®</sup> SIM Access Profile for use with the PCM telephone.



### Inserting the SIM card in the PCM

- ▷ Push the SIM card (SIM = **S**ubscriber **I**dentification **M**odule) into the slot provided until it engages.

To remove the SIM card, press the card into the slot again until it stops.

Insert the SIM card so that the metal contacts are on the underside. The slanted corner of the SIM card must be on the **rear left**.

- i** The use of twin SIM cards, for example in the mobile phone and the internal PCM telephone (both cards active at the same time), may impair the telephone functions. For more information on this, contact your network provider.

If there is no SIM card inserted in the slot, the PCM automatically attempts to establish a *Bluetooth*<sup>®</sup> connection with a mobile phone. However, this is only possible if you have

- activated *Bluetooth*<sup>®</sup> on the PCM and on the mobile phone and
- authorised at least one mobile phone on the PCM.

If you have not yet authorised a mobile phone on the PCM, you can select “**Find telephone**” to have the PCM search for and authorise your mobile phone. Follow the instructions on the display.

You can find more information in the sections „AUTHORISED *BLUETOOTH*<sup>®</sup> DEVICES“ on page 85 and „ADDING A NEW *BLUETOOTH*<sup>®</sup> DEVICE“ on page 86.

### Entering the PIN

As soon as you have switched on the telephone and inserted the SIM card, you are prompted to enter the PIN (PIN = **P**ersonal **I**dentification **N**umber).

You will find the PIN in the documentation you received from your network provider.

1. Enter the PIN by selecting the keys on the keypad shown.  
The numbers entered will be shown as asterisks in the input field.
2. Confirm your entry by selecting “**OK**”.

**i** The SIM card will be blocked if you enter the wrong PIN three times in a row. To unblock the card, you must enter the PUK (**P**in **U**nblocking **K**ey). Follow the instructions on the PCM display to do this.

The SIM card will be blocked if you enter the wrong PUK ten times in a row. This block can only be removed by the network provider.

You can deactivate the PIN prompt after the device is switched on. To find out more, please refer to the sections „SWITCHING THE PIN PROMPT ON OR OFF“ on page 82 and „USING A STORED PIN“ on page 82.

## Conducting calls

There are two hands-free microphones under the car's steering column trim panel. This means that you can conduct all telephone calls without using a handset.

You control the volume using the left rotary knob (🔊).

### Conducting a call using a headset

1. Select **“Hands-free”** in the call options to switch to hands-free mode.
2. Select **“Headset”** in the call menu to end hands-free mode. The call is transferred back to the handset.

**i** The call can only be conducted using a headset if it has previously been connected with the PCM via *Bluetooth*®.

To find out more, please refer to the sections „AUTHORISED BLUETOOTH® DEVICES“ on page 85 and „ADDING A NEW BLUETOOTH® DEVICE“ on page 86.

### Conducting a call using the cordless handset

1. Select **“Hands-free”** in the call options to switch to hands-free mode.
2. Press the Lift handset button on the handset to terminate hands-free mode. The call is transferred back to the handset. To find out more, please refer to the section „CORDLESS HANDSET“ on page 89.

### Temporarily muting the hands-free microphone

- ▷ To switch the function on (🔇) or off (🔊) during the call, select **“Mute microphone”** in the call options.

**i** The microphone can also be muted by:

- briefly pressing →🔊 the left rotary knob
- or - **(with multi-function steering wheel with telephone function)**
- pressing the left roller on the multi-function steering wheel.



### Accepting a call

As soon as a call comes in, an appropriate menu is temporarily displayed or an appropriate message shown in the bottom line.

If available, the telephone number and name of the caller are displayed.

You can accept the incoming call in a number of ways:

- ▷ Pressing the Lift handset button (📞) on the PCM.

- or -

- ▷ Selecting **“Answer”** on the display.

- or - **(with multi-function steering wheel with telephone function)**

- ▷ Pressing the Lift handset button (📞) on the multi-function steering wheel.

- or - **(with handset if available)**

- ▷ Pressing the Lift handset button (📞) on the handset.

- or -

- ▷ Removing the handset from the charging cradle.



### Ending a call

You can end an active call by:

- ▷ Pressing the End call button  on the PCM.

- or -

- ▷ Selecting “End call” in the call menu.

- or - (with multi-function steering wheel with telephone function)

- ▷ Pressing the End call button  on the multi-function steering wheel.

- or - (with handset if available)

- ▷ Pressing the End call button  on the handset.

- or -

- ▷ Placing the handset in the charging cradle (if the call is on the handset).

### Rejecting a call

You can reject an incoming call by:

- ▷ Pressing the End call button  on the PCM.

- or -

- ▷ Selecting “Reject” in the call menu.

- or -

- ▷ Briefly pressing the left rotary knob .



- or - (with multi-function steering wheel with telephone function)

- ▷ Pressing the End call button  on the multi-function steering wheel.

- or - (with handset if available)

- ▷ Pressing the End call button  on the handset.

### Dialling a number

1. Press the **PHONE** button.  
The PHONE main menu appears.
2. Select “Dial number”.  
The input menu for telephone numbers is opened. The input field for the telephone number is blank.
3. Select the individual digits in the telephone number one after the other.  
 Always enter the telephone number with the dialling code.
4. Select “Call number”.  
The telephone call is established and the call menu is displayed.



As soon as the telephone call has been established, a numerical keypad is displayed. This keypad allows you to dial more numbers, which are transmitted as so-called DTMF (Dual Tone Multi Frequency) tones.

To find out more, please also refer to the next section.

-  Select “Call options” to close the keypad. To find out more, please refer to section „SWAPPING BACK AND FORTH BETWEEN THE KEYPAD AND CALL OPTIONS DURING A CALL.“ on page 55.

### Touch tone dialling (DTMF tones)

DTMF (Dual Tone Multi Frequency) tones can be sent once a telephone connection has been established. You need this function to communicate with touch tone-activated telephone systems (e.g. for controlling your voice mailbox or when dialling in remotely to your answering machine).

## Touch tone dialling

1. Select “**Touch tone dialling**” in the call menu.  
The numerical input menu is opened.
2. Enter the digits you want.  
Each digit is **immediately** transmitted as a DTMF tone.

## Combining DTMF tones with a telephone number

You can use the + and w characters in the numerical input menu to combine DTMF tone dialling with the entry of a telephone number.

+	The digits of the telephone number are dialled first. The PCM then waits until the connection has been established before dialling the DTMF dialling digits. ▷ To enter the + character, touch and hold the <b>0+</b> symbol in the telephone input menu.
w	The digits of the telephone number are dialled first. As soon as the connection to the telephone number dialled has been established, the DTMF dialling digits must be confirmed once more. ▷ To enter the w character, touch and hold the * symbol in the telephone input menu.

**i** The p character cannot be entered in the telephone input menu. It is, however, recognised by the PCM if it is stored in a telephone number on the SIM card, for example. In this case, the behaviour of the PCM is the same as the behaviour for “+” described above.

## Swapping back and forth between the keypad and call options during a call.

While a call is active you will see either the numerical keypad or the “**Call options**” menu. You can switch back and forth between these two displays.

**i** After a new call has been established you will always see the menu you selected when you ended the last call.

## Switching from the numerical keypad to the call options



- ▷ While a call is active, select “**Call options**” in the numerical keypad.

## Switching from the call options to the numerical keypad

- ▷ While a call is active, select “**Keypad**” in the numerical keypad.

## Using the quick dial (redial) function

Pressing the Lift handset button  on the PCM opens the quick dial menu. This menu contains a list of previous calls.



1. Press the Lift handset button  on the PCM.
2. Select the person you want to talk to.
3. Select “**Call number**” or press the Lift handset button  on the PCM again.  
- or -  
Select the first list entry, “**Dial number**”.  
The input menu for telephone numbers opens.
4. Enter the telephone number you want.
5. Select “**Call number**”.

## Using the direct dial function

If a telephone number is displayed in a menu and is highlighted, the number is dialled directly if you

- ▷ press the Lift handset button  on the PCM
- or -
- ▷ touch the displayed number for at least one second.

## Holding a call

- ▷ You can hold an active call by pressing the Lift handset button  on the PCM.  
The menu items “**New call**”, “**Activate call**” and “**End call**” are then available for you to select.
- ▷ To continue the call, press the Lift handset button  on the PCM again.

## PCM phonebook

After you insert a SIM card, the phonebook entries are transferred from the SIM card to the PCM.

After a *Bluetooth*<sup>®</sup> connection has been established between the PCM and the mobile phone, the PCM also attempts to transfer the phonebook data from the mobile phone. You can prevent this automatic phonebook transfer by deactivating the “**Auto update**” function. To find out more, please refer to the section „SETTING AUTOMATIC TRANSFER OF THE PHONEBOOK“ on page 64.

### Displaying the phonebook

1. Press the **PHONE** button.

The PHONE main menu appears.

2. Select “**Phonebook**”.

The phonebook is opened.

If no entries have been stored in it yet, “**List empty**” is displayed.

If entries have already been stored, these are shown in a list.

### Calling a phonebook entry

1. Press the **PHONE** button.
2. Select “**Phonebook**”.
3. Select the phonebook entry you want.
4. If there is more than one number stored for this entry, select the number you want.
5. Select “**Call number**”.

The number you want is dialled.

### Creating and storing a phonebook entry (only with the SIM card inserted)

1. Press the **PHONE** button.
2. Select “**Phonebook**”.
3. Select “**New entry**” at the end of the list.
4. Select “**Name**”.  
The input menu is opened.
5. Enter the name you want by selecting the individual letters in the input menu and confirm your entry by pressing “**OK**”.
6. Select “**Number**”.
7. Enter the number you want by selecting the individual digits in the input menu and confirm your entry by pressing “**OK**”.
8. Select “**Store entry**”.

The entry is stored on the SIM card.

**i** The telephone number must be entered with a dialling code (there are a few exceptions to this). For overseas telephone calls you must also specify the international dialling code.

**Example:** For Germany, you must enter +491 7XXX instead of 017XXX if you will be dialling the number from outside the country.

### Editing a phonebook entry (only with the SIM card inserted)

1. Press the **PHONE** button.
2. Select “**Phonebook**”.
3. Select the phonebook entry you want.
4. Select “**Edit**”.
5. Select the menu item to be edited and make the change you want in the relevant input menu.
6. Confirm your entry by selecting “**OK**”.
7. Select “**Store entry**”.  
The entry is stored on the SIM card.

### Deleting a phonebook entry (only with the SIM card inserted)

1. Press the **PHONE** button.
2. Select “**Phonebook**”.
3. Select the phonebook entry you want.
4. Select “**Delete**”.  
A prompt is displayed asking whether the entry selected should actually be deleted.
5. Confirm the prompt by selecting “**Yes**”.  
The phonebook entry is deleted.

### Deleting the contents of the SIM card (only with the SIM card inserted)

1. Press the **PHONE** button.
2. Select “**Phonebook**”.
3. Select any phonebook entry.
4. Select “**Delete**”.
5. Select “**Delete SIM card**”.
6. Confirm the prompt which then appears with “**Delete all**”.

## Sending a vCard

You can send phonebook entries directly as vCards. A vCard is an “electronic visiting card” that a recipient can accept directly into his or her phonebook.

1. Press the **PHONE** button.
2. Select “**Phonebook**”.
3. Select the phonebook entry you want.
4. Select “**Send vCard**”.
5. Select one of the two following transfer methods:
  - “**As SMS**”
  - “**To Bluetooth**”
6. If you choose “**As SMS**”, you must enter the telephone number of the recipient in the input menu that appears.

You can also select the number from the phonebook or call lists by selecting the corresponding menu item. To find out more, please refer to the section „CREATING AND SENDING A NEW TEXT MESSAGE“ on page 76.

If you choose “**To Bluetooth**”, the list of known devices that are suitable for a transfer is displayed. If the device you want is not there, you can search for further devices. To do this, press “**New data device**” (see also the section „ADDING A NEW BLUETOOTH® DEVICE“ on page 86).

As soon as the search is complete, a list containing the devices found is displayed. Once you have selected a device in this list, a connection is established and the vCard is sent.

**i** You can also send a destination entry from the personal destination memory of your navigation system as a vCard. To find out more about this, please refer to the section „SENDING A DESTINATION“ on page 133.

## List of previous calls

When a mobile phone is connected to the PCM via a *Bluetooth*® connection, the mobile phone's call lists are transferred and displayed after the connection has been established. The last number dialled appears at the top of the list.

**i** The transfer of the phonebook and call lists is not supported by all mobile phones.

If one of the telephone numbers matches an entry from your phonebook, the name of the person called is displayed instead of the telephone number.

## Displaying the list

1. Press the **PHONE** button.
2. Select “**Previous calls**”.

The list of previous calls is displayed with the time and date of the calls, if this information is available in the PCM.

## Calling a number from the list of previous calls

1. Press the **PHONE** button.
2. Select “**Previous calls**”.
3. Select the number you want.
4. Select “**Call number**”.

## Storing a number from the list of previous calls in the phonebook

This function is only available when there is a SIM card inserted.

1. Press the **PHONE** button.
2. Select “**Previous calls**”.
3. Select the number you want.
4. Select “**Store number**”.
5. Enter the name corresponding to the number and store the entry.  
To find out more, please refer to the section „PCM PHONEBOOK“ on page 69.

## Deleting a number from the list of previous calls

**i** Entries transferred from the mobile phone cannot be deleted in the PCM. Please delete these entries on your mobile phone.

1. Press the **PHONE** button.
2. Select “**Previous calls**”.
3. Select the number you want.
4. Select “**Delete**”.
5. Confirm the prompt that appears by selecting “**Yes**”.

The number is deleted from the list.

## Sending a message to a number from the list of previous calls

**i** Messages can only be sent when a SIM card is inserted or a mobile phone is connected to the PCM using the SIM Access Profile.

1. Press the **PHONE** button.
2. Select “**Previous calls**”.
3. Select the number you want.
4. Select “**Send message**”.

The SMS input menu is opened. The number previously chosen is already entered as the recipient.

5. Enter and send your message.

To find out more, please refer to the section „REPLYING TO A TEXT MESSAGE“ on page 75.

## Adding to a number from the list of previous calls

1. Press the **PHONE** button.
2. Select “**Previous calls**”.
3. Select the number you want.
4. Select “**Add to number**”.

The input menu is opened and the number is shown in the input field ready for editing.

5. Make the change you want.
6. Select “**Call number**”.

The telephone number stored in the list is not changed.

## List of received calls

When a mobile phone is connected to the PCM via a *Bluetooth*<sup>®</sup> connection, the mobile phone's call lists are transferred and displayed after the connection has been established. The last call received appears at the top of the list.



**i** The transfer of the phonebook and call lists is not supported by all mobile phones.

**i** If the date and time information for the individual calls is not transferred from the mobile phone, the list begins with the unanswered calls. These are then followed by the accepted calls.

If one of the telephone numbers matches an entry from your phonebook, the name of the caller is displayed instead of the telephone number.

### Displaying the list

1. Press the **PHONE** button.
2. Select “**Received calls**”.

The list of received calls is displayed with the time and date of the calls, if this information is available in the PCM. It contains both accepted  and missed  calls.

**i** If a message about missed calls is shown on the display, you can access the list of received calls by touching this message.

## Calling a number from the list of received calls

1. Press the **PHONE** button.
2. Select “**Received calls**”.
3. Select the number or name you want.
4. If there is more than one telephone number stored for a name, select the number you want.
5. Select “**Call number**”.

## Storing a number from the list of received calls in the phonebook

This function is only available when there is a SIM card inserted.

1. Press the **PHONE** button.
2. Select “**Received calls**”.
3. Select the number you want.
4. Select “**Store number**”.
5. Enter the details you want.

Please refer to the section „PCM PHONE-BOOK“ on page 69.

### Deleting a number from the list of received calls

Entries transferred from the mobile phone cannot be deleted in the PCM. Please delete these entries on your mobile phone.

1. Press the **PHONE** button.
2. Select **“Received calls”**.
3. Select the number you want.
4. Select **“Delete”**.
5. Confirm the prompt that appears by selecting **“Yes”**.
6. The number is deleted from the list.

### Sending a message to a number from the list of received calls

**i** Messages can only be sent when a SIM card is inserted or a mobile phone is connected to the PCM using the SIM Access Profile.

1. Press the **PHONE** button.
2. Select **“Received calls”**.
3. Select the number you want.
4. Select **“Send message”**.  
The SMS input menu is opened. The number previously chosen is already entered as the recipient.
5. Enter and send your message.  
To find out more, please refer to the section „REPLYING TO A TEXT MESSAGE“ on page 75.

### Adding to a number from the list of received calls

1. Press the **PHONE** button.
2. Select **“Received calls”**.
3. Select the number you want.
4. Select **“Add to number”**.  
The input menu is opened and the number is shown in the input field ready for editing.
5. Make the change you want.
6. Select **“Call number”**.

The telephone number stored in the list is not changed.

### Establishing an additional call

You can establish an additional call while there is another call active.

- i** Some mobile phones do not support making or accepting a second call. In this case, the **“New call”** menu item is greyed out during an active call.
1. Select **“New call”** in the call options.

2. You then have the following options for entering the telephone number:

– **“Dial number”**:

The input menu for telephone numbers is opened. Please refer to the section „DIALING A NUMBER“ on page 67.

– **“Phonebook”**:

You can insert a number stored in the phonebook. To find out more, please refer to the section „CALLING A PHONEBOOK ENTRY“ on page 69.

– **“Previous calls”**:

You can insert a telephone number from the list of previous calls. To find out more, please refer to the section „CALLING A NUMBER FROM THE LIST OF PREVIOUS CALLS“ on page 70.

3. **“Received calls”**:

You can insert a telephone number from the list of received calls. To find out more, please refer to the section „STORING A NUMBER FROM THE LIST OF RECEIVED CALLS IN THE PHONEBOOK“ on page 71.

The original call is held while the new connection is established.

You can switch between the two calls or establish a conference call. To find out more, please refer to the section „CALL WAITING (SWAPPING) AND CONFERENCE“ on page 73.



## Call waiting

The “**Call waiting**” function is only available if supported by the network provider.

The “**Call waiting**” function must also be activated in the call settings for the PCM or the mobile phone. To find out more, please refer also to the section „CALL WAITING (SWAPPING) AND CONFERENCE“ on page 59.

## Rejecting a waiting call

If you receive another call while there is already one active, you will hear a call waiting tone.

The menu for the incoming call is displayed and a message appears in the bottom line.

- ▷ Select “**Reject**”.

The waiting call is rejected. The caller hears a busy signal.

If the caller’s telephone number is transmitted, the number or name appears in the “**Received calls**” list.

## Accepting a waiting call

- ▷ Select “**Answer**”.

The waiting call is accepted and activated. The previously active call is put on hold.

You then have the option to switch between the two calls or to establish a conference with both callers. To find out more, please refer to the section „CALL WAITING (SWAPPING) AND CONFERENCE“ on page 73.

The PCM will not accept a third incoming call.

The caller hears a busy signal or is redirected to the mailbox.

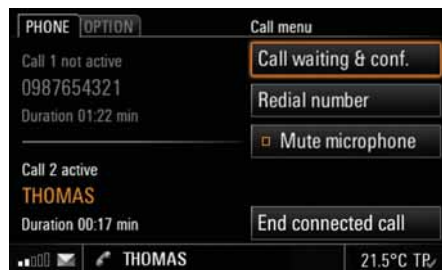

## Ending a connected call

- ▷ Select “**End connected call**”.

The currently active call is ended and the first call that is on hold is activated again.

## Call waiting (swapping) and conference

The “**Call waiting & conf.**” function is only available if supported by the network provider and by the mobile phone.

When using the *Bluetooth*® hands-free unit, this function is only available for a limited selection of devices.

A prerequisite for this function is that there are two calls, one of which is connected (active) and one of which is on hold (inactive). To find out more, please refer to the sections „ESTABLISHING AN ADDITIONAL CALL“ on page 58 and „ACCEPTING A WAITING CALL”.

- ▷ Select “**Call waiting & conf.**”.

You now have a number of options:

## Swapping between the calls (call waiting)

1. Select “**Swap**”.

The system swaps to the other call. The previously active call is put on hold.

2. Select “**Swap**” again to return to the call on hold.
3. To end one of the two calls, select “**End call 1**” or “**End call 2**”.

- or -

Select “**End all**” to end both calls.

## Conferencing the two calls

1. Select “**Conference**”.

Both calls are activated and connected so that all parties can speak to each other.

2. To end one of the two calls, select “**End call 1**” or “**End call 2**”.

- or -

Select “**End all**” to end the conference.

## Using supplementary services

Supplementary services are services that can be called up using star and hash codes.

The supplementary services can either be entered in the number selection menu or selected in the phonebook (provided they have been stored here).

The last digit of a supplementary service is always the # character.

1. Press the **PHONE** button.
2. Select **"Dial number"**.  
The input menu for telephone numbers is opened.
3. Select the individual digits and symbols of the supplementary service one after the other.
4. Select **"Send"**.  
The respective service is called up.  
If the reply text is too long, it is truncated at the bottom right with "...".
5. If necessary, display the entire text by selecting **"Details"**.

## Making an emergency call

1. Press the **PHONE** button.
2. Select **"OPTION"**.
3. Select **"Emergency call"**.
4. Select one of the two menu items in the emergency call menu that appears:

– **Yes**

If you select **"Yes"**, a connection is established to the emergency service.

– **No**

If you select **"No"**, no emergency call is made. Instead the previous menu is opened again.

**i** You can also make an emergency call:

- during an active call,
- without having to enter a PIN,
- while the SIM card is being checked as well as
- without a valid SIM card (depending on the country and network).

If your vehicle is equipped with a navigation system, you can call up the current location information in the event of an emergency call. To do this, select the **"Location info"** function.

## Text messages (SMS) (with PCM telephone only)

You can send and receive text messages (SMS) with the **Messages** function.

1. Press the **PHONE** button.
2. Select **"Messages"**.

The list of received text messages is opened. Small symbols indicate the status or type of the text messages:

 unread text message,

 read text message,

 unread vCard,

 read vCard.

vCards can be sent by other devices to the PCM via *Bluetooth*<sup>®</sup> or SMS.

### Arrival of a text message

When a new text message arrives, a closed envelope symbol is displayed in the bottom line regardless of the menu selected.

If a flashing envelope symbol is displayed in the bottom line, it means there is no more storage space available on the SIM card for text messages. To be able to receive further messages, one or more saved messages must first be deleted.

To find out more, please refer to the section „DELETING A TEXT MESSAGE“ on page 78.

The arrival of a text message can also be indicated by an audible signal.

To find out more, please refer to the section „SWITCHING THE SMS SIGNAL TONE ON/OFF“ on page 88.

### Arrival of a vCard

The arrival of a vCard is indicated by a message in the bottom line as well as by an audible signal. The envelope symbol in the bottom line is not displayed.

### Reading a text message

1. Press the **PHONE** button.
2. Select **“Messages”**.
3. Open the relevant text message by selecting it.

**i** If you have received a text message with your mobile phone and cannot see it on the PCM display, this means that the text message was stored in your mobile phone’s memory and not on the SIM card. The PCM does not have access to the mobile phone memory.



In this case, please check whether the storage location for the text messages can be changed in your mobile phone’s settings.

Please consult the operating instructions for your mobile phone for this purpose.

### Replying to a text message

The following options are available to you:

- **“New text”**: The input menu is opened and new text can be entered.
- **“Attach reply”**: The input menu is opened and the original text of the message is shown in the text field. You can edit or add to the text as you want.
- **“Reply with YES”**: The input menu is opened and the original text of the message is shown in the text field. The reply “YES” is appended to the end of the text. You can edit or add to the text as you want.
- **“Reply with NO”**: The input menu is opened and the original text of the message is shown in the text field. The reply “NO” is appended to the end of the text. You can edit or add to the text as you want.
- **“Templates”**: A list of the message templates is opened and a template can be accepted or edited by selecting it.

### Creating a reply with new text

1. Press the **PHONE** button.
2. Select **“Messages”**.
3. Select the text message you want to reply to.
4. Select **“Reply”**.
5. Select **“New text”**.  
The input menu is opened.
6. Enter the text you want using the input menu.
7. Confirm your entry by selecting **“OK”**.  
The text input menu is closed and the input menu for the telephone number is opened. The number of the sender of the text message is already entered in the text field.
8. Select **“Send”** to send the message.

### Creating a text message with attached reply

1. Press the **PHONE** button.
2. Select **“Messages”**.
3. Select the text message you want to reply to.
4. Select **“Reply”**.
5. Select **“Attach reply”**.  
The input menu is opened. The reply is appended to the text received.
6. Edit the text as you want using the input menu and confirm by selecting **“OK”**.  
The text input menu is closed and the input menu for the telephone number is opened. The number of the sender of the text message is already entered in the text field.
7. Select **“Send”** to send the message.

### Replying to a text message with Yes or No

1. Press the **PHONE** button.
2. Select **“Messages”**.
3. Select the text message you want to reply to.
4. Select **“Reply”**.
5. Select **“Reply with YES”** or **“Reply with NO”**. The input menu is opened.
6. Edit the text as you want using the input menu and confirm by selecting **“OK”**. The text input menu is closed and the input menu for the telephone number is opened. The number of the sender of the text message is already entered in the text field.
7. Select **“Send”** to send the message.

### Replying to a text message using a text template

1. Press the **PHONE** button.
2. Select **“Messages”**.
3. Select the text message you want to reply to.
4. Select **“Reply”**.
5. Select **“Templates”**.
6. Select the template you want in the list that is displayed.
7. Select **“Edit template”** if applicable and make the changes you want in the text. Otherwise, select **“Use template”** and add any missing information.

8. Confirm your entry by selecting **“OK”**. The text input menu is closed and the input menu for the telephone number is opened. The number of the sender of the text message is already entered in the text field.
9. Select **“Send”** to send the message.

### Creating and sending a new text message

The following options are available to you for creating a text message:

- **“New text”**: The input menu is opened and new text can be entered.
- **“Last text”**: The input menu is opened and the text of the last message is shown in the text field. You can edit or add to this text as you want.
- **“Templates”**: A list of the message templates is opened and a template can be accepted or edited by selecting it.

### Creating a text message with new text

1. Press the **PHONE** button.
2. Select **“Messages”**.
3. Select the first list entry, **“New message”**, in the list that appears.
4. Select **“New text”**. The input menu is opened.
5. Enter the text you want using the input menu.

6. Confirm your entry by selecting **“OK”**. The text input menu is closed and the input menu for the telephone number is opened.
7. Enter the telephone number of the recipient. The following options are available to you:
  - Enter the digits in the input menu.
  - Select **“Phonebook”** to insert the number from the phonebook. Select the number you want to enter it in the input menu.
  - Select **“Previous calls”** to insert the number from the list. Select the number you want to enter it in the input menu.
  - Select **“Received calls”** to insert the number from the list. Select the number you want to enter it in the input menu.
8. Select **“Send”** to send the message.

### Editing and sending the text of the last message

1. Press the **PHONE** button.
2. Select **"Messages"**.
3. Select the first list entry, **"New message"**, in the list that appears.
4. Select **"Last text"**.
5. Edit the text displayed using the input menu and add to it if applicable.
6. Confirm your entry by selecting **"OK"**.  
The text input menu is closed and the input menu for the telephone number is opened.
7. Enter the telephone number of the recipient.  
The following options are available to you:
  - Enter the digits in the input menu.
  - Select **"Phonebook"** to insert the number from the phonebook.  
Select the number you want to enter it in the input menu.
  - Select **"Previous calls"** to insert the number from the list.  
Select the number you want to enter it in the input menu.
  - Select **"Received calls"** to insert the number from the list.  
Select the number you want to enter it in the input menu.
8. Select **"Send"** to send the message.

### Creating a text message using a text template

1. Press the **PHONE** button.
2. Select **"Messages"**.
3. Select the first list entry, **"New message"**, in the list that appears.
4. Select **"Templates"**.
5. Select the template you want in the list that is displayed.
6. Select **"Edit template"** if applicable and make the changes you want in the text.  
Otherwise, select **"Use template"** and add any missing information.
7. Confirm your entry by selecting **"OK"**.
8. Enter the telephone number of the recipient.  
The following options are available to you:
  - Enter the digits in the input menu.
  - Select **"Phonebook"** to insert the number from the phonebook.  
Select the number you want to enter it in the input menu.
  - Select **"Previous calls"** to insert the number from the list.  
Select the number you want to enter it in the input menu.
  - Select **"Received calls"** to insert the number from the list.  
Select the number you want to enter it in the input menu.
9. Select **"Send"** to send the message.

### Forwarding a text message

1. Press the **PHONE** button.
2. Select **"Messages"**.
3. Select the text message you want to forward.
4. Select **"Forward"**.  
The input menu is opened.
5. Edit the text message as you want and confirm by selecting **"OK"**.  
The text input menu is closed and the input menu for the telephone number is opened.
6. Enter the telephone number of the recipient.  
The following options are available to you:
  - Enter the digits in the input menu.
  - Select **"Phonebook"** to insert the number from the phonebook.  
Select the number you want to enter it in the input menu.
  - Select **"Previous calls"** to insert the number from the list.  
Select the number you want to enter it in the input menu.
  - Select **"Received calls"** to insert the number from the list.  
Select the number you want to enter it in the input menu.
7. Select **"Send"** to send the message.

## Deleting a text message

1. Press the **PHONE** button.
2. Select **“Messages”**.
3. Select the text message you want to delete.
4. Select **“Delete”**.  
You can then choose whether to delete the selected text message only or the entire list.

## Deleting the selected text message

5. Confirm the prompt that appears by selecting **“Yes”**.  
The selected text message is deleted.

## Deleting all text messages

5. Select **“Delete all”**.
6. Confirm the prompt that appears by selecting **“Delete all”** again.  
The text messages are deleted.

## Reading a vCard

1. Press the **PHONE** button.
2. Select **“Messages”**.
3. Open the relevant vCard by selecting it.
4. Select **“All details”** to view all of the details in the vCard.

## Accepting vCards

- i** If you save the vCard, the following data is accepted:
- the telephone numbers contained in the phonebook as well as
  - the addresses in the personal destination memory in the navigation menu.
- To find out more, please refer also to the section „PERSONAL DESTINATION MEMORY“ on page 131.

## Accepting a single vCard

1. Press the **PHONE** button.
2. Select **“Messages”**.
3. Open the relevant vCard by selecting it.
4. Select **“Accept”**.  
The details of the vCard are checked.
5. Confirm the acceptance of the valid addresses and telephone numbers by selecting **“OK”**.

## Accepting all vCards

1. Press the **PHONE** button.
2. Select **“Messages”**.
3. Open the relevant vCard by selecting it.

4. Select **“Accept all”**.
5. Select **“Accept all”** again to confirm the prompt that appears.  
The details of the vCards are checked and the valid addresses and telephone numbers are accepted.

## Editing vCard details

The addresses and telephone numbers contained on a vCard are listed in the vCard details. The following symbols are used:

- Details are correct and are accepted when the vCard is saved.
- Details are correct, but are not accepted when the vCard is saved. An appropriate message will be displayed.
- Details are not correct and can be changed or entered again if necessary.

The procedure for editing details is described below using address data as an example.

1. Press the **PHONE** button.
2. Select **"Messages"**.
3. Open the relevant vCard by selecting it.
4. Select **"Addresses"**.

The addresses are checked.

5. Select the address with the **"?"** symbol.  
The address is checked again. A search for similar addresses is performed.  
If similar addresses are found, these are listed after the check is completed.

#### Inserting and editing a similar address

6. Select a similar address from the list.
7. Select **"Edit"** if applicable and make the changes you want in the address input menu.
8. Select **"Accept"**.

**i** After selecting **"Accept"**, the address can no longer be edited.

#### Re-entering an address

6. Select **"Re-enter address"**.  
The address input menu is opened.

**i** If no similar addresses are found during checking, the address input menu opens automatically.

7. Enter the address you want.
8. Select **"Accept"**.

**i** After selecting **"Accept"**, the address can no longer be edited.

#### Discarding (deleting) vCards

##### Discarding a single vCard

1. Press the **PHONE** button.
2. Select **"Messages"**.
3. Open the relevant vCard by selecting it.
4. Select **"Discard"**.
5. Confirm the prompt by selecting **"Yes"**.  
The vCard is closed and deleted from the list of received messages.

##### Discarding all vCards

1. Press the **PHONE** button.
2. Select **"Messages"**.
3. Open the relevant vCard by selecting it.
4. Select **"Discard"**  
> **"Discard all"**.
5. Select **"Discard all"** again to confirm the prompt that appears.  
The vCards are closed and deleted from the list of received messages.

#### Numbers in text messages

If a text message contains telephone numbers or geographical coordinates, you can store these directly in the phonebook or list of personal destinations.

##### Calling telephone numbers from a text message

1. Press the **PHONE** button.
2. Select **"Messages"**.
3. Open the relevant text message by selecting it.

4. Select **"Extract number"**.

A list of the numbers contained in the text message is displayed.

5. Select the number you want in the list.
6. Select **"Add to number"** if applicable and enter the necessary digits.
7. Select **"Call number"**.  
The call is made.

##### Storing telephone numbers from a text message (only with the SIM card inserted)

1. Press the **PHONE** button.
2. Select **"Messages"**.
3. Open the relevant text message by selecting it.
4. Select **"Extract number"**.  
A list of the numbers contained in the text message is displayed.
5. Select the number you want in the list.
6. Select **"Store number"**.
7. Enter the details you want.  
To find out more, please refer to the section „PCM PHONEBOOK“ on page 69.

### Using geographical coordinates for route guidance

1. Press the **PHONE** button.
2. Select “**Messages**”.
3. Select “**Extract number**”.
4. Open the relevant geographical coordinate by selecting it.

The map view is displayed and the geographical coordinate is shown. To find out more, please refer also to the section „MAP“ on page 149.

5. Select “**Start route guidance**”.
- The route is calculated and route guidance starts.

### Storing geographical coordinates

1. Press the **PHONE** button.
2. Select “**Messages**”.
3. Select “**Extract number**”.
4. Open the relevant geographical coordinate by selecting it.

The map view is displayed and the geographical coordinate is shown. To find out more, please refer also to the section „MAP“ on page 149.

5. Select “**Store position**”.
- The input menu is opened and the coordinate is entered in the input field.
6. Enter the name of the geographical coordinate and confirm your entry by selecting “**OK**”.
- The geographical coordinate is stored in the list of personal destinations and the map view is displayed again.

### Displaying the complete text

1. Press the **PHONE** button.
2. Select “**Messages**”.
3. Open the relevant text message by selecting it.
4. Select “**Complete text**”.

The contents of the text message are shown across the entire display.

### Creating a template

Included in the list of templates are some blank entries that you can edit as you want.

1. Press the **PHONE** button.
  2. Select “**Messages**”.
  3. Select the first list entry, “**New message**”, in the list that appears.
  4. Select “**Templates**”.
  5. Select a blank template in the list that is displayed.
  6. Select “**Edit template**” and enter the text you want.
  7. Confirm your entry by selecting “**OK**”.
- The template is saved with the entered contents and will be subsequently displayed in the list.
8. Select “**Use template**” and add any missing information.
  9. Enter the telephone number as described in the section „CREATING A TEXT MESSAGE USING A TEXT TEMPLATE“ on page 77.
  10. Select “**Send**” to send the edited template.

## Telephone settings (PCM telephone)

### Switching the PCM telephone on/off

#### Switching the telephone on

1. Press the **PHONE** button.
2. Press the **OPTION** button or touch the tab of the same name in the header.
3. Select “**SET PHONE**”
  - > “**Telephone settings**”
  - > “**Switch on telephone**”.

The telephone is switched on.

#### Switching the telephone off

1. Press the **PHONE** button.
2. Press the **OPTION** button or touch the tab of the same name in the header.
3. Select “**SET PHONE**”
  - > “**Telephone settings**”
  - > “**Switch off telephone**”.

The telephone is switched off. All functions not dependent on the telephone are still available.



## Setting ringtones

### Setting the ringtone type

1. Press the **PHONE** button.
2. Press the **OPTION** button or touch the tab of the same name in the header.
3. Select “**SET PHONE**”
  - > “**Telephone settings**”
  - > “**Sound PHONE**”
  - > “**Ringtone type**”.A list of the available ringtones is displayed.
4. Set the ringtone you want by selecting it.  
The ringtone type is played after it is selected.
5. Change the volume of the ringtone type if necessary by turning the left rotary knob (⦿).  
The volume level set in this way is saved when you exit the menu.

**i** If the connected mobile phone supports the transfer of the ringtone via *Bluetooth*<sup>®</sup> (inband ringing), the Ringtone settings item is greyed out and the ringtone must be set on the mobile phone.

### Setting the ringtone volume

1. Press the **PHONE** button.
2. Press the **OPTION** button or touch the tab of the same name in the header.
3. Select “**SET PHONE**”
  - > “**Telephone settings**”
  - > “**Sound PHONE**”
  - > “**Ringtone volume**”.
4. Make the setting you want by turning the right rotary knob (⦿) or by selecting the two symbols (▲) and (▼).

### Selecting a network

You can set your PCM so that the network will be automatically or manually selected.

- i** This function is only available with the SIM card inserted or with a connection using the SIM Access Profile.
1. Press the **PHONE** button.
  2. Press the **OPTION** button or touch the tab of the same name in the header.
  3. Select “**SET PHONE**”
    - > “**Telephone settings**”
    - > “**Network selection**”.

4. Select one of the two available menu items:

#### – Automatic

The PCM automatically selects the mobile phone network of the SIM card that is logged in.

If this network is not found (e.g. when abroad), the network of a roaming partner is automatically selected.

#### – Manual

If you select **Manual**, the PCM telephone searches for the currently available networks, from which you can choose the mobile phone network you want to use.

**i** If a manually selected network is lost for more than 10 seconds, the system switches to automatic network selection.

## Displaying the IMEI

The IMEI (International **M**obile **E**quipment **I**dentify) is a serial number that permits unique identification of the hardware in mobile radio equipment. This number allows different network providers to block the telephone in the event of misuse.

1. Press the **PHONE** button.
2. Press the **OPTION** button or touch the tab of the same name in the header.
3. Select “**SET PHONE**”
  - > “**Telephone settings**”
  - > “**IMEI**”.The device number is displayed.

### Switching 3-way calling on/off

Problems may occur with 3-way calling on the PCM as these functions are not correctly supported by all mobile phones and telephone networks (in particular CDMA networks). It is recommended that 3-way calling be switched off in such cases in order to ensure reliable telephone operation.

- i** This function is only available if your mobile phone is connected to the PCM using the Hands-Free Profile.
1. Press the **PHONE** button.
  2. Press the **OPTION** button or touch the tab of the same name in the header.
  3. Select **"SET PHONE"**  
> **"Telephone settings"**.
  4. Select **"3-way calling"** to activate () or deactivate () the function.

### SIM settings

**i** This function is only available with the SIM card inserted or with a connection using the SIM Access Profile.

### Changing the PIN

This function allows you to change the PIN of your SIM card.

1. Press the **PHONE** button.
2. Press the **OPTION** button or touch the tab of the same name in the header.

3. Select **"SET PHONE"**  
> **"Telephone settings"**  
> **"SIM settings"**  
> **"Change PIN"**.  
The input menu for PIN entry is displayed. You must start by entering the current PIN.
4. Enter the current PIN by selecting the buttons on the keypad shown and confirm your entry by selecting **"OK"**.  
You are then prompted to enter the new PIN.
5. Enter the new PIN by selecting the buttons on the keypad shown and confirm your entry by selecting **"OK"**.  
You are then prompted to enter the new PIN a second time to confirm it.
6. Enter and confirm the new PIN again.  
If the two new PINs match you will see the message **"PIN has been changed"**.  
If the two entries do not match, you will be prompted to enter the new PIN again.

### Switching the PIN prompt on or off

The **"PIN prompt"** function allows you to switch the PIN prompt on and off. If the function is activated, you will be prompted for the PIN after you insert the SIM card. If the function is deactivated, the PIN prompt is deactivated.

1. Press the **PHONE** button.
2. Press the **OPTION** button or touch the tab of the same name in the header.
3. Select **"SET PHONE"**  
> **"Telephone settings"**  
> **"SIM settings"**.
4. Select **"PIN prompt"** to activate () or deactivate () the function.
5. Enter the PIN if necessary.  
The PIN prompt is switched on or off if the PIN is entered correctly.

**i** The PIN prompt cannot be switched off with some SIM cards.  
The PIN cannot be changed using the **"Change PIN"** function while the PIN prompt is switched off.

### Using a stored PIN

If the **"Last PIN"** function is activated, the PIN of the SIM card currently inserted is stored. The next time you insert the SIM card, the stored PIN is automatically used for the prompt.

1. Press the **PHONE** button.
2. Press the **OPTION** button or touch the tab of the same name in the header.
3. Select **"SET PHONE"**  
> **"Telephone settings"**  
> **"SIM settings"**.
4. Select **"Last PIN"** to activate (☑) or deactivate (☐) the function.

**i** If an incorrect PIN entry is registered after the SIM card is inserted, the last PIN will not be used any further. The input menu and the number of attempts still possible are displayed instead.

## Call settings (PCM telephone)

**i** This function is only available with the SIM card inserted or with a connection using the SIM Access Profile.

### Activating call forwarding

Call forwarding allows you to forward (divert) calls to another telephone number (e.g. to your answering machine).

When you first access the call forwarding system, the status of all call diversions in the network is automatically queried. The individual call forwarding functions cannot be selected during this time.

**i** Activating and deactivating call forwarding is not supported in all networks.

1. Press the **PHONE** button.
2. Press the **OPTION** button or touch the tab of the same name in the header.
3. Select **"SET PHONE"**  
> **"Call settings"**  
> **"Call forwarding"**.
4. Select one of the following settings for call forwarding:
  - **"Divert all"**  
activates call forwarding for all incoming calls.
  - **"Busy"**  
– activates call forwarding for calls that come in while you are on another call.  
To be able to activate call forwarding with the **"Busy"** setting, the **"Call waiting"** function must be switched off first.
  - **"No answer"**  
activates call forwarding for calls that you cannot or do not want to accept. The call is forwarded to the entered number after a certain time.
  - **"Cannot be reached"**  
– activates call forwarding for calls that come in while the telephone is switched off or is not ready to receive calls.
  - **"Cancel all"**  
deactivates all call diversions at once. The telephone numbers entered for the individual call diversions remain saved in the network and are displayed again the next time call forwarding is activated.

5. Select **"Switch on"**.  
The input menu is opened.
6. Enter the telephone number you want for the call diversion and confirm your entry by selecting **"OK"**.  
- or -  
Select **"Phonebook"**.  
After selecting **"Phonebook"** you can select a number from the phonebook. The call is then diverted to this number.
7. If you set the **"No answer"** call diversion type, you also need to set the delay after which the calls are to be diverted.  
Set the delay you want by selecting it in the list that appears.  
The relevant call diversion is then activated and the settings are shown on the display.

### Checking the status of the call diversion

1. Select the type of call forwarding you want.
2. Select **"Check status"**.  
The current status is then queried in the network and shown on the display after a few seconds.

## Deactivating call forwarding

1. Select the type of call forwarding you want.
2. Select **“Switch off”**.  
The corresponding call diversion is deactivated.

## Switching the “Call waiting” function on/off

If the **“Call waiting”** function is activated, an incoming call will be indicated during an active call.

The caller hears a ringing tone.

1. Press the **PHONE** button.
2. Press the **OPTION** button or touch the tab of the same name in the header.
3. Select **“SET PHONE”**  
> **“Call settings”**  
> **“Call waiting”**.
4. Select one of the following options:
  - Select **“Switch on”** to **activate** the function.
  - Select **“Switch off”** to **deactivate** the function.
  - Select **“Check status”** if the current status is unknown and should be queried in the network.

The current status will be displayed in the information area as soon as the query is answered.

## Switching the “Redial” function on/off

If the **“Redial”** function is activated, the telephone automatically redials a number that could not be reached because the line was busy.

1. Press the **PHONE** button.
2. Press the **OPTION** button or touch the tab of the same name in the header.
3. Select **“SET PHONE”**  
> **“Call settings”**.
4. Select **“Redial”** to activate () or deactivate () the function.

## Setting transfer of your own number

If the **“Send own number”** function is activated, your own telephone number will be sent to the other party.

1. Press the **PHONE** button.
2. Press the **OPTION** button or touch the tab of the same name in the header.
3. Select **“SET PHONE”**  
> **“Call settings”**  
> **“Send own number”**.

4. Select one of the following menu items:
  - **“Yes”** if you want to send your own number.
  - **“No”** if you want to suppress sending of your own number.
  - **“As network”** if you want to adopt the network operator or provider's setting.

**i** Depending on the network operator or provider, it may not be possible to switch off sending of your own number.

If you need to dial numbers with special characters (+, #, or \*), you must choose the **“As network”** setting.

## Setting automatic call answering





If the **“Auto. answer”** function is activated, the PCM automatically answers all incoming calls after the first ring. The active audio source is muted and the hands-free function automatically activated.

1. Press the **PHONE** button.
2. Press the **OPTION** button or touch the tab of the same name in the header.
3. Select **“SET PHONE”**  
> **“Call settings”**.
4. Select **“Auto. answer”** to activate () or deactivate () the function.

## Bluetooth® settings (PCM telephone)

### Authorised Bluetooth® devices

This function allows you to display a list of the Bluetooth® devices currently authorised to connect with your PCM. The list contains:

- mobile phones ,
- MP3 players ,
- headsets  as well as
- data devices .

### Displaying authorised Bluetooth® devices

1. Press the **PHONE** button.
2. Press the **OPTION** button or touch the tab of the same name in the header.
3. Select **“SET PHONE”**
  - > **“Bluetooth settings”**
  - > **“Device list”**.

**i** Devices that can be connected with the PCM using different profiles appear only once in the list. The symbol used always corresponds to the main application. Mobile phones that can also be used as MP3 players or data devices appear in this list with the telephone symbol.

### Connecting an authorised Bluetooth® device with the PCM

1. Open the list of authorised Bluetooth® devices.
2. Select the device you want in the list.
3. Select **“Connect”**.

**i** Data devices cannot be connected from the list of devices; they can only be connected by calling the appropriate application, for example when transferring a vCard.

### Disconnecting an authorised and connected Bluetooth® device from the PCM

1. Open the list of authorised Bluetooth® devices.
2. Select the device you want in the list.
3. Select **“Disconnect”**.

### Renaming an authorised Bluetooth® device

1. Open the list of authorised Bluetooth® devices.
2. Select the device you want in the list.
3. Select **“Rename”**.  
The input menu is opened.
4. Enter the name you want and confirm by selecting **“OK”**.  
The name of the device is now changed in the PCM.

### Deleting an authorised Bluetooth® device from the list

1. Open the list of authorised Bluetooth® devices.
2. Select the device you want in the list.
3. Select **“Delete”**.
4. Confirm the prompt that appears by selecting **“Yes”**.

### Deleting the list of authorised Bluetooth® devices

1. Open the list of authorised Bluetooth® devices.
2. Select any device in the list.
3. Select **“Delete”**.
4. Select **“Delete list”**.
5. Confirm the prompt that appears by selecting **“Delete all”**.

### Setting the profile of the authorised Bluetooth® device

With mobile phones that support both the SIM Access Profile and the Hands-Free Profile you can switch between the two profiles.

1. Open the list of authorised Bluetooth® devices.
2. Select any device in the list.
3. Select **“SIM access on”** or **“SIM access off”** depending on whether you want to activate or deactivate SIM card access.
4. Confirm the prompt that appears by selecting **“Yes”**.

**i** The switchover option is only available for mobile phones that support both profiles. This function is not available in all other cases.



### Displaying details for the authorised *Bluetooth*® device

1. Open the list of authorised *Bluetooth*® devices.
2. Select any device in the list.
3. Select “**Device details**”.  
The following information is displayed:
  - the device name,
  - the *Bluetooth*® address,
  - the connection quality as well as
  - the supported services.

### Adding a new *Bluetooth*® device

For the PCM to find your *Bluetooth*® device, please ensure that the *Bluetooth*® function on the device has been activated and set to “visible”. If you want to connect a mobile phone using the SIM Access Profile, external SIM mode needs to be activated on some devices. Further details can be found in the operating manual for your mobile phone.

1. Press the **PHONE** button.
2. Press the **OPTION** button or touch the tab of the same name in the header.
3. Select “**SET PHONE**”  
> “**Bluetooth settings**”  
> “**New device**”.  
A search is started and a list of the devices found is displayed.
4. Choose the device you want by selecting it in the list.  
A *Bluetooth*® code is displayed that you must enter in the corresponding *Bluetooth*® device. Once you have entered the code, successful authorisation of the device is shown on the display.
5. With mobile phones, the connection is automatically established by the PCM.

**i** With some mobile phones, the connection request by the PCM must be explicitly confirmed on the mobile phone. This may even have to be done a number of times in some cases, for example before transferring the phonebook.

To avoid this request, you can authorise the PCM in your mobile phone's list of devices. The connection will then be established automatically in the future, without the need for further checks.

Further details can be found in the operating manual for your mobile phone. It can take a few seconds for the *Bluetooth*® device to be authorised.

If the list of authorised *Bluetooth*® devices is full (max. 5 mobile phones), you must first delete a device from the list. An appropriate message will be displayed. To find out more, please refer to the section „DELETING AN AUTHORISED *BLUETOOTH*® DEVICE FROM THE LIST“ on page 85.

### Setting visibility

To ensure that your PCM can be connected to other devices via the *Bluetooth*® interface, it must be “visible” (=recognisable) for other devices during the connection operation.

To prevent further unwanted connection requests, you can deactivate visibility of the PCM after the connection operation.

1. Press the **PHONE** button.
2. Press the **OPTION** button or touch the tab of the same name in the header.
3. Select **"SET PHONE"**
  - > **"Bluetooth settings"**.
  - > Select **"PCM visible"** to activate (☑) or deactivate (☐) visibility of the PCM.

### Finding the cordless handset

This function starts the search for the cordless handset.

1. Press the **PHONE** button.
2. Press the **OPTION** button or touch the tab of the same name in the header.
3. Select **"SET PHONE"**
  - > **"Bluetooth settings"**
  - > **"Find handset"**.

The search is started. If the handset has been found and is not in the charging cradle, it will ring in confirmation and to help you locate it in the vehicle.

## Phonebook settings

### Setting the memory for the phonebook

You can set whether the phonebook entries on the SIM card, the phonebook entries in the telephone memory and/or the vCards stored in the PCM should be used for the display in the phonebook. This allows you to adapt the phonebook list of the PCM to your list in the mobile phone.

1. Press the **PHONE** button.
2. Press the **OPTION** button or touch the tab of the same name in the header.
3. Select **"SET PHONE"**
  - > **"Phonebook settings"**
  - > **"Phonebook memory"**.
4. Make the setting you want by selecting it.

**i** If the transfer of the phonebook data from your mobile phone to the PCM fails, it may be because your mobile phone is working with security mechanisms that affect transfer using the "Phone Book Access Profile" (PBAP). These security mechanisms require the PCM to be authorised on your mobile phone. As part of this, the telephone requests a "user ID" and a "password" from the PCM. In order for the PCM to gain access to the phonebook, it must log into the telephone.

Since the PCM uses the fixed parameters "UserID: PCM3" and "Pass: 0000" for this login, these parameters must be preset as permissible on your mobile phone.

▷ ▷ ▷

Please refer to the operating instructions for your mobile phone to find out whether these settings are required on your mobile phone and how to configure them.

### Setting sorting

You can adapt the sorting of the phonebook and call lists to the display on your mobile phone.

You have the following options for **sorting the phonebook**:

- **"Standard"**  
The phonebook is sorted by surname.
- **"Alternative"**  
The phonebook is sorted by first name.

You have the following options for **sorting the call lists**:

- **"Standard"**  
The call lists are sorted in the same order in which the entries were transferred from the mobile phone.
- **"Alternative"**  
The order of the entries transferred from the mobile phone is reversed. This option supports some mobile phones that transfer the oldest entries first.

1. Press the **PHONE** button.
2. Press the **OPTION** button or touch the tab of the same name in the header.
3. Select **"SET PHONE"**
  - > **"Phonebook settings"**
  - > **"Sorting"**.

## Setting sorting of the phonebook

4. Select **"Phonebook"**.
5. Select the sorting you want.

## Setting sorting of the call lists

4. Select **"Call lists"**.
5. Select the sorting you want.

## Setting automatic transfer of the phonebook

If the **"Auto update"** function is activated, the phonebook and the call lists of a mobile phone are transferred as soon as the PCM is connected to this mobile phone.

The data stored in the PCM is replaced by the current phonebook and current call lists from the mobile phone as soon as transfer is complete. If the **"Auto update"** function is deactivated, the data will no longer be updated.

**i** This function is not supported by all mobile phones.

1. Press the **PHONE** button.
2. Press the **OPTION** button or touch the tab of the same name in the header.
3. Select **"SET PHONE"**  
> **"Phonebook settings"**.
4. Select **"Auto update"** to activate () or deactivate () the function.

**i** Your phonebook data can then only be accessed when the corresponding mobile phone is connected to the PCM.

## Transferring the phonebook

This function transfers the phonebook and call lists of the connected mobile phone into the PCM again. The data stored in the PCM is replaced by the current phonebook and current lists from the mobile phone when transfer is complete.

1. Press the **PHONE** button.
2. Press the **OPTION** button or touch the tab of the same name in the header.
3. Select **"SET PHONE"**  
> **"Phonebook settings"**  
> **"Transfer phonebook"**.

## Deleting the phonebook

The copy of the phonebook transferred to the PCM can be deleted again. Your mobile phone's phonebook remains unchanged.

1. Press the **PHONE** button.
2. Press the **OPTION** button or touch the tab of the same name in the header.
3. Select **"SET PHONE"**  
> **"Phonebook settings"**  
> **"Delete phonebook"**.

## Settings for messages and data (PCM telephone)

**i** This function is only available with the SIM card inserted or with a connection using the SIM Access Profile.

### Changing the number of the SMS service centre

1. Press the **PHONE** button.
2. Press the **OPTION** button or touch the tab of the same name in the header.
3. Select **"SET PHONE"**  
> **"Messages/data"**  
> **"SMS service centre"**.  
The input menu for telephone numbers is opened. The current number is entered in the input field.
4. Enter the telephone number you want and confirm your entry by pressing **"OK"**.

### Switching the SMS signal tone on/off

The signal tone, which sounds when there is an incoming text message, can be switched on and off.

1. Press the **PHONE** button.
2. Press the **OPTION** button or touch the tab of the same name in the header.
3. Select **"SET PHONE"**  
> **"Messages/data"**.
4. Select **"SMS signal tone"** to activate () or deactivate () the function.



## Cordless handset

There is a cordless handset available for your PCM.

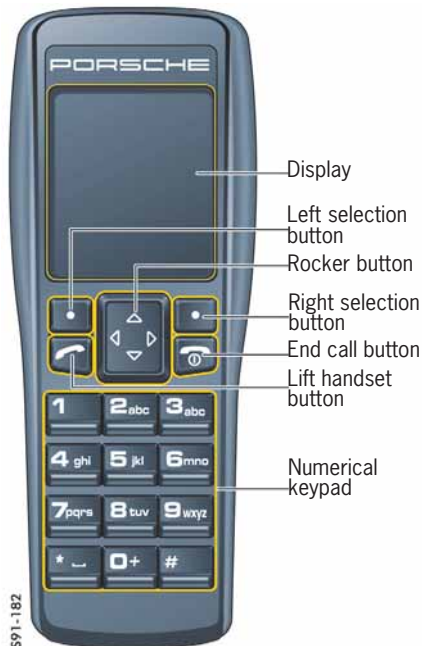

**i** Using a handset while driving is not permitted in all countries. Therefore, please observe the country-specific laws and regulations.

Once the internal telephone is switched on, the SIM card inserted and the PIN entered, most of the functions of the internal telephone will also be available on the handset. You can even enter the PIN on either the handset or the PCM.

**i** In order to increase battery life, the display is switched off after a certain time, provided the handset is not in the charging cradle.

**i** If a mobile phone is connected to the PCM using the Hands-Free Profile, the handset functions are not available.

### Switching the cordless handset on/off

- ▷ Press and hold the End call button for a few seconds to switch the handset on or off.

### Charging the cordless handset

- ▷ Place the handset in the charging cradle.

## General operation

Once you have entered the PIN, the telephone logs into a mobile phone network. On the display of the cordless handset you will see the network provider's name, the instantaneous signal strength, the *Bluetooth*<sup>®</sup> symbol, the charge level of the battery and two menu items.

You can select or open the menu items using the selection buttons beneath them. In many cases this brings you to a further menu.

You navigate within the individual menus using the rocker button that can be pressed at the top, bottom, left and right edges to move the highlighting in the respective direction.

Pressing the right selection button under the "Back" menu item brings you to the last menu opened or the next menu level up.

### Accepting a call

As soon as a call comes in, a menu is temporarily displayed on the display of the handset. If available, the telephone number is displayed together with the name of the caller (if an assignment to an entry stored in the phonebook is possible).

- ▷ Press the left selection button under the “**Accept**.” menu item.

- or -

- ▷ Press the Lift handset button on the handset. If the handset is not in the cradle, the ringtone of the PCM is accompanied by a further audio signal.

### Ending a call

- ▷ Press the right selection button under the “**End**” menu item.

- or -

- ▷ Press the End call button on the handset.

### Rejecting a call

- ▷ When there is a call incoming, press the right selection button under the “**Reject**” menu item.

### Dialling a number

1. Enter the individual digits in the telephone number one after the other using the keypad.
2. Press the left selection button under the “**Call**” menu item.  
The telephone call is established and the call menu is displayed.  
If the number dialled is busy, this will be indicated by a message on the display.

**i** Always enter the telephone number with the dialling code.

You can correct an incorrectly entered number by pressing the right selection button under the “**Delete**” menu item.

### Temporarily muting the handset microphone

You can mute the handset microphone during a phone call.

1. Press the left selection button under the “**Options**” menu item.
2. Select the “**Microphone mute**” menu item using the rocker button.
3. Press the left selection button under the “**Selection**” menu item to activate () or deactivate () the function.

### Establishing an additional call

You can establish a further connection with the “**New call**” function. You can either:

- enter a new telephone number or
- display and call entries from the phonebook, the list of previous calls or the list of received calls.

### Entering a new telephone number

1. Press the left selection button under the “**Options**” menu item.
2. Select the “**New call**” menu item using the rocker button.
3. Press the left selection button under the “**Selection**” menu item.
4. Enter the individual digits in the telephone number one after the other using the keypad.
5. Press the left selection button under the “**Call**” menu item.

### Calling an entry from one of the lists

1. Press the left selection button under the “**Options**” menu item.
2. Select the “**New call**” menu item using the rocker button.
3. Press the left selection button under the “**Selection**” menu item.
4. Select the list you want using the rocker button.
5. Press the left selection button under the “**Selection**” menu item.
6. Select the list item you want using the rocker button.
7. Press the left selection button under the “**Options**” menu item.
8. Select “**Call**” using the rocker button.
9. Press the left selection button under the “**Selection**” menu item.

The active call is retained if the second connection is established.

You can switch between the two calls or hold a conference call.

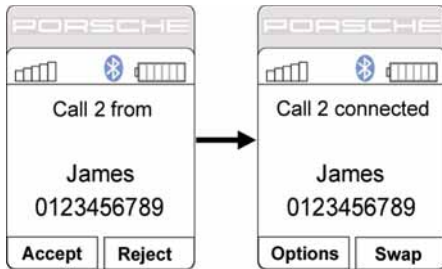

### Call waiting (swapping) and conference

The call waiting (swapping) and conference functions are only available if supported and unlocked by the network provider.

#### Call waiting (swapping)

While you are on a call, you may receive a call from someone else.

1. Press the left selection button under the “**Accept**.” menu item if you would like to accept the incoming call.
2. Press the right selection button under the “**Swap**” menu item to swap between the two calls.

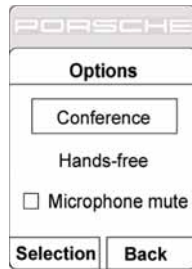

#### Conference

1. Press the left selection button under the “**Options**” menu item as soon as you are connected with two callers.
2. Select the “**Conference**” menu item using the rocker button.
3. Press the left selection button under the “**Selection**” menu item. The two calls are connected and the display shows that you are conferenced.
4. Press the right selection button under the “**End**” menu item to end the two calls.

### Phonebook

If your mobile phone is connected to the PCM using the SIM Access Profile, the data from the telephone memory and from the SIM card will be transferred. Memory entries may contain multiple telephone numbers for a name in this case.

#### Displaying the phonebook

- ▷ Press the right selection button under the “**Phonebook**” menu item.

- or -

- ▷ Press the rocker button upwards or downwards in the main menu of the handset.

#### Calling a phonebook entry

1. Open the phonebook.
2. Select the phonebook entry you want using the rocker button.
3. Press the left selection button under the “**Options**” menu item.
4. Select “**Call**” using the rocker button and press the left selection button under the “**Selection**” menu item.

- or -

Press the Lift handset button.

**i** You can use the “**Search**” option to search for specific entries in the phonebook. This is useful if there are many entries in your phonebook and you don't want to have to scroll through the entire list.

### Creating and storing a phonebook entry (only with the SIM card inserted)

1. Open the phonebook.
2. Press the left selection button under the “**Options**” menu item.
3. Select “**New entry**” using the rocker button.
4. Press the left selection button under the “**Selection**” menu item.
5. Enter the name for the new phonebook entry. The letters on the keypad are active while you are entering the name. This means you can enter the letters a, b and c, for example, by pressing the digit 2 repeatedly. The digits are reactivated while entering a telephone number. The input mode can be switched using the “#” button.
6. Press the left selection button under the “**OK**” menu item.
7. Enter the number for the new phonebook entry.
8. Press the left selection button under the “**OK**” menu item.  
The data is stored on the SIM card. An appropriate message is displayed if there is no more space on the SIM card.

### Editing a phonebook entry (only with the SIM card inserted)

1. Open the phonebook.
2. Select the phonebook entry you want using the rocker button.
3. Press the left selection button under the “**Options**” menu item.
4. Select “**Edit entry**” using the rocker button.
5. Press the left selection button under the “**Selection**” menu item.
6. Edit the name of the phonebook entry as you want.
7. Press the left selection button under the “**OK**” menu item.
8. Edit the telephone number of the phonebook entry as you want.
9. Press the left selection button under the “**OK**” menu item.  
The phonebook entry is stored.

### Deleting a phonebook entry

1. Open the phonebook.
2. Select the phonebook entry you want using the rocker button.
3. Press the left selection button under the “**Options**” menu item.
4. Select “**Delete entry**” using the rocker button.
5. Press the left selection button under the “**Selection**” menu item.
6. Press the left selection button under the “**Yes**” menu item to confirm the prompt.

### Text messages (SMS)

Some menu items are not available before the SMS list is loaded.

### Reading a text message

1. Press the left selection button under the “**Menu**” menu item.
2. Select the “**Messages**” menu item using the rocker button.
3. Press the left selection button under the “**Selection**” menu item.
4. Select the “**Input**” menu item using the rocker button.
5. Press the left selection button under the “**Selection**” menu item.  
The stored messages are listed. Small symbols (open or closed envelopes) indicate whether or not the message has already been read.
6. Select the message you want using the rocker button.
7. Press the left selection button under the “**Options**” menu item.
8. Select the “**Read**” menu item using the rocker button.
9. Press the left selection button under the “**Selection**” menu item.  
The text message is opened.

### Replying to/forwarding a text message

1. Press the left selection button under the “**Menu**” menu item.
2. Select the “**Messages**” menu item using the rocker button.
3. Press the left selection button under the “**Selection**” menu item.
4. Select the “**Input**” menu item using the rocker button.
5. Press the left selection button under the “**Selection**” menu item.
6. Select the message you want using the rocker button.
7. Press the left selection button under the “**Options**” menu item.
8. Using the rocker button, select “**Reply**” or “**Forward**” depending on the function you want to use.
9. Press the left selection button under the “**Selection**” menu item.
10. Enter the text using the letters on the keypad.
11. Press the left selection button under the “**Options**” menu item.
12. Select the “**Send**” menu item using the rocker button.
13. Press the left selection button under the “**Selection**” menu item.  
The telephone number of the text message sender is displayed.
14. Press the left selection button under the “**OK**” menu item.  
The text message is sent.

### Creating and sending a new text message

1. Press the left selection button under the “**Menu**” menu item.
  2. Select the “**Messages**” menu item using the rocker button.
  3. Press the left selection button under the “**Selection**” menu item.
  4. Select the “**Compose**” menu item using the rocker button.
  5. Press the left selection button under the “**Selection**” menu item.
  6. Enter the text using the letters on the keypad. The letters on the keypad are active while you are entering the name. This means you can enter the letters a, b and c, for example, by pressing the digit 2 repeatedly. The digits are reactivated while entering a telephone number.  
Use the # button to switch the input mode between uppercase, lowercase and digits.
- i** If you want to insert the text from a template, select the “**Discard template**” menu item, highlight the template you want using the rocker button and insert it by pressing the left selection button under the “**Selection**” menu item.

7. Press the left selection button under the “**Options**” menu item.
  8. Select the “**Send**” menu item using the rocker button.
  9. Press the left selection button under the “**Selection**” menu item.
  10. Enter the telephone number.
  11. Press the left selection button under the “**OK**” menu item.  
The text message is sent.
- i** Please proceed as follows if you want to send the message to a telephone number from the phonebook or from one of the two lists (“**Previous calls**” and “**Received calls**”):
12. Press the left selection button under the “**Search**” menu item.
  13. Select the list you want (“**Phonebook**”, “**Previous calls**” and “**Received calls**”) using the rocker button.
  14. Select the entry you want.
  15. Press the left selection button under the “**Selection**” menu item.  
The number is inserted in the text field.
  16. Press the left selection button under the “**OK**” menu item.  
The text message is sent.

## Deleting a text message

1. Press the left selection button under the **“Menu”** menu item.
2. Select the **“Messages”** menu item using the rocker button.
3. Press the left selection button under the **“Selection”** menu item.
4. Press the left selection button under the **“Options”** menu item.
5. Select the **“Input”** menu item using the rocker button.
6. Press the left selection button under the **“Selection”** menu item.
7. Select the message you want using the rocker button.
8. Press the left selection button under the **“Options”** menu item.
9. Using the rocker button, select the **“Delete”** menu item if you only want to delete the selected text message.  
**Or:**  
Using the rocker button, select the **“Delete all”** menu item if you want to delete all saved text messages.
10. Press the left selection button under the **“Yes”** menu item to delete the message.

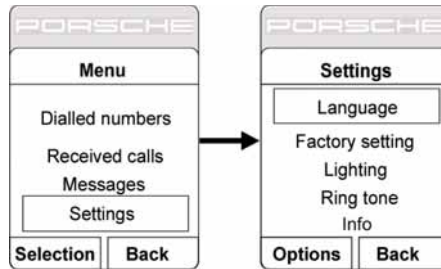

## Settings

1. Press the left selection button under the **“Menu”** menu item.
2. Select the **“Settings”** menu item using the rocker button.
3. Press the left selection button under the **“Selection”** menu item.  
You then have the following options:
  - **“Language”**:  
Under this menu item you can set the menu language you want for the handset.
  - **“Factory setting”**:  
Under this menu item you can reset the handset to the factory settings.

- **“Lighting”**:  
Under this menu item you can enter a value for the illumination of the handset display.
  - **“Ring tone”**:  
Under this menu item you can set the volume and profile (ascending volume) for the handset ringtone.
  - **“Info”**:  
Under this menu item you will find details of the hardware and software used in your handset.
4. Select the menu item you want.
  5. Press the left selection button under the **“Options”** menu item.
  6. Select the setting you want.
  7. Press the left selection button under the **“OK”** menu item.

Displaying traffic messages (TMC) .....	96
Displaying sections of the route.....	98
Displaying information about the location .....	98
Displaying detailed information about the active audio source.....	98



In the **INFO** menu you will find various general information such as the current audio source, the date and time and the signal strength for your telephone network.

You also have the option to call up more detailed information about the traffic situation, your current location, the individual sections in your route or the current audio source.

## Displaying traffic messages (TMC)

Various FM radio stations transmit traffic messages in addition to their radio programme (TMC messages = **T**raffic **M**essage **C**hannel). The PCM evaluates and displays this information.

In some countries (e.g. Great Britain and France), the TMC information transmitted can vary significantly depending on the local radio station tuned into.









The navigation system takes these traffic messages into consideration during dynamic route calculation.

**i** The broadcasting stations are responsible for the quality of the traffic messages. We therefore cannot accept any liability for the completeness and correctness of the information.



Austria: The location and event code was made available by ASFINAG and BMVIT.

You can display the current traffic messages in a list. If the route guidance component of your navigation system is active, the traffic messages on your route are displayed in a separate list. The following types of traffic messages are differentiated:

-  Objects on the road
-  Objects on a section of the current, personal route
-  Accident
-  Accident on a section of the current, personal route
-  Roadworks
-  Roadworks on a section of the current, personal route
-  Slow moving traffic or traffic jam
-  Slow moving traffic or traffic jam on a section of the current, personal route





Accident hazard



Accident hazard on a section of the current, personal route



Route section blocked



Section of the current, personal route blocked



Information



Information concerning a section of the current, personal route

1. Press the **INFO** button.
2. Select **"Traffic messages"**.  
If route guidance is active, the current traffic messages on your route are listed.
3. Select **"All traffic messages"** if necessary.  
A list containing all current traffic messages is opened. The traffic messages on your route are highlighted in orange in this list.







4. Select a traffic message from the list to call up more detailed information on it.  
You then see a map section showing the route section in question as well as the full text of the traffic message.



5. You can change the map scale if necessary by selecting the two symbols and . You can scroll through the messages by selecting the symbols and or by turning the right rotary knob.  
In the case of very long traffic messages, you can scroll to the previous or next page by selecting the symbols and .

## Displaying sections of the route

If you have started the route guidance component of your navigation system, a list containing all sections of your route will be displayed. This function is not available during trace recording of off-road navigation.

1. Press the **INFO** button.
2. Select **"Route list"**.  
The sections of your route are listed and displayed.  
The section you are currently driving on is at the very top of this list and the final destination at the very bottom.
3. Select the section you want for a more detailed view.  
You then see a map section showing the route section in question.
4. You can change the map scale if necessary by selecting the two symbols  and .  
You can scroll through the various sections by selecting the symbols  and  or by turning  the right rotary knob.
5. If you wish to detour around this section of your route, select **"Detour"**.  
To find out more about setting detours, please refer to the section „SETTING A DETOUR“ on page 136.

## Displaying information about the location

This function displays the precise data for your current location.

If the route guidance component of your navigation system is active, the next route section is also displayed.



1. Press the **INFO** button.
2. Select **"Location info"**.  
The information about your current location and its environs is displayed.

## Displaying detailed information about the active audio source

This function displays information about the audio source currently active. The menu display is adapted to the active audio source.

The procedure for calling up the detailed information during radio mode is described here as an example.

1. Press the **INFO** button.
2. Select **"Details FM"**.  
The available information is displayed.

- i** If the display of the radio text has been switched off in the **TUNER** menu, it will not be displayed here either. To find out more, please refer to the section „SWITCHING RDS RADIO TEXT ON/OFF“ on page 22.
- In TV mode with digital reception, the station, the start/end time, the name of the current programme, the progress bar (showing how far along the programme is) and the genre are displayed. Further details about the programme can also be displayed in a list. If the text extends beyond the page, you can scroll through the text using the symbols  and  or by turning the right rotary knob . The availability and amount of additional information transmitted varies from station to station. With analogue reception, only the name of the station and the channel on which the programme is being broadcast are displayed.

Trip data display .....	100	Viewing the list of stored trips.....	111
Setting the display group .....	100	Managing the logbook lists .....	111
Setting the contents of the		Deleting trips.....	112
personal display .....	100	Transferring the logbook data.....	112
Resetting trip data .....	101	Bluetooth® settings .....	113
Hybrid display		The Sport display .....	115
(not available for sports cars).....	101	Starting recording.....	115
Hybrid energy flow.....	101	Stopping recording .....	116
Hybrid zero emission .....	102	Continuing recording.....	116
ParkAssist .....	102	Ending a lap/starting a new lap.....	116
Deactivating ParkAssist.....	103	Timing the interval .....	116
Switching the ParkAssist display on/off .....	103	Evaluating a recording .....	117
Closing the ParkAssist display .....	104	Renaming a recording.....	117
Rear view camera		Deleting recordings .....	117
(not available for sports cars).....	104	Deleting a lap .....	118
Switching the		Storing a lap as the reference lap .....	118
rear view camera display on/off.....	105	Defining the reference lap .....	118
Closing the rear view camera display .....	105	Resetting the defined reference lap .....	118
Switching grid lines for the		Renaming the reference lap .....	118
rear view camera on/off.....	106	Deleting the reference lap .....	119
Parking with the rear view camera display ..	106	Deleting all laps .....	119
Picture settings for the rear view camera ...	107	Setting the display of additional data .....	119
Combining ParkAssist and the		Transferring data .....	119
rear view camera display .....	107	Bluetooth® settings .....	120
Logbook .....	108	Extended memory .....	121
Activating/deactivating the logbook .....	108	Setting light options .....	121
Activating/deactivating the		Setting wiper options .....	122
logbook reminder .....	108	Setting reversing options .....	123
Setting the standard trip for the logbook ....	108	Setting comfort options.....	123
Editing data from the current trip .....	109	Choosing the options for setting	
Continuing recording from the last trip .....	110	the air conditioning .....	124
Storing a refuelling stop .....	110		



## Trip data display

The CAR menu provides you with a variety of useful trip data such as the trip time, distance covered, average speed and average fuel consumption.

The following display groups are differentiated depending on the vehicle's equipment:

- **Total trip data**  
The trip data is totalled continuously until re-set. The trip data is retained even after the vehicle has been stationary (with the ignition key removed) for relatively long periods.
- **Trip data since ...**  
The trip data is automatically reset after the car has been parked for 2 hours (with the ignition key removed).

### - Personal trip data

The trip data can be individually compiled in four data fields.

### - Hybrid energy flow

(not available for sports cars)

The hybrid energy flow shows the instantaneous energy flow with animated arrows. The display shows the combustion engine, the battery, the hybrid module and the wheels.

### - Hybrid Zero Emission

(not available for sports cars)

The hybrid zero emission shows the statistical trip information for hybrid mode.

The number of displays available to you is shown between the two arrow symbols ◀ and ▶.

## Setting the display group

- ▷ Touch the ◀ and ▶ symbols.
- or -
- ▷ Turn the right rotary knob (⦿).

## Setting the contents of the personal display

You can configure the contents of the individual data fields for the “Personal trip data” display yourself. You can choose between general information such as date, time or outside temperature as well as various data fields from the navigation area such as arrival times, average speeds or consumption and a number of vehicle parameters.

1. Press the **CAR** button.
2. Press the **OPTION** button or touch the tab of the same name in the header.
3. Select “**SET CAR**”  
> “**Personal settings**”.
4. Select the data field to be changed.  
A list containing multiple menu items is opened.
5. Select the menu item you want.  
The chosen menu item is inserted in the corresponding data field.

**i** If you fill a data field with the “**Distance to next petrol station**” menu item, you can start a route calculation to this petrol station by touching the symbol on the display.  
If you select “**Start route guidance**”, route guidance to this petrol station is started.

## Resetting trip data

By pressing the **Reset** button field for at least 1 second, you can reset the following trip data:

- the “**Total trip data**” display group,
- the “**Trip data since ...**” display group and
- the “**Hybrid Zero Emission**” display.

1. Press the **CAR** button.
2. Set the display to be reset by selecting the symbols ◀ and ▶.
3. Select **Reset** for at least 1 second.  
The trip data in the corresponding display is reset.

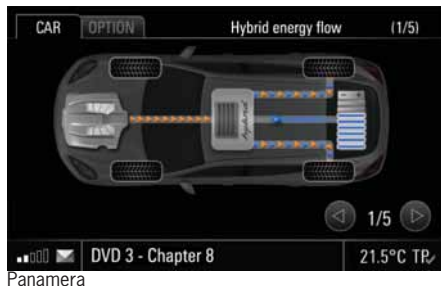

Panamera

## Hybrid display (not available for sports cars)

The hybrid display is divided into the hybrid energy flow and hybrid zero emission.

**i** A detailed description of the hybrid mode for your vehicle can be found in the owner's manual.

### Hybrid energy flow

The hybrid energy flow shows the instantaneous energy flow with animated arrows. The display shows the combustion engine, the battery, the hybrid module and the wheels.

The battery charge state is indicated by the number of blue charge bars.

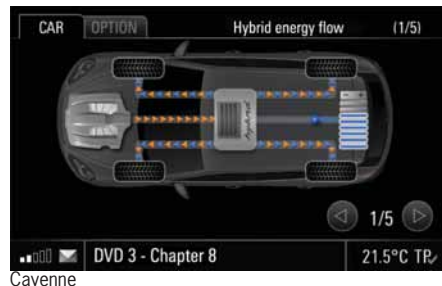

Cayenne

The various energy flow options are indicated by the following symbols:

- **Orange triangles**  
The combustion engine is running. The energy created as a result is used to power the vehicle while driving. The energy is used to charge the battery when the vehicle is stationary.
- **Blue triangles**  
The battery energy is used to power the vehicle.
- **Blue and orange triangles**  
Both the battery energy and the running combustion engine power the vehicle.
- **Green triangles**  
The vehicle coasts due to a downhill gradient or the vehicle is decelerated by means of the engine brake. The energy created as a result is used to charge the battery.
- **Blue arrow from the hybrid module to the battery**  
The battery is charged.
- **Blue arrow from the battery to the hybrid module**  
The battery energy is supplied to other consumers.

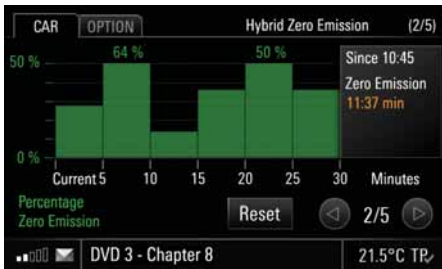

## Hybrid zero emission

The hybrid zero emission shows statistical information for your trip. It contains:

- Graphical representation of the engine-off times in the form of a chart. The stop duration of the combustion engine is displayed for five-minute intervals as a percentage.
- Display of the duration of the engine-off times in minutes and seconds (total).

The display of the duration of the engine-off times refers to the trip data for the “**Trip data since ...**” display group. It is reset automatically after the car has been parked for two hours (with the ignition key removed).



Panamera

## ParkAssist

ParkAssist indicates the distance between the vehicle and an object visually and acoustically for the driver when parking and manoeuvring.

The visual parking aid of ParkAssist is shown on the PCM display. Obstacles located in front of and behind the vehicle are indicated using different coloured fields. These fields show the contour of obstacles as well as their distance from the vehicle.

ParkAssist is activated automatically when the ignition is turned on up to a speed of approx. 15 km/h (approx. 9.5 mph).



Cayenne

**i** To find out more, please refer also to the corresponding chapter in the owner's manual.

### **WARNING**

**Accident hazard. Even with ParkAssist, responsibility for parking and for assessing obstacles lies with the driver.**

**A continuous tone sounds when there is a risk of collision.**

- ▷ Make sure that there are no people, animals or obstacles within the manoeuvring area.
- ▷ If the continuous tone sounds, do not move the vehicle any closer to an obstacle.



Sports cars

Coloured fields are used to show obstacles and their distance from the vehicle.

Display of distances:

Field colour	Distance <b>in front of</b> vehicle	Distance <b>behind</b> vehicle
green	< 120 cm (approx. 47 in.)	< 180 cm (approx. 71 in.)
yellow	< 80 cm (approx. 31 in.)	< 80 cm (approx. 31 in.)
red	< 40 cm (approx. 16 in.)	< 45 cm (approx. 18 in.)
red with continuous tone	< 30 cm (approx. 12 in.)	< 30 cm (approx. 12 in.)

**i** If ParkAssist detects a trailer, no distance information is displayed for the rear of the vehicle.



Panamera

S91-026



Cayenne

UA1-167

### Deactivating ParkAssist

ParkAssist can be deactivated using the **A** button in the roof control console. The indicator light in the button is lit when ParkAssist is deactivated. In this case there is **no** automatic display on the PCM. Manual activation of the display is not possible either. To find out more, please refer also to the section „SWITCHING THE DISPLAY ON MANUALLY“ on page 104.

- ▷ Press the **A** button to deactivate or reactivate ParkAssist.

### Switching the ParkAssist display on/off

#### Switching the automatic display on/off

If the function is activated, the visual parking aid is shown on the PCM under the following conditions:

- when reverse gear is engaged,
- if a roll backwards is detected,
- if the distance at the front is less than 80 cm.

1. Press the **CAR** button.
2. Press the **OPTION** button or touch the tab of the same name in the header.
3. Select **“SET CAR”**  
> **“SET parking”**.
4. Select **“ParkAssist”** to activate () or deactivate () the function.

9C1-112



Sports cars

### Switching the display on manually

1. Press the **CAR** button.
2. Press the **OPTION** button or touch the tab of the same name in the header.
3. Select “**ParkAssist**”.

The visual parking aid is shown on the PCM display.

- i** When the display is active, you can switch immediately to the “**SET parking**” menu by pressing the **OPTION** button.

### Closing the ParkAssist display

The display is closed again as soon as you:

- disengage reverse gear (after 30 seconds or a speed of > 15 km/h (approx. 9.5 mph)),
- operate the electric parking brake,
- move the Porsche Doppelkupplung (PDK) gear selector into the **P** position,
- press one of the main menu buttons or
- press the Back button .

- i** In the four last cases you can press the **CAR** button to return to the display.

S91-166



Panamera

### Rear view camera (not available for sports cars)

The rear view camera serves to monitor the area behind the vehicle during parking manoeuvres. The image from the rear view camera is shown on the PCM display.

You have the option of displaying grid lines in the rear view camera image. These grid lines change according to the current position of the front wheels. They therefore show you where the current steering wheel turn will bring you.





1UA1-146

**WARNING**

**Injury hazard. The rear view camera only serves to assist the driver. It does not replace looking over your shoulder. The display of objects captured by the rear view camera is distorted. The camera view does not cover the complete area behind the vehicle.**

▷ Continue to pay attention to the complete area around the vehicle.

**Switching the rear view camera display on/off**

**Switching automatic rear view camera display on/off**

If the function is activated, the rear view camera image appears on the PCM display automatically when reverse gear is engaged or when the rolling back of the vehicle is detected.

1. Press the **CAR** button.
2. Press the **OPTION** button or touch the tab of the same name in the header.
3. Select **"SET CAR"** > **"SET parking"**.
4. Select **"Rear view camera"** to activate (☑) or deactivate (☐) the function.

**Switching the rear view camera display on manually**

1. Press the **CAR** button.
2. Press the **OPTION** button or touch the tab of the same name in the header.
3. Select **"SET CAR"** > **"SET parking"** > **"Show RVC image"**.  
The image is shown on the PCM display.

**Closing the rear view camera display**

The rear view camera display is closed again as soon as you:

- disengage reverse gear (after 30 seconds or a speed of > 15 km/h (approx. 9.5 mph)),
- press one of the main menu buttons,
- press the Back button ,
- operate the electric parking brake or
- move the Porsche Doppelkupplung (PDK) gear selector into the **P** position.

**i** In the four last cases you can press the **CAR** button to return to the display.

Cayenne

**i** The TV sound is suppressed while the image from the rear view camera is shown on the display. Audio source (FM, AM, CD/DVD, AUX and AUX BT) sound output continues uninterrupted.

There is no rear view camera display when the parking brake is activated.

**i** Voice control is not available while the image is displayed.

**i** Always keep the rear view camera free from dirt, ice and snow, as these can have an adverse effect on the camera image.

## Switching grid lines for the rear view camera on/off

**i** No grid lines are displayed in the following situations:

- forward driving,
  - manual activation of the rear view camera display,
  - open tailgate,
  - trailer detected,
  - uncalibrated system
- or
- steering angle sensor error.

In the last four cases, a message text appears in the bottom line.

In the last two cases, please visit a Porsche workshop.

1. Press the **CAR** button.
2. Press the **OPTION** button or touch the tab of the same name in the header.
3. Select **“SET CAR”**  
> **“SET parking”**.
4. Select **“RVC grid lines”** to activate () or deactivate () the function.



### Parking with the rear view camera display

1. Engage reverse gear.
2. Turn the steering wheel so that the grid lines guide you into the parking space as accurately as possible.
3. Drive backwards carefully until the edges of the blue parking aid are parallel to the parking space.
4. Turn the steering wheel to straighten up while the vehicle is stationary. Drive until the end of the lower edge of the blue parking aid is positioned at the end of the parking space.

**i** If the ground is uneven, the display of the grid lines may differ from the actual lane.

### **⚠** WARNING

**Accident hazard. If there are obstacles visible on the display there is a risk of collision.**



- ▷ Make sure that there are no people, animals or obstacles within the manoeuvring area.

**Accident hazard. If the ground is uneven, the road is slippery or the vehicle is on an incline (e.g. curb, hill) the actual lane may differ from the precalculated grid lines.**



- ▷ Continue to pay attention to the complete area around the vehicle.

## Picture settings for the rear view camera





### Setting the Brightness

1. Press the **CAR** button.
2. Press the **OPTION** button or touch the tab of the same name in the header.
3. Select **"SET CAR"**
  - > **"SET parking"**
  - > **"RVC picture param."**
  - > **"Brightness"**.
4. Make the setting you want by selecting the two symbols  and  or by turning  the right rotary knob.
5. If the rear view camera is automatically activated, select **"Back to RVC"** to cancel the picture configuration and return to the camera image.

### Setting the Contrast

1. Press the **CAR** button.
2. Press the **OPTION** button or touch the tab of the same name in the header.
3. Select **"SET CAR"**
  - > **"SET parking"**
  - > **"RVC picture param."**
  - > **"Contrast"**.
4. Make the setting you want by selecting the two symbols  and  or by turning  the right rotary knob.
5. If the rear view camera is automatically activated, select **"Back to RVC"** to cancel the picture configuration and return to the camera image.

### Setting the Colour

1. Press the **CAR** button.
  2. Press the **OPTION** button or touch the tab of the same name in the header.
  3. Select **"SET CAR"**
    - > **"SET parking"**
    - > **"RVC picture param."**
    - > **"Colour"**.
  4. Make the setting you want by selecting the two symbols  and  or by turning  the right rotary knob.
  5. If the rear view camera is automatically activated, select **"Back to RVC"** to cancel the picture configuration and return to the camera image.
-  When the display is active, you can switch immediately to the **"SET parking"** menu by pressing the **OPTION** button.



### Combining ParkAssist and the rear view camera display

You can combine the ParkAssist and rear view camera display. In this case you can show and hide ParkAssist by touching the vehicle on the display.

ParkAssist is shown on either the left or right edge of the screen depending on the steering angle.

## Logbook

The logbook automatically records all the trips made by the vehicle and stores them together with a variety of relevant information. This includes:

- the type of use (business trip, work trip or private trip),
- the date and time,
- the start address,
- the destination address,
- the distance as well as
- the odometer reading at the start and destination locations.

Recording of a trip is started and ended automatically when the logbook is activated. It begins as soon as the vehicle key is inserted.

When the vehicle key is removed, recording stops and the information is stored.

If a distance of less than 100 metres (approx. 330 feet) is driven, the route is not recorded and is added to the next trip.

**i** The trips are recorded even if the PCM has been switched off with the left rotary knob. The logbook can record and store up to 1,500 trips. The stored data can be transferred to a Bluetooth device or a USB device.

You can view and edit the logbook data on a PC using the supplied software.

**i** The logbook must be activated before it can be used.

### Activating/deactivating the logbook

1. Press the **CAR** button.
2. Press the **OPTION** button or touch the tab of the same name in the header.
3. Select “**SET CAR**”  
> “**SET logbook**”.
4. Select “**Logbook active**” to activate () or deactivate () the function.

### Activating/deactivating the logbook reminder

If you have activated the “**Reminder**” function, the logbook menu appears for several seconds each time the PCM starts up.

1. Press the **CAR** button.
2. Press the **OPTION** button or touch the tab of the same name in the header.
3. Select “**SET CAR**”  
> “**SET logbook**”.
4. Select “**Reminder**” to activate () or deactivate () the function.

### Setting the standard trip for the logbook

The “**Standard trip**” function allows you to choose the trip type to be set as standard at the start of a journey.

The following trip types are available:

- “**Business trip**”,
- “**Work trip**”,
- “**Private trip**” as well as
- “**Last trip**”.

The “**Last trip**” trip type is only available if at least one trip has been recorded.

1. Press the **CAR** button.
2. Press the **OPTION** button or touch the tab of the same name in the header.
3. Select “**SET CAR**”  
> “**SET logbook**”  
> “**Standard trip**”.
4. Select the trip type you want.

## Editing data from the current trip

You can change the different pieces of data registered by the logbook during recording of a trip as many times as you want during the trip.

### Changing the trip type

1. Press the **CAR** button.
2. Press the **OPTION** button or touch the tab of the same name in the header.
3. Select “**Logbook**”  
> “**Current trip**”.
4. Select the trip type you want.

### Changing the driver

1. Press the **CAR** button.
2. Press the **OPTION** button or touch the tab of the same name in the header.
3. Select “**Logbook**”  
> “**Current trip**”  
> “**Edit trip**”  
> “**Driver**”.  
A list of all the drivers created so far is opened.  
If a driver has been assigned a specific key, this is also shown in the list.
4. Insert the driver you want by selecting him or her.

### Creating a new driver

1. Press the **CAR** button.
2. Press the **OPTION** button or touch the tab of the same name in the header.
3. Select “**Logbook**”  
> “**Current trip**”  
> “**Edit trip**”  
> “**Driver**”  
“**New driver**”.  
The input menu is opened.
4. Enter the name of the new driver and confirm by selecting “**OK**”.

**i** If the current trip is not a **Business trip**, but rather a **Work trip** or **Private trip**, the only fields available to you are “**Driver**” and “**Remarks**”.

### Changing the trip destination

1. Press the **CAR** button.
2. Press the **OPTION** button or touch the tab of the same name in the header.
3. Select “**Logbook**”  
> “**Current trip**”  
> “**Edit trip**”  
> “**Trip destination**”.  
A list of all the destinations created so far is opened.
4. Insert the trip destination you want by selecting it.

### Creating a new trip destination

1. Press the **CAR** button.
2. Press the **OPTION** button or touch the tab of the same name in the header.
3. Select “**Logbook**”  
> “**Current trip**”  
> “**Edit trip**”  
> “**Trip destination**”  
“**New trip destination**”.  
The input menu is opened.
4. Enter the new trip destination you want and confirm by selecting “**OK**”.

### Changing the trip purpose

1. Press the **CAR** button.
2. Press the **OPTION** button or touch the tab of the same name in the header.
3. Select “**Logbook**”  
> “**Current trip**”  
> “**Edit trip**”  
> “**Trip purpose**”.  
A list of the trip purposes already created is opened.
4. Insert the trip purpose you want by selecting it.

### Creating a new trip purpose

1. Press the **CAR** button.
2. Press the **OPTION** button or touch the tab of the same name in the header.
3. Select “**Logbook**”
  - > “**Current trip**”
  - > “**Edit trip**”
  - > “**Trip purpose**”
  - > “**New trip purpose**”.The input menu is opened.
4. Enter the new trip purpose you want and confirm by selecting “**OK**”.

### Changing the contact person

1. Press the **CAR** button.
2. Press the **OPTION** button or touch the tab of the same name in the header.
3. Select “**Logbook**”
  - > “**Current trip**”
  - > “**Edit trip**”
  - > “**Contact person**”.A list of the contact persons already created is opened.
4. Insert the contact person you want by selecting him or her.

### Creating a new contact person

1. Press the **CAR** button.
2. Press the **OPTION** button or touch the tab of the same name in the header.
3. Select “**Logbook**”
  - > “**Current trip**”
  - > “**Edit trip**”
  - > “**Contact person**”
  - > “**New contact person**”.The input menu is opened.
4. Enter the new contact person and confirm by selecting “**OK**”.

### Changing the remarks

1. Press the **CAR** button.
2. Press the **OPTION** button or touch the tab of the same name in the header.
3. Select “**Logbook**”
  - > “**Current trip**”
  - > “**Edit trip**”
  - > “**Remarks**”.The input menu is opened.
4. Enter the text you want and confirm by selecting “**OK**”.

### Continuing recording from the last trip

If a trip has been completed with the logbook activated, the previous trip can be continued the next time a trip is started.

1. Press the **CAR** button.
  2. Press the **OPTION** button or touch the tab of the same name in the header.
  3. Select “**Logbook**”
    - > “**Continue trip**”.The data from the last recorded trip is displayed.  
You are then asked once more whether you want to continue the last trip.
  4. Confirm the question by selecting “**Yes**”.
- Recording of the last trip is continued.

### Storing a refuelling stop

If you want to store a refuelling stop in the trip currently being recorded, you can do so by selecting “**Refuelling stop**”.

1. Press the **CAR** button.
  2. Press the **OPTION** button or touch the tab of the same name in the header.
  3. Select “**Logbook**”
    - > “**Refuelling stop**”.The question “**Store refuelling stop?**” appears.
  4. Confirm the question by selecting “**Yes**”.
- The refuelling stop is stored.

## Viewing the list of stored trips

1. Press the **CAR** button.
2. Press the **OPTION** button or touch the tab of the same name in the header.
3. Select “**Logbook**”  
> “**Trip list**”.  
The trip list is displayed.  
If a recording is currently in progress, it is displayed at the top of the list.
4. Select a trip to open a detailed view of it.  
You can scroll between the detailed views for the individual trips by selecting the symbols ◀ and ▶.

**i** You can switch between scrolling in the detailed view and scrolling in the list by pressing the right rotary knob →.

## Managing the logbook lists

In addition to the lists of stored trips, lists for the **Driver**, the **Trip purpose**, the **Trip destination** and the **Contact person** are also created in the logbook.

### Creating a new list entry

You can create a new entry by selecting the first entry in any list (e.g. “**New driver**”).

1. Press the **CAR** button.
2. Press the **OPTION** button or touch the tab of the same name in the header.

3. Select “**SET CAR**”  
> “**SET logbook**”  
> “**Manage lists**”.
4. Select the list you want.
5. Select the top list entry.  
The input menu is opened.
6. Enter the name you want and confirm by selecting “**OK**”.  
The entry is then created in the list.

### Renaming a list entry

You can rename the individual list entries as many times as you want.

1. Press the **CAR** button.
2. Press the **OPTION** button or touch the tab of the same name in the header.
3. Select “**SET CAR**”  
> “**SET logbook**”  
> “**Manage lists**”.
4. Select the list you want.
5. Select the list entry you want.
6. Select “**Rename**”.  
The input menu is opened.
7. Enter the name you want and confirm by selecting “**OK**”.  
The name is now changed.

### Deleting a list entry

You can delete each individual entry in a list.

1. Press the **CAR** button.
2. Press the **OPTION** button or touch the tab of the same name in the header.
3. Select “**SET CAR**”  
> “**SET logbook**”  
> “**Manage lists**”.
4. Select the list you want.
5. Select the list entry you want.
6. Select “**Delete**”.
7. Answer the question displayed by selecting “**Yes**”.  
The list entry is deleted.

### Assigning the current key to a driver in the driver list

You can assign the key currently being used to a driver in the list.

If this key is used again when the logbook is activated, the logbook “recognises” the driver and automatically records his or her name.

1. Press the **CAR** button.
2. Press the **OPTION** button or touch the tab of the same name in the header.
3. Select **"SET CAR"**  
> **"SET logbook"**  
> **"Manage lists"**.
4. Select the **"Driver"** list.
5. Select the driver you want.
6. Select **"Assign key"**.  
If the key is already assigned to another driver, you are informed of this at this point. The existing key assignment is discarded once you confirm this prompt.
7. Confirm the prompt by selecting **"Yes"**.  
The key is assigned to the driver. The assignment is now also shown in the list.

#### Deleting an existing key assignment

You can delete an existing key assignment again.

1. Press the **CAR** button.
2. Press the **OPTION** button or touch the tab of the same name in the header.
3. Select **"SET CAR"**  
> **"SET logbook"**  
> **"Manage lists"**.
4. Select the **"Driver"** list.
5. Select the driver you want.
6. Select **"Delete key"**.
7. Confirm the prompt by selecting **"Yes"**.  
The assignment is deleted again.

#### Deleting trips

You can either delete the trips already transferred from your logbook or all recorded trips.

1. Press the **CAR** button.
2. Press the **OPTION** button or touch the tab of the same name in the header.
3. Select **"SET CAR"**  
> **"SET logbook"**  
> **"Delete trips"**.

#### Deleting trips already transferred

4. Select **"Transferred trips"**.
5. Confirm by selecting **"Yes"**.  
All trips already transferred are deleted.

#### Deleting all trips

4. Select **"All trips"**.
5. Confirm by selecting **"Yes"**.  
All trips are deleted.

#### Transferring the logbook data

Depending on how your PCM is equipped, you can transfer stored data via either the *Bluetooth*<sup>®</sup> interface or the USB interface. The data is not deleted during this process.

- i** It is recommended that you transfer and back up the data at regular intervals.

- i** The name of the file where the transferred logbook data is stored is made up of the abbreviation **"FB"**, the date (YYMMDD) and the extension **".bin"**.

Please note that multiple logbooks transferred on the same day will overwrite each other without notice.

1. Press the **CAR** button.
2. Press the **OPTION** button or touch the tab of the same name in the header.
3. Select **"Logbook"**  
> **"Transfer data"**.

#### Transferring data via the USB interface

- i** You can only access the **"To USB"** transmission mode if there is a USB memory stick attached to the USB interface. To find out more about the permissible USB memory media, please refer to the section „NOTES ON THE MEDIA SUPPORTED“ on page 40.

4. Select **"To USB"**.

The data is transferred, provided there is a storage medium without write protection and with sufficient free memory connected.

Otherwise you are notified of the problem with the data transfer by means of an error message.



## Transferring data via the Bluetooth interface

**i** Please note that the connection between both devices must be activated for data transfer using *Bluetooth*<sup>®</sup>. To find out how to activate this connection, please refer to the section „SWITCHING BLUETOOTH<sup>®</sup> ON“ on page 113.

4. Select “**To Bluetooth**”.

5. A list of all known devices that may be used for a transfer of logbook data is displayed. If the device you want is not there, you can search for further devices. To do this, press “**New device**” (see also the section „ADDING A NEW BLUETOOTH<sup>®</sup> DEVICE“ on page 113).

As soon as the search is complete, a list containing the devices found is displayed.

6. Select the device you want in the list.  
The data is transferred.

**i** You may first need to authorise a new device. To find out more, please refer to the section „ADDING A NEW BLUETOOTH<sup>®</sup> DEVICE“ on page 113.

## *Bluetooth*<sup>®</sup> settings

### Calling up *Bluetooth*<sup>®</sup> settings

1. Press the **CAR** button.
2. Press the **OPTION** button or touch the tab of the same name in the header.
3. Select “**Logbook**”  
> “**Transfer data**”  
> “**Bluetooth settings**”.

### Switching *Bluetooth*<sup>®</sup> on

- ▷ Select “**Switch on Bluetooth**” in the *Bluetooth*<sup>®</sup> settings.

### Switching *Bluetooth*<sup>®</sup> off

- ▷ Select “**Switch off Bluetooth**” in the *Bluetooth*<sup>®</sup> settings.

### Adding a new *Bluetooth*<sup>®</sup> device

For the PCM to find your *Bluetooth*<sup>®</sup> device, please ensure that the *Bluetooth*<sup>®</sup> function on the device has been activated and set to “visible”.

1. Select “**New data device**” in the *Bluetooth*<sup>®</sup> settings.  
A search is started and a list of the devices found is displayed.
2. Choose the device you want by selecting it in the list.  
A *Bluetooth*<sup>®</sup> code is displayed that you must enter in the corresponding *Bluetooth*<sup>®</sup> device. Once you have entered the code, successful authorisation of the device is shown on the display.

## Establishing a connection from an external *Bluetooth*<sup>®</sup> device

To find out more, please refer to the section „ESTABLISHING A CONNECTION FROM AN EXTERNAL BLUETOOTH<sup>®</sup> DEVICE“ on page 62.

### Setting visibility

To find out more, please refer to the section „SETTING VISIBILITY“ on page 63.

### Authorised *Bluetooth*<sup>®</sup> devices

This function allows you to display a list of the *Bluetooth*<sup>®</sup> devices currently authorised to connect with your PCM. The list contains all authorised data devices .

### Displaying authorised *Bluetooth*<sup>®</sup> devices

- ▷ Select “**List of data devices**” in the *Bluetooth*<sup>®</sup> settings.

### Connecting an authorised *Bluetooth*<sup>®</sup> device with the PCM

**i** Data devices cannot be connected from the list of devices; they can only be connected by calling the appropriate application, for example when transferring the logbook.

### Renaming an authorised *Bluetooth*<sup>®</sup> device

1. Select “**List of data devices**” in the *Bluetooth*<sup>®</sup> settings.
2. Select the device you want in the list.
3. Select “**Rename**”.  
The input menu is opened.
4. Enter the name you want and confirm by selecting “**OK**”.  
The name of the device is now changed in the PCM.

### Deleting an authorised *Bluetooth*<sup>®</sup> device from the list

1. Select “**List of data devices**” in the *Bluetooth*<sup>®</sup> settings.
2. Select the device you want in the list.
3. Select “**Delete**”.
4. Confirm the prompt that appears by selecting “**Yes**”.

### Deleting the list of authorised *Bluetooth*<sup>®</sup> devices

1. Select “**List of data devices**” in the *Bluetooth*<sup>®</sup> settings.
2. Select any device in the list.
3. Select “**Delete**”.
4. Select “**Delete list**”.
5. Confirm the prompt that appears by selecting “**Delete all**”.

### Displaying details for the authorised *Bluetooth*<sup>®</sup> device

1. Select “**List of data devices**” in the *Bluetooth*<sup>®</sup> settings.
2. Select any device in the list.
3. Select “**Device details**”.  
The following information is displayed:
  - the device name,
  - the *Bluetooth*<sup>®</sup> address as well as
  - the supported services.

## The Sport display

The Sport display is part of the Sport Chrono Package Plus that also includes a stopwatch and buttons for dynamic driving settings (Sport mode). The combination of the stopwatch and the PCM allows lap data to be recorded and evaluated.

The time is recorded by the stopwatch operated using the CHRONO on-board computer menu in the instrument cluster.

Refer also to the section “Chrono” in the vehicle operating manual.

The graphical display as well as the storage and evaluation of the recorded lap times and the associated lap lengths is performed by the PCM.

The following information can be recorded and displayed for each driven lap:

- the route,
- the fastest lap time and in comparison the current lap time,
- a comparison of the current lap and the fastest lap so far,
- the portion of the lap already covered and
- the distance or number of laps possible with the remaining fuel.

The functions of the Sport display can be used for any route (e.g. journey to work), not just laps.

Any recorded lap/distance can be defined as a reference lap. This then forms the basis for comparing further laps/routes and recorded times. Laps/distances whose length differs by more than 15 percent (longer or shorter) from the reference distance will be marked in the evaluation.



### Starting recording

As soon as the stopwatch in the CHRONO on-board computer menu is started, recording begins along with recording of the route, which is shown on the display.

You can see the following in the display:

- a white line representing the reference lap,
- a destination flag marking the start of recording,
- a yellow line representing your current lap as well as
- an orange dot representing the position of the vehicle on the route.

**i** The route is only recorded when the display of “Additional data” is activated in the “SET sport display”. To find out more, please refer to the section „SETTING THE DISPLAY OF ADDITIONAL DATA“ on page 119.



The first lap of the recording is used as a reference lap if none has already been loaded. This is needed to display the circle diagram in the lap details as well as to display the remaining laps left in the tank.

**i** A maximum of 63 laps can be stored for each recording.

### Lap information

The route is displayed when the Sport display is called up. You can then switch between the route and the lap details by selecting the symbols and or by turning the rotary knob . This information consists of:

- the time of the fastest lap,
- the current lap time,
- information on the remaining tank range (in remaining laps and as a distance) as well as
- the remaining memory available.

The left half of the display shows a circle diagram. It indicates the distance covered in relation to a complete lap.

The circle diagram assumes different colours depending on whether the current lap is faster, as fast as or slower than the previous fastest lap:

- green - current lap is faster,
- yellow - current lap is as fast,
- red - current lap is slower.

The number in the centre of the coloured circle indicates the current lap.

**i** If you have not loaded any reference laps, the first lap recorded will be used as a reference lap.

Neither the remaining number of laps nor the fastest lap time is displayed while the first lap is being recorded. The circle diagram is not filled yet either.

### Available memory is full

If the available memory is full, a message to this effect appears in the display. The lap details will continue to be displayed, however the lap during which the message appears as well as any further laps will no longer be recorded.

A maximum of 8 hours can be recorded.

### Stopping recording

Selecting “**Stop**” in the on-board computer menu stops the stopwatch and therefore the recording in progress.

The recorded data is stored.

### Continuing recording

As soon as the stopwatch is restarted in the on-board computer menu with “**Res.**”, the Sport display appears again.

This is only possible, however, if you do not reset the stopwatch in the on-board computer menu beforehand.

### Ending a lap/starting a new lap

Selecting “**Round**” in the on-board computer menu ends one lap and starts a new lap.

### Timing the interval

Selecting “**Int.**” in the on-board computer menu and then pressing the stalk forwards displays the interval for several seconds.

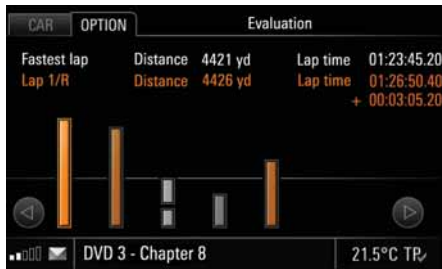

### Evaluating a recording

1. Press the **CAR** button.
2. Press the **OPTION** button or touch the tab of the same name in the header.
3. Select **"Sport display"** > **"Recordings"**.  
A list of the stored recordings is opened. Reference laps are indicated in the list using the **R** symbol.
4. Select the recording you want.
5. Select **"Evaluation"**.

The individual laps are shown side-by-side as bars in the evaluation that appears. The height of these bars represents the corresponding lap time. The higher the bar, the longer the lap time.

You can scroll forward and backward in the evaluation by:

- ▷ Touching the symbols **◀** and **▶** on the display.
- or -
- ▷ Turning the right rotary knob **⌚**.

### Reference lap

If you did not define a reference lap when recording started, the first lap is treated as the reference lap and is shown as **"Lap 1/R"**.

### Fastest lap

The laps are generally displayed in orange. The only exception to this is the fastest lap, which is shown in white.

### Interrupted lap

If a lap is shown with a broken bar, this means that either the driving was interrupted or the vehicle was stationary for a time. Parking periods result when the ignition is switched off.

### Implausible (divergent) laps are shown in grey.

Implausible laps are shown in grey. Laps are regarded as implausible if their distance deviates more than 15% from the distance of the reference lap.

### Renaming a recording

1. Press the **CAR** button.
2. Press the **OPTION** button or touch the tab of the same name in the header.
3. Select **"Sport display"** > **"Recordings"**.  
A list of the stored recordings is opened. Reference laps are indicated in the list using the **R** symbol.
4. Select the recording you want.
5. Select **"Rename"**.  
The input menu is opened.
6. Enter the name you want and confirm by selecting **"OK"**.  
The name is now changed.

### Deleting recordings

You cannot delete a recording while the **"Res."** function can be selected in the on-board computer menu. In order to be able to delete a recording, you must first reset the stopwatch in the on-board computer menu.

1. Press the **CAR** button.
2. Press the **OPTION** button or touch the tab of the same name in the header.
3. Select **"Sport display"** > **"Recordings"**.  
A list of the stored recordings is opened. Reference laps are indicated in the list using the **R** symbol.

### Deleting recordings individually

4. Select the recording you want.
5. Select **“Delete”**.
6. Confirm the prompt by selecting **“Yes”**.  
The recording is deleted.

### Deleting all recordings

4. Select a recording.
5. Select **“Delete”**.  
> **“Delete list”**.
6. Confirm the prompt by selecting **“Delete all”**.

### Deleting a lap

You cannot delete the last lap using the **“Delete lap”** menu item while the **“Res.”** function can still be selected in the on-board computer menu. In this case, the stopwatch in the on-board computer must be reset and the lap deleted afterwards. To find out more, please refer to the section „DELETING RECORDINGS“ on page 117.

1. Press the **CAR** button.
2. Press the **OPTION** button or touch the tab of the same name in the header.
3. Select **“Sport display”**  
> **“Recordings”**.  
A list of the stored recordings is opened.
4. Select the recording you want.
5. Select **“Evaluation”**.
6. Select the lap you want from the evaluation.
7. Select **“Delete lap”**.  
The lap is deleted from the recording.

### Storing a lap as the reference lap

1. Press the **CAR** button.
2. Press the **OPTION** button or touch the tab of the same name in the header.
3. Select **“Sport display”**  
> **“Recordings”**.  
A list of the stored recordings is opened.
4. Select the recording you want.
5. Select **“Evaluation”**.
6. Select the lap you want from the evaluation.
7. Select **“Store reference”**.  
The lap is stored as the reference lap.

### Defining the reference lap

If no reference lap is defined in advance, the first lap in a recording is automatically used as the reference lap.

Furthermore, any lap already recorded can be defined as the reference lap for the next recording.

1. Press the **CAR** button.
2. Press the **OPTION** button or touch the tab of the same name in the header.
3. Select **“Sport display”**  
> **“Recordings”**.  
A list of the stored recordings is opened.  
The reference laps are indicated in the list using the  symbol.
4. Select the reference lap you want.
5. Select **“Set reference”**.  
The chosen reference lap is used for future recordings.

### Resetting the defined reference lap

1. Press the **CAR** button.
2. Press the **OPTION** button or touch the tab of the same name in the header.
3. Select **“Sport display”**  
> **“Reset reference”**.  
The previously defined reference lap is reset. If no new reference lap is defined, the first lap is used again as the reference lap for any further recordings.

### Renaming the reference lap

1. Press the **CAR** button.
2. Press the **OPTION** button or touch the tab of the same name in the header.
3. Select **“Sport display”**  
> **“Recordings”**.  
A list of the stored recordings is opened.
4. Select the reference lap you want.
5. Select **“Rename”**.  
The input menu is opened.
6. Enter the name you want and confirm by selecting **“OK”**.  
The name of the reference lap is now changed.

## Deleting the reference lap

1. Press the **CAR** button.
2. Press the **OPTION** button or touch the tab of the same name in the header.
3. Select **“Sport display”**  
> **“Recordings”**.  
A list of the stored recordings is opened.
4. Select the reference lap you want.
5. Select **“Delete”**.
6. Confirm by selecting **“Yes”**.  
The recording is now deleted.

## Deleting all laps

This function can be used to delete all recordings and reference laps.

1. Press the **CAR** button.
2. Press the **OPTION** button or touch the tab of the same name in the header.
3. Select **“SET CAR”**  
> **“SET sport display”**.
4. **“Delete trips”**.
5. Confirm the prompt that appears by selecting **“Delete all”**.

## Setting the display of additional data

1. Press the **CAR** button.
2. Select **OPTION**.
3. Select **“SET CAR”**  
> **“SET sport display”**.
4. Select **“Additional data”** to activate () or deactivate () the function.

## Transferring data

- i** We recommend that you transfer and back up the data at regular intervals.
1. Press the **CAR** button.
  2. Select **OPTION**.
  3. Select **“Sport display”**  
> **“Transfer data”**.  
A list of the stored recordings is opened.
  4. Select the recording you want or the **“All”** list entry.

## Transferring data via the USB interface

- i** You can only access the **“To USB”** transmission mode if there is a USB memory stick attached to the USB interface. To find out more about the permissible USB memory media, please refer to the section **„NOTES ON THE MEDIA SUPPORTED“** on page 40.  
A directory called **“SportChrono”** is created on the storage medium during data transfer.
5. Select **“To USB”**.  
The data is transferred, provided there is a storage medium without write protection and with sufficient free memory connected. Otherwise you are notified of the problem with the data transfer by means of an error message.

## Transferring data via the **Bluetooth®** interface

- i** Please note that the connection between both devices must be activated for data transfer using **Bluetooth®**. To find out how to activate this connection, please refer to the section **„SWITCHING BLUETOOTH® ON“** on page 120.
5. Select **“To Bluetooth”**.
  6. A list of all known devices that may be used for a transfer of data is displayed. If the device you want is not there, you can search for further devices. To do this, press **“New device”** (see also the section **„ADDING A NEW BLUETOOTH® DEVICE“** on page 120).  
As soon as the search is complete, a list containing the devices found is displayed.
  7. Select the device you want.
- i** You may first need to authorise a new device. To find out more, please refer to the section **„ADDING A NEW BLUETOOTH® DEVICE“** on page 120.

## Bluetooth® settings

### Calling up Bluetooth® settings

1. Press the **CAR** button.
2. Select **OPTION**.
3. Select **“Sport display”**
  - > **“Transfer data”**
  - > **“Bluetooth settings”**.

### Switching Bluetooth® on

- ▷ Select **“Switch on Bluetooth”** in the *Bluetooth®* settings.

### Switching Bluetooth® off

- ▷ Select **“Switch off Bluetooth”** in the *Bluetooth®* settings.

### Adding a new Bluetooth® device

For the PCM to find your *Bluetooth®* device, please ensure that the *Bluetooth®* function on the device has been activated and set to “visible”.

1. Select **“New data device”** in the *Bluetooth®* settings.

A search is started and a list of the devices found is displayed.
2. Choose the device you want by selecting it in the list.

A *Bluetooth®* code is displayed that you must enter in the corresponding *Bluetooth®* device. Once you have entered the code, successful authorisation of the device is shown on the display.

### Establishing a connection from an external Bluetooth® device

To find out more, please refer to the section „ESTABLISHING A CONNECTION FROM AN EXTERNAL BLUETOOTH® DEVICE“ on page 62.

### Setting visibility

To find out more, please refer to the section „SETTING VISIBILITY“ on page 63.

### Authorised Bluetooth® devices

This function allows you to display a list of the *Bluetooth®* devices currently authorised to connect with your PCM. The list contains all authorised data devices .

### Displaying authorised Bluetooth® devices

- ▷ Select **“List of data devices”** in the *Bluetooth®* settings.

### Connecting an authorised Bluetooth® device with the PCM

 Data devices cannot be connected from the list of devices; they can only be connected by calling the appropriate application, for example when transferring the data from the Sport display.

### Renaming an authorised Bluetooth® device

1. Select **“List of data devices”** in the *Bluetooth®* settings.
2. Select the device you want in the list.

3. Select **“Rename”**.

The input menu is opened.

4. Enter the name you want and confirm by selecting **“OK”**.

The name of the device is now changed in the PCM.

### Deleting an authorised Bluetooth® device from the list

1. Select **“List of data devices”** in the *Bluetooth®* settings.
2. Select the device you want in the list.
3. Select **“Delete”**.
4. Confirm the prompt that appears by selecting **“Yes”**.

### Deleting the list of authorised Bluetooth® devices

1. Select **“List of data devices”** in the *Bluetooth®* settings.
2. Select any device in the list.
3. Select **“Delete”**.
4. Select **“Delete list”**.
5. Confirm the prompt that appears by selecting **“Delete all”**.

### Displaying details for the authorised Bluetooth® device

1. Select **“List of data devices”** in the *Bluetooth®* settings.
2. Select any device in the list.
3. Select **“Device details”**.

The following information is displayed:

  - the device name,
  - the *Bluetooth®* address as well as
  - the supported services.



## Extended memory

In the PCM menu you have the option to store various settings for up to three of your vehicle's ignition keys and two of your vehicle's memory buttons. Both driver-related settings from the instrument cluster as well as PCM settings are stored in this process.

The following PCM settings are stored:

- the personal data fields of the trip data in the **CAR** main menu,
- the stations stored on the station buttons of the various preset memories in radio mode,
- the sound settings for the various audio sources,
- the volume settings for the various audio sources,
- settings for the map view as well as
- the settings for voice control.

The vehicle-dependent settings are described in the following sections.



To find out more about the extended memory, please refer also to the corresponding chapter in the owner's manual.

**i** The range of vehicle settings available in the PCM depends on the vehicle type and the equipment installed.

## Setting light options

### Setting the fade-out time for the exterior lights of the vehicle

You can set a fade-out time of between 10 and 120 seconds for your vehicle's exterior lights.

1. Press the **CAR** button.
2. Press the **OPTION** button or touch the tab of the same name in the header.
3. Select **"SET CAR"**
  - > **"Vehicle functions"**
  - > **"Light & visibility"**
  - > **"Exterior lights"**
  - > **"Fade-out time"**.
4. Set the time period you want by touching the two symbols  and  or by turning  the right rotary knob.

The setting is immediately applied.

The **"Fade-out time"** setting also changes the illumination duration when unlocking the vehicle.

To find out more about this, please refer to the chapter "Welcome home function" in the owner's manual.

### Setting the alignment for the low beam

You can set the alignment of the low beam headlights for driving on the right or left.

You can only change this function when the vehicle is stationary.

1. Press the **CAR** button.
2. Press the **OPTION** button or touch the tab of the same name in the header.
3. Select **"SET CAR"**
  - > **"Vehicle functions"**
  - > **"Light & visibility"**
  - > **"Exterior lights"**
  - > **"L/R driving"**.
4. Select **"Standard"** to adapt the headlights to the normal direction of traffic in the delivery country.  
- or -
4. Select **"Inverted"** to adapt the headlights to the other direction of traffic.

### Setting the daytime running lights

If the **"Daytime light"** function is active () , the lights will always be switched on when the engine is running. This applies regardless of the light switch setting.

The illumination of the instruments and switches is still switched on and off via the light switch, regardless of the **"Daytime light"** setting.

This function is only available in countries where daytime running lights are not mandatory.

1. Press the **CAR** button.
2. Press the **OPTION** button or touch the tab of the same name in the header.
3. Select **"SET CAR"**
  - > **"Vehicle functions"**
  - > **"Light & visibility"**
  - > **"Exterior lights"**.
4. Select **"Daytime light"** to activate (☑) or deactivate (☐) the function.

### Setting the orientation light

The orientation lighting include the lights in the area of the roof console, the inner door handles and the storage compartments.

You can set the intensity of the orientation light on a scale from 0 to 10.

1. Press the **CAR** button.
2. Press the **OPTION** button or touch the tab of the same name in the header.
3. Select **"SET CAR"**
  - > **"Vehicle functions"**
  - > **"Light & visibility"**
  - > **"Interior lights"**
  - > **"Ambient light"**.
4. Set the intensity you want by touching the two symbols (▲) and (▼) or by turning (⦿) the right rotary knob.  
The setting is immediately applied.

### Setting the fade-out time for the interior lights of the vehicle

You can set a fade-out time of between 0 and 300 seconds for your vehicle's interior lights.

1. Press the **CAR** button.
2. Press the **OPTION** button or touch the tab of the same name in the header.
3. Select **"SET CAR"**
  - > **"Vehicle functions"**
  - > **"Light & visibility"**
  - > **"Interior lights"**
  - > **"Fade-out time"**.
4. Set the time period you want by touching the two symbols (▲) and (▼) or by turning (⦿) the right rotary knob.  
The setting is immediately applied.

### Setting wiper options

You can choose whether you want to switch on your vehicle's windscreen wipers yourself or whether they should be controlled automatically.

### Setting activation of the rain sensor

1. Press the **CAR** button.
2. Press the **OPTION** button or touch the tab of the same name in the header.

3. Select **"SET CAR"**
  - > **"Vehicle functions"**
  - > **"Light & visibility"**
  - > **"Wiper"**
  - > **"Rain sensor"**.
4. Select **"Automatic"** if the rain sensor is to be permanently active as soon as the wiper switch is set to intermittent mode.  
- or -
4. Select **"Manual"** if the rain sensor is to be started manually.

### Setting activation of the rear wiper

1. Press the **CAR** button.
2. Press the **OPTION** button or touch the tab of the same name in the header.
3. Select **"SET CAR"**
  - > **"Vehicle functions"**
  - > **"Light & visibility"**
  - > **"Wiper"**
  - > **"Rear wiper"**.
4. Select **"Automatic"** if the rear wiper is to be switched on automatically. This happens as soon as reverse gear is engaged and the front wiper has been active during the previous 40 seconds.  
- or -
4. Select **"Manual"** if the rear wiper is to be started manually.

## Setting reversing options

### Setting lowering of the right exterior mirror

You can set whether the right exterior mirror is to be lowered automatically and the direction indicator is to be operated when reverse gear is engaged.

1. Press the **CAR** button.
2. Press the **OPTION** button or touch the tab of the same name in the header.
3. Select **"SET CAR"**
  - > **"Vehicle functions"**
  - > **"Light & visibility"**
  - > **"Reversing options"**.
4. Select **"Lowering mirror"** to activate () or deactivate () the function.

### Setting opening of the rear blind

You can set whether the rear blind is to be opened automatically when reverse gear is engaged.

1. Press the **CAR** button.
2. Press the **OPTION** button or touch the tab of the same name in the header.
3. Select **"SET CAR"**
  - > **"Vehicle functions"**
  - > **"Light & visibility"**
  - > **"Reversing options"**.
4. Select **"Blind Opening"** to activate () or deactivate () the function.

## Setting comfort options

### Setting doors for unlocking via remote control (only available for the Cayenne)

You can choose which doors are unlocked after the remote control is pressed. The **"All doors"** and **"Driver's door"** options are available.

1. Press the **CAR** button.
2. Press the **OPTION** button or touch the tab of the same name in the header.
3. Select **"SET CAR"**
  - > **"Vehicle functions"**
  - > **"Locking"**
  - > **"Door unlock"**.
4. Select the option you want.

### Setting automatic door locking (only available for the Cayenne)

In the **"Door lock"** menu, you can choose whether the doors are to be locked again automatically after switching on the ignition or after driving off as soon as a speed of 5-10 km/h (3-6 mph) has been exceeded.



1. Press the **CAR** button.
2. Press the **OPTION** button or touch the tab of the same name in the header.

3. Select **"SET CAR"**
  - > **"Vehicle functions"**
  - > **"Locking"**
  - > **"Door lock"**.
4. Select the option you want.  
By selecting **"Off"** the function is deactivated.

### Setting the duration for relocking (only available for the Cayenne)

Automatic relocking of your vehicle locks the boot lid and doors again if they are not opened within a certain time after being unlocked.

You can set the period of time after which the doors and boot are to be locked again in the **"Relock time"** menu.

1. Press the **CAR** button.
2. Press the **OPTION** button or touch the tab of the same name in the header.
3. Select **"SET CAR"**
  - > **"Vehicle functions"**
  - > **"Locking"**
  - > **"Relock time"**.
4. Select **"...s Door unlock"** or **"...s Boot"**, depending on which setting you wish to change.
5. Set the desired time period by touching the two symbols  and  or by turning the right rotary knob .
6. The setting is applied immediately.

### Setting automatic folding in the exterior mirrors

You can set whether the exterior mirrors are to be folded in automatically when the vehicle is switched off.

1. Press the **CAR** button.
2. Press the **OPTION** button or touch the tab of the same name in the header.
3. Select “**SET CAR**”
  - > “**Vehicle functions**”
  - > “**Locking**”.
4. Select “**Mirror retract**” to activate (☒) or deactivate (☐) the function.

### Activating the entry aid

If this function is activated, the steering wheel and driver’s seat are retracted automatically to make it easier to get in and out of the vehicle.

1. Press the **CAR** button.
2. Press the **OPTION** button or touch the tab of the same name in the header.
3. Select “**SET CAR**”
  - > “**Vehicle functions**”
  - > “**Locking**”.
4. Select “**Comfort Entry**” to activate (☒) or deactivate (☐) the function.

### Choosing the options for setting the air conditioning

#### Setting the air flow strength

You can choose whether the air flow for the air conditioning is to be set to “**Soft**”, “**Normal**” or “**Strong**”.

1. Press the **CAR** button.
2. Press the **OPTION** button or touch the tab of the same name in the header.
3. Select “**SET CAR**”
  - > “**Vehicle functions**”
  - > “**Air conditioning**”
  - > “**Climate style**”.
4. Select the setting you want.

#### Setting adaptation of the central vents

If this function is activated, the output temperature at both central vents in the dashboard is adapted.

1. Press the **CAR** button.
2. Press the **OPTION** button or touch the tab of the same name in the header.
3. Select “**SET CAR**”
  - > “**Vehicle functions**”
  - > “**Air conditioning**”.
4. Select “**Centre cooler**” to activate (☒) or deactivate (☐) the function.

### Setting use of the upper ventilation zone

If this function is activated, the upper ventilation zone is also taken into account for the automatic air conditioning system.

1. Press the **CAR** button.
2. Press the **OPTION** button or touch the tab of the same name in the header.
3. Select “**SET CAR**”
  - > “**Vehicle functions**”
  - > “**Air conditioning**”.
4. Select “**Vent. panel**” to activate (☒) or deactivate (☐) the function.

### Setting automatic air circulation

If this function is activated, the fresh air supply is shut off and the air circulation function is activated if the air quality is poor.

1. Press the **CAR** button.
2. Press the **OPTION** button or touch the tab of the same name in the header.
3. Select “**SET CAR**”
  - > “**Vehicle functions**”
  - > “**Air conditioning**”.
4. Select “**Auto air circ.**” to activate (☒) or deactivate (☐) the function.

General operation .....	126	Personal destination memory .....	131	Stopovers (tour) .....	139
Navigation safety notice .....	127	Storing an address for		Entering stopovers .....	139
Setting the volume of the		personal destinations .....	131	Via destinations .....	140
navigation announcement .....	127	Entering an address for		Deleting stopovers .....	140
Repeating a navigation announcement .....	127	route guidance from the list .....	131	Storing stopovers in the	
Entering an address .....	127	route guidance from the list .....	131	personal destination memory .....	141
Entering the country .....	127	Displaying the location of a destination .....	131	Reorganising the stopovers .....	141
Entering the town/postal code .....	128	Editing the address of a destination .....	132	Destination input using	
Entering the street/number .....	128	Adding destinations .....	132	geographical coordinates .....	141
Entering the junction .....	128	Entering/editing a telephone number		Destination input using the map .....	142
Starting/stopping route guidance .....	128	for a destination in the		Storing .....	142
Starting route guidance .....	128	destination memory .....	132	Storing a destination .....	142
Stopping route guidance .....	128	Editing the destination name .....	132	Storing a position .....	142
Activating alternative routes for		Calling the destination .....	132	Off-road navigation .....	143
route guidance .....	128	Deleting a destination .....	133	Activating/deactivating	
Starting route guidance with		Bluetooth® settings .....	133	off-road navigation .....	143
route alternatives activated .....	128	Points of interest .....	135	Safety notice for off-road navigation .....	144
Displaying information for		Searching for points of interest		Landmark navigation .....	144
traffic messages on the route .....	129	by category .....	135	Recording a trip section (trace) .....	145
List of previous destinations .....	129	Searching for points of interest		Tracing a route .....	146
Entering an address for a		by name .....	136	Reloading data .....	147
new route guidance session from		Searching for points of interest		Changing the navigation database .....	147
the list .....	130	by telephone number .....	136		
Displaying the location of a destination .....	130	Searching for points of interest			
Editing the address of a destination .....	130	in the map view .....	136		
Deleting .....	130	Starting navigation to the			
Storing a destination in the		point of interest .....	136		
personal destination memory .....	130	Changing options for route guidance .....	136		
Calling the destination .....	130	Setting a detour .....	136		
		Cancelling a detour .....	137		
		Setting a fast/quick route .....	138		
		Setting dynamic route planning (TMC) .....	138		
		Avoiding a stretch of road .....	138		

The PCM navigation system utilises visual and audible driving recommendations to help you reach your destination.

The vehicle's position is determined with the aid of a GPS antenna and a receiver in the navigation module.

The vehicle position is calculated by evaluating and processing additional vehicle signals (e.g. speed) in the navigation computer. This enables the system to automatically correct signal changes due to wheel changes (altered tyre diameter), temperature or air pressure variations. The PCM features a hard drive where the digital map data is stored.

If an area on this hard drive is damaged or corrupt, the PCM can no longer access the data on it. A message to this effect will be displayed.

**i** During an active telephone call, the driving recommendations are suppressed.

#### **WARNING**

**Accident hazard. The navigation system is only intended as an aid to the driver and makes recommendations on the routes to take. This does not release you from full responsibility for observing road safety, traffic conditions, legal road traffic regulations and any other relevant regulations while driving your vehicle.**

**As the driver, you must assess the traffic situation. You have sole responsibility for road safety while driving your car.**

▷ Continue to pay attention to the traffic situation.

### **General operation**

To ensure you make the most effective use of your PCM navigation system, please observe the following points:

- GPS reception can be impaired under trees or between high buildings. No GPS reception is possible in multi-storey car parks, tunnels and the like.
- The GPS antenna must not be covered by metallic or damp objects.

- After the vehicle's on-board voltage has been interrupted (e.g. for changing the vehicle battery), it can take up to 15 minutes or more depending on the reception conditions for the GPS to re-initialise.
- After transporting the vehicle, for example by ferry, it can take several minutes depending on the reception conditions after switching on until the current GPS position is established.
- Without GPS reception, the system calculates the current position using the vehicle signals and therefore remains operational in situations where the reception is temporarily poor.
- High wheel slip (spin on snow) can result in an incorrect position being given for a short time.
- After initial start-up of the navigation system, the fine calibration requires approx. 50 km (30 miles).
- After a tyre change (e.g. summer/winter tyres), fine calibration will only be reached after up to 50 km (30 miles).
- During fine calibration, full location accuracy is not yet reached.

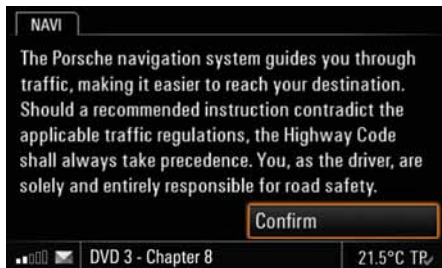

### Navigation safety notice

You are shown a message that the navigation system is only intended as an **aid** to the driver as soon as you:

- have switched on the PCM and activated route guidance

or

- have switched on the PCM and pressed the **NAVI** button or **MAP** button for the first time.

- ▷ Close the safety notice by selecting “**Confirm**”.



### Setting the volume of the navigation announcement

1. Press the **NAVI** button.
2. Press the **OPTION** button or touch the tab of the same name in the header.
3. Select “**SET NAVI**”  
> “**Guidance volume**”.
4. Make the setting you want by selecting the two symbols  and .

### Repeating a navigation announcement

- ▷ After you have listened to the navigation announcement, press the **MAP** button twice in succession.

The navigation announcement is repeated.

-  While the navigation announcement is being repeated, you can adjust the volume of the navigation announcement by turning the left rotary knob .

The changed volume is set and stored.

### Entering an address

After you select “**Enter address**”, the address of the last destination is displayed in the information area.

If route guidance is active, the address of the current destination is displayed.

-  Observe the following points for destination input:
  - Destination input is only possible using the data available on the hard drive of the device.

There may be restrictions regarding street names, street numbers, city centres and points of interest. This applies particularly if the destination is located in a partly digitised area (map data for this area is inaccurate or incomplete).

- We are constantly working to collect further data and update available data. Information regarding new or updated software is available from your Porsche partner.

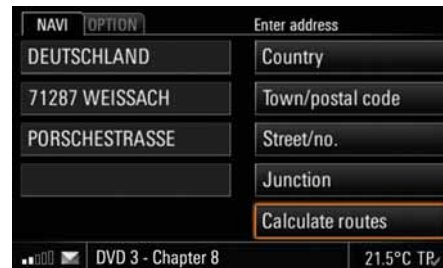

### Entering the country

After you first select address entry, only the “**Country**” menu item can be selected. You must enter a country before you can enter the remaining address data.

#### Selecting a country in the list

1. Press the **NAVI** button.
2. Select “**Enter address**”  
> “**Country**”.  
A list of the countries for which navigation data is stored on the hard drive is opened.
3. Select the country you want in the list.

#### Selecting a country in the map

1. Press the **NAVI** button.
2. Select “**Enter address**”  
> “**Country**”.  
A list of the countries for which navigation data is stored on the hard drive is opened.
  - > Select “**Country via map**”.  
A map of Europe is opened.

3. Touch the upper or lower map section depending on the country you want to choose. An enlarged map section containing the relevant country abbreviations is displayed.
4. Select the country you want in the map.

### Entering the town/postal code

You can enter the town either by means of its name or its postal code.

1. Press the **NAVI** button.
2. Select **“Enter address”**  
> **“Town/postal code”**.  
The input menu is opened.
3. Enter the town name or the postal code. After you enter the first letters of the town and confirm by selecting **“OK”**, a list containing possible matches is opened.
4. Select the town you want in the list.  
- or -
4. Highlight a town in the list and select **“Details”** in the header.  
A map section containing the previously highlighted town is opened. If there are several towns with this name, you can switch between the different map views by touching the symbols ◀ and ▶ on the display.
5. Select **“OK”** to use the town displayed in the map section for route guidance.

### Entering the street/number

1. Press the **NAVI** button.
2. Select **“Enter address”**  
> **“Street/no.”**.  
The input menu is opened.
3. Enter the street name. After you enter the first letters of the street name, a list containing possible matches is opened.
4. Select the street you want in the list.  
**i** You can also enter the street number later (when route guidance is already active). If you do so, however, you must then restart route guidance.

### Entering the junction

1. Press the **NAVI** button.
2. Select **“Enter address”**  
> **“Junction”**.  
The input menu is opened.
3. Enter the name of the cross street. After you enter the first letters of the street name, a list containing possible matches is opened.
4. Select the street you want in the list.

## Starting/stopping route guidance

### Starting route guidance

To be able to start route guidance, you must have entered at least a country and a town.

- ▷ After entering the address data, select **“Start route guidance”** to start route guidance.

### Stopping route guidance

- ▷ Select **“Stop route guidance”** in the main menu during an active route guidance session to stop route guidance.

### Activating alternative routes for route guidance

1. Press the **NAVI** button.
2. Press the **OPTION** button or touch the tab of the same name in the header.
3. Select **“SET NAVI”**.
4. Select **“Route alternatives”** to activate (☑) or deactivate (☐) the function.

### Starting route guidance with route alternatives activated

If you have activated the route alternatives in the settings menu, the **“Start route guidance”** menu item is replaced with the **“Calculate routes”** menu item.



1. Enter an address.
2. Select **“Calculate routes”**.  
The route alternatives are calculated. Any stop-overs and via destinations that you have entered are also taken into account in the calculation.  
The possible alternative routes are displayed.
3. Choose the route you want for the calculation by selecting it.
4. Select **“Start route guidance”** to start the route guidance.

### Displaying information for traffic messages on the route

If the **“Traffic warning”** function is activated, information is displayed for each traffic message

- that is on the current route and
- that is at least 10 minutes before the last possible exit before the traffic jam.

 **“Traffic warning”** can only be activated if dynamic route planning is deactivated.

1. Press the **NAVI** button.
2. Press the **OPTION** button or touch the tab of the same name in the header.
3. Select **“SET NAVI”**.
4. Select **“Traffic warning”** to activate () or deactivate () the function.

A prompt must be confirmed as soon as it is displayed. The following options are available to you:

- ▷ Select **“Detour”**.  
A new route is calculated taking the relevant traffic message into account.
- ▷ Select **“Ignore”**.  
The original route guidance session is resumed. The traffic message is not taken into account.
- ▷ Select **“Details”**.  
The detailed view of the traffic message is displayed.
  - > Select **“Detour”** to close the detailed view and calculate a new route.
  - or -
  - > Press the Back button  to close the detailed view again and ignore the traffic message.

 You can also close the message or detailed view at any time by pressing any button.

### List of previous destinations

This list automatically stores the previous 100 destinations for which you started route guidance. Points of interest are indicated by symbols.



Point of interest  
To find out more, please refer to the section „POINTS OF INTEREST“ on page 135.



Geographical coordinate  
To find out more, please refer to the section „DESTINATION INPUT USING GEOGRAPHICAL COORDINATES“ on page 141.



Point positioning  
To find out more, please refer to the section „INSERTING A DESTINATION FROM THE MAP (POINT POSITIONING)“ on page 140.

You can call up, edit and store the destinations for a new route guidance session.



### Entering an address for a new route guidance session from the list

1. Press the **NAVI** button.
2. Select **“Previous destinations”**.  
The list of previous destinations is opened.
3. Select the destination you want.
4. Select **“Start route guidance”** to start the route guidance.

### Displaying the location of a destination

1. Press the **NAVI** button.
2. Select **“Previous destinations”**.  
The list of previous destinations is opened.
3. Select the destination you want.
4. Select **“Details”**.  
The location of the chosen destination is shown in the map view. To find out more, please refer to the section „MAP“ on page 149.
5. Select **“Start route guidance”** to start the route guidance if needed.

### Editing the address of a destination

1. Press the **NAVI** button.
2. Select **“Previous destinations”**.  
The list of previous destinations is opened.
3. Select the destination you want.
4. Select **“Edit”**  
> **“Address”**.  
The address entry menu is opened.
5. Make the changes you want.

### Deleting

1. Press the **NAVI** button.
2. Select **“Previous destinations”**.  
The list of previous destinations is opened.
3. Select the destination you want.
4. Select **“Edit”**  
> **“Delete”**.

### Deleting a destination from the list

5. Confirm the prompt that appears by selecting **“Yes”**.  
The chosen destination is deleted from the list.

### Deleting the entire list

5. Select **“Delete list”**  
> **“Delete all”**.  
The entire list is deleted.

### Storing a destination in the personal destination memory

Storing of destinations in the list of previous destinations takes place automatically. If all the memory locations are full, the PCM automatically deletes the oldest entry from the list.

If you want to keep a destination permanently available, you can store it in your personal destination memory under a name of your choice.

1. Press the **NAVI** button.
2. Select **“Previous destinations”**.  
The list of previous destinations is opened.
3. Select the destination you want.
4. Select **“Store”**.  
The input menu is opened.
5. Enter the destination name you want and confirm by selecting **“OK”**.  
The destination is stored in the personal destination memory.

### Calling the destination

You can call individual points of interest for which there is a telephone number in the database from the list of previous destinations. This menu item is not available if there is no telephone number stored in the database for a destination or if the telephone function is not available. **“Store position”** is displayed instead.

1. Press the **NAVI** button.
2. Select **“Previous destinations”**.  
The list of previous destinations is opened.
3. Select the destination you want.
4. Select **“Call”**.  
The number stored in the database is dialled.

## Personal destination memory

In your personal destination memory you can store 100 destination entries as well as 15 off-road navigation routes (traces) under freely defined names. The personal destination memory also contains the two personal destinations “GO HOME” and “GO TO OFFICE” that can be assigned the corresponding addresses and are always displayed at the top of the list.

Points of interest are indicated by symbols.



POI

To find out more, please refer to the section „POINTS OF INTEREST“ on page 135.



Geo. co-ordinates

To find out more, please refer to the section „DESTINATION INPUT USING GEOGRAPHICAL COORDINATES“ on page 141.



Point positioning

To find out more, please refer to the section „INSERTING A DESTINATION FROM THE MAP (POINT POSITIONING)“ on page 140.



Stopovers (tour)

To find out more, please refer to the section „STOPOVERS (TOUR)“ on page 139.



Trace

To find out more, please refer to the section „OFF-ROAD NAVIGATION“ on page 143.



Landmark list

To find out more, please refer to the section „OFF-ROAD NAVIGATION“ on page 143.

## Storing an address for personal destinations

Here is an example of how to enter the address for the personal destination “GO HOME”:

1. Press the **NAVI** button.
2. Select “**Stored destinations**”.
3. The personal destination memory is opened.
3. Select “**GO HOME**”.
4. Confirm the prompt that appears with “**Yes**”.

### Storing an address by entering it

5. Select “**Enter address**”.
6. If applicable, select “**Country**” and select the country you want in the list.
7. Select the “**Town/postal code**” and “**Street/no.**” menu items one after the other and enter the appropriate details in the input menu.
8. Select “**Store**” to store the entered address for the entry.

### Inserting an address from a list

5. Select “**Previous destinations**” or “**Stored destinations**”.
  6. Select the address you want in the list.
- The address is accepted.



It is not possible to store a tour, a trace or a landmark list as a personal destination.

## Adding an address from a POI search

5. Select “**POI**”.

For the rest of the procedure, please refer to the section „POINTS OF INTEREST“ on page 135.

## Entering an address for route guidance from the list

1. Press the **NAVI** button.
2. Select “**Stored destinations**”.
3. The personal destination memory is opened.
3. Select the destination you want.
4. Select “**Start route guidance**” to start the route guidance.

## Displaying the location of a destination

1. Press the **NAVI** button.
  2. Select “**Stored destinations**”.
  3. The personal destination memory is opened.
  3. Select the destination you want.
  4. Select “**Details**”.
- The location of the chosen destination is shown in the map view. To find out more, please refer to the section „MAP“ on page 149.
5. Select “**Start route guidance**” to start the route guidance if needed.

## Editing the address of a destination

1. Press the **NAVI** button.
2. Select **“Stored destinations”**.  
The personal destination memory is opened.
3. Select the destination you want.
4. Select **“Edit”**  
> **“Address”**.  
The address entry menu is opened.
5. Make the changes you want.
6. Select **“Accept”**.
7. The old data is overwritten.

## Adding destinations

**i** Traces cannot be added with this menu item.

1. Press the **NAVI** button.
2. Select **“Stored destinations”**.  
The personal destination memory is opened.
3. Select **“Add destinations”**.

## Adding addresses by address entry

4. Select **“Enter address”**.
5. If applicable, select **“Country”** and select the country you want in the list.
6. Select the **“Town/postal code”** and **“Street/no.”** menu items one after the other and enter the appropriate details in the input menu.
7. Select **“Store”** to store the entered address for the entry.

## Adding destinations by loading from a USB

4. Select **“Load from USB”**.

The data is transferred.

**i** You can only access the **“Load from USB”** transmission mode if there is a USB memory stick attached to the USB interface. To find out more about the permissible USB memory media, please refer to the section „NOTES ON THE MEDIA SUPPORTED“ on page 40.

## Entering/editing a telephone number for a destination in the destination memory

In the personal destination memory you can create a telephone number for each destination for standard navigation.

You cannot enter or edit a telephone number if the destination you want is a trace or a point of interest (destinations for off-road navigation).

1. Press the **NAVI** button.
2. Select **“Stored destinations”**.  
The personal destination memory is opened.
3. Select the destination you want.
4. Select **“Edit”**  
> **“Telephone number”**.  
The input menu for telephone numbers is opened.
5. Enter the number you want and confirm by selecting **“OK”**.

## Editing the destination name

**i** The two personal destinations **“GO HOME”** and **“GO TO OFFICE”** cannot be renamed.

1. Press the **NAVI** button.
2. Select **“Stored destinations”**.  
The personal destination memory is opened.
3. Select the destination you want.
4. Select **“Edit”**  
> **“Destination name”**.  
The input menu is opened.
5. Make the change you want and confirm by selecting **“OK”**.

## Calling the destination

You can store a telephone number for destinations held in the personal destination memory. This menu item is not available if the telephone function is not available or if you have not stored a telephone number for the destination.

1. Press the **NAVI** button.
2. Select **“Stored destinations”**.  
The personal destination memory is opened.
3. Select the destination you want.
4. Select **“Call”**.  
The number stored in the database is dialled.

**i** Telephone numbers are also stored for the points of interest held on the hard drive. If, for example, you select a point of interest in the map view, you can establish a telephone connection by selecting **“Call”** in the detailed view of the map view.

To find out more, please refer also to the section „SEARCHING FOR POINTS OF INTEREST IN THE MAP VIEW“ on page 136.

## Deleting a destination

1. Press the **NAVI** button.
2. Select **"Stored destinations"**.  
The personal destination memory is opened.
3. Select the destination you want.
4. Select **"Edit"**  
> **"Delete"**.

## Deleting a destination from the list

5. Confirm the prompt that appears by selecting **"Yes"**.  
The chosen destination is deleted from the list.

## Deleting the entire list

5. Select **"Delete list"**  
> **"Delete all"**.  
The entire personal destination memory is deleted. Deletion also affects the two personal destinations **"GO HOME"** and **"GO TO OFFICE"**.

## Sending a destination

You can send individual destinations from the personal destination memory as a text message in the form of a vCard or via the *Bluetooth*<sup>®</sup> interface.

1. Press the **NAVI** button.
2. Select **"Stored destinations"**.  
The personal destination memory is opened.
3. Select the destination you want.
4. Select **"Edit"**  
> **"Send"**.

## Sending a destination via USB

**i** You can only access the **"To USB"** transmission mode if there is a USB memory stick attached to the USB interface. To find out more about the permissible USB memory media, please refer to the section „NOTES ON THE MEDIA SUPPORTED“ on page 40.

5. Select **"To USB"**.  
The data is transferred.

**i** This data is transmitted in the **"\*.navi"** data format.

## Sending a destination as a text message

5. If you choose **"As SMS"**, you must enter the telephone number of the recipient in the input menu that appears.  
You can also select the number from the phonebook by selecting the corresponding menu item. To find out more, please refer to the section „CREATING AND SENDING A NEW TEXT MESSAGE“ on page 76.

## Sending a destination via the Bluetooth interface

**i** Please note that the radio connection between both devices must be activated for data transfer using *Bluetooth*<sup>®</sup>. To find out how to activate this radio connection, please refer to the section „SWITCHING BLUETOOTH<sup>®</sup> ON“ on page 133.

5. Select **"To Bluetooth"**.

6. The list of known devices that are suitable for a transfer is displayed. If the device you want is not there, you can search for further devices. To do this, press **"New device"** (see also the section „POINTS OF INTEREST“ on page 135).

As soon as the search is complete, a list containing the devices found is displayed.

7. Select the device you want.

**i** You may first need to authorise a new device. To find out more, please refer to the section „POINTS OF INTEREST“ on page 135.

## *Bluetooth*<sup>®</sup> settings

### Calling up *Bluetooth*<sup>®</sup> settings

1. Press the **NAVI** button.
2. Select **"Stored destinations"**.  
The personal destination memory is opened.
3. Select a destination.
4. Select **"Edit"**  
> **"Send"**  
> **"Bluetooth settings"**.

### Switching *Bluetooth*<sup>®</sup> on

- ▷ Select **"Switch on Bluetooth"** in the *Bluetooth*<sup>®</sup> settings.

### Switching *Bluetooth*<sup>®</sup> off

- ▷ Select **"Switch off Bluetooth"** in the *Bluetooth*<sup>®</sup> settings.

### Adding a new **Bluetooth®** device

For the PCM to find your **Bluetooth®** device, please ensure that the **Bluetooth®** function on the device has been activated and set to “visible”.

1. Select “**New data device**” in the **Bluetooth®** settings.

A search is started and a list of the devices found is displayed.

2. Choose the device you want by selecting it in the list.

A **Bluetooth®** code is displayed that you must enter in the corresponding **Bluetooth®** device. Once you have entered the code, successful authorisation of the device is shown on the display.

### Establishing a connection from an external **Bluetooth®** device

To find out more, please refer to the section „ESTABLISHING A CONNECTION FROM AN EXTERNAL BLUETOOTH® DEVICE“ on page 62.

### Setting visibility

To find out more, please refer to the section „SETTING VISIBILITY“ on page 63.

### Authorised **Bluetooth®** devices

This function allows you to display a list of the **Bluetooth®** devices currently authorised to connect with your PCM. The list contains all authorised data devices .

### Displaying authorised **Bluetooth®** devices

- ▷ Select “**List of data devices**” in the **Bluetooth®** settings.

### Connecting an authorised **Bluetooth®** device with the PCM

 Data devices cannot be connected from the list of devices; they can only be connected by calling the appropriate application, for example when transferring a stored destination.

### Renaming an authorised **Bluetooth®** device

1. Select “**List of data devices**” in the **Bluetooth®** settings.
2. Select the device you want in the list.
3. Select “**Rename**”.  
The input menu is opened.
4. Enter the name you want and confirm by selecting “**OK**”.

The name of the device is now changed in the PCM.

### Deleting an authorised **Bluetooth®** device from the list

1. Select “**List of data devices**” in the **Bluetooth®** settings.
2. Select the device you want in the list.
3. Select “**Delete**”.
4. Confirm the prompt that appears by selecting “**Yes**”.

### Deleting the list of authorised **Bluetooth®** devices

1. Select “**List of data devices**” in the **Bluetooth®** settings.
2. Select any device in the list.
3. Select “**Delete**”.
4. Select “**Delete list**”.
5. Confirm the prompt that appears by selecting “**Delete all**”.

### Displaying details for the authorised **Bluetooth®** device

1. Select “**List of data devices**” in the **Bluetooth®** settings.
2. Select any device in the list.
3. Select “**Device details**”.  
The following information is displayed:
  - the device name,
  - the **Bluetooth®** address as well as
  - the supported services.

## Points of interest

Points of interest are petrol stations, car parks, restaurants, hotels or hospitals, for example. They are divided into different categories to make them easier for you to find.

This function is also available in reduced form in the **OPTION** menu of the map view:

- when route guidance is active under the **“Search on route”** menu item,
- when route guidance is not active under the **“Search surroundings”** menu item.

### Searching for points of interest by category

1. Press the **NAVI** button.
2. Select **“POI”**  
> **“Category”**.  
A list of the available categories is opened.
3. Select the category you want from the list.  
A list containing the subcategories is opened.
4. Select the subcategory you want.

5. You can also restrict the search area if you wish after selecting **“Search radius”**:
  - **“Vehicle surroundings”**  
The search is performed in the vicinity of the current location.
  - **“Near destination”**  
The search is performed in the vicinity of the currently active destination.
  - **“Along route”**  
The search is performed along the calculated route.
  - **“Free location input”**  
The search is performed in a user-defined location. You can enter this location in the input menu.
6. Select the search area you want.
7. Start the search by selecting **“Show results”**.  
A list containing the search result is displayed.

**i** The **“Near destination”** and **“Along route”** menu items are only available during an active route guidance session after the route has been calculated.

**i** If you chose **“Free location input”** as the search area, you can expand the radius for a new search by selecting the **“Area search”** menu item in the result list.

**i** The result lists for the **“Vehicle surroundings”** and **“Near destination”** search areas show the distance as the crow flies, while the result list for the **“Along route”** search area shows the actual distance.

**i** You can set alphabetical sorting for the **“Near destination”** search area by selecting the first list entry, **“Alphabetical list”**.

8. Select the point of interest you want.

**i** If you fill a data field with the **“Distance to next petrol station”** menu item in the personal display of the CAR menu, you can start a route calculation to this petrol station by touching the symbol in the data field.

To find out more, please refer to the section „SETTING THE CONTENTS OF THE PERSONAL DISPLAY“ on page 100.

## Searching for points of interest by name

1. Press the **NAVI** button.
2. Select “**POI**”.
3. Specify “**Category**” and “**Search radius**” if applicable.
4. Select “**Name**”.  
The input menu is opened.
5. Enter the first letters of the name of the point of interest. After you enter the first letters of the name, a list containing possible matches is opened.

- i** If there are fewer than five points of interest stored for the selected category and search area, a list of the points of interest is opened instead of the input menu.
6. Select the point of interest you want in the list.

## Searching for points of interest by telephone number

1. Press the **NAVI** button.
2. Select “**POI**”.
3. Select “**Telephone number**”.  
The input menu is opened.
4. Enter the telephone number with country code (without “+” or “00”) and confirm by selecting “**OK**”.  
If there is more than one address stored for the telephone number you have just entered, a list of the addresses is opened.
5. Select the address you want if necessary.



## Searching for points of interest in the map view

- >** Briefly touch the symbol for the point of interest in the map view.  
An orange-coloured ring appears around the point of interest and the name of the point of interest and the “**Details**” menu are displayed in the header.  
Open the detailed view by pressing the right rotary knob  or touching the “**Details**” menu in the header.
- i** You can also view the details for a traffic message or destination flag shown on the display by touching them.

## Starting navigation to the point of interest

1. Press the **NAVI** button.
2. Select “**POI**”.  
- or -  
Touch the map view.
3. Select the point of interest you want.
4. Select “**Start route guidance**”.  
The route is calculated and route guidance started.

## Changing options for route guidance

- i** The options for route guidance are also available to you in the map view.

## Setting a detour

To be able to set a detour, you must have activated the route guidance component of your navigation system.  
If you set a number of detours, they always refer to the current route. Older route calculations are discarded.

## Setting a detour from the current position

1. Press the **NAVI** button.
2. Press the **OPTION** button or touch the tab of the same name in the header.
3. Select “**Route options**”  
**>** “**Detour**”  
**>** “**Distance ahead**”.  
The map view is displayed. You can see your current position as well as the route ahead.



- Switch from one part of the route section to the next by selecting the two symbols ◀ and ▶ or by turning (⦿) the right rotary knob.

- Select **"Detour"** once you have set the part of the route up to where you want to activate a detour.

The new route is calculated. The ⚡ symbol is displayed before the **"Distance ahead"** menu item.



### Setting an alternative route

- Press the **NAVI** button.
- Press the **OPTION** button or touch the tab of the same name in the header.
- Select **"Route options"**
  - > **"Detour"**
    - > **"Show alt. routes"**.  
The map view is displayed. You can see your current route.  
The current route guidance session is aborted.
- You can show alternative route suggestions in the map view by selecting **"Route 1"**, **"Route 2"** or **"Scenic route"**.
- Select **"Start route guidance"** to accept one of these routes after highlighting it.

**i** If you exit the menu by pressing the ⬅ button, the previously active route guidance is resumed and detours already set are discarded.

### Making a detour around route sections

The list of route sections shows the individual sections of the calculated route. The section you are currently driving on when you call up the list appears at the top of the list.

- Press the **NAVI** button.
- Press the **OPTION** button or touch the tab of the same name in the header.
- Select **"Route options"**
  - > **"Detour"**
    - > **"Route sections"**.  
The list of route sections is displayed.
- Select the route section you want.  
A list containing the parts of this route section is displayed.
- Select the parts to activate () or deactivate () them.
- Press the Back button ⬅ or the **NAVI** button to activate the detour.
- The detour is then set. This is indicated by the ⚡ symbol in front of the **"Route sections"** menu item.

### Cancelling a detour

Selecting **"Detour off"** cancels all previously set detours.

The ⚡ symbol is no longer displayed and a new route is calculated.

- Press the **NAVI** button.
- Press the **OPTION** button or touch the tab of the same name in the header.

### 3. Select “Route options”

> “Detour”

> “Detour off”.

All blocks are cancelled.

### Setting a fast/quick route

These two route options allow you to influence how the route is calculated.

You can set or change the route options before the route is calculated or during route guidance.

1. Press the **NAVI** button.

2. Press the **OPTION** button or touch the tab of the same name in the header.

3. Select “Route options”.

4. Activate or deactivate the route option you want by selecting it.

– **Short route**

Calculates the shortest route to the destination.

– **Quick route**

Calculates the fastest route to the destination.

### Setting dynamic route planning (TMC)

If you have activated dynamic route planning, the traffic messages broadcast by the radio stations are taken into consideration when calculating the route.

To find out more about traffic messages, please refer to the section „DISPLAYING TRAFFIC MESSAGES (TMC)“ on page 96.

1. Press the **NAVI** button.

2. Press the **OPTION** button or touch the tab of the same name in the header.

3. Select “Route options”.

4. Select “Dynamic reroute ) or deactivate () the function.

### Avoiding a stretch of road

Selecting “Avoid” allows you to set restrictions for route planning.

If a restriction is activated (), the PCM calculates a route without this type of road. The  symbol is displayed before the “Avoid” menu item.

If route planning is not possible with the restriction you have set, you are informed of this in an appropriate message.

1. Press the **NAVI** button.

2. Press the **OPTION** button or touch the tab of the same name in the header.

3. Select “Route options”

> “Avoid”.

The following menu items are then available for you to select:

– “Toll 

– “Motorway 

– “Ferry / Car train 

– “Tunnel 

– “Mountain passes 

4. Select the respective menu items to activate () or deactivate () the function. The route is recalculated.

## Stopovers (tour)

You can enter up to four stopovers during an active navigation session and arrange them in any order. The route is recalculated and the destinations are then called at in a so-called tour.

As soon as a stopover is approached as an active destination, it is also displayed in the list of previous destinations.

The complete tour is displayed in the form of a list of destinations. The currently active destination is at the top of the list.

The main destination of the tour is indicated by a black and white destination flag  and is the last entry in the list.

**i** If the active navigation session is an off-road session, the “**Stopovers**” and “**As stopover**” menu items are replaced with the “**List of landmarks**” and “**As landmark**” menu items.

To find out more about off-road navigation, please refer to the section „OFF-ROAD NAVIGATION“ on page 143.

## Entering stopovers

### By entering an address

1. Press the **NAVI** button.
2. Press the **OPTION** button or touch the tab of the same name in the header.
3. Select “**Stopovers**”
  - > “**Add**”
    - > “**Enter address**”.The address input menu is opened.
4. Enter the address you want.
5. Select “**Accept**”.

If you have already entered at least one stopover, a destination list is opened where you can define the position of the stopover you are in the process of entering.

6. Position the stopover by selecting the “**empty**” list entry at the position you want in the list.

### From the list of previous destinations

1. Press the **NAVI** button.
2. Press the **OPTION** button or touch the tab of the same name in the header.
3. Select “**Stopovers**”
  - > “**Add**”
    - > “**Previous destinations**”.The list of previous destinations is opened.
4. Select the destination you want.  
The destination is accepted as a stopover.

## From the destination memory

1. Press the **NAVI** button.
2. Press the **OPTION** button or touch the tab of the same name in the header.
3. Select “**Stopovers**”
  - > “**Add**”
    - > “**Stored destinations**”.The personal destination memory is opened.
4. Select the destination you want.  
The destination is accepted as a stopover.

### Entering a point of interest as a stopover

1. Press the **NAVI** button.
2. Press the **OPTION** button or touch the tab of the same name in the header.
3. Select “**Stopovers**”
  - > “**Add**”
    - > “**POI**”.The POI search is opened.
4. Select the point of interest you want.  
The destination is accepted as a stopover.  
To find out more about the POI search, please refer to the section „POINTS OF INTEREST“ on page 135.

### Entering a stopover using geographical coordinates

1. Press the **NAVI** button.
2. Press the **OPTION** button or touch the tab of the same name in the header.

3. Select **“Stopovers”**
  - > **“Add”**
    - > **“Adv. destination input”**
      - > **“Geo. co-ordinates”**.  
An input menu for geographical coordinates is opened.
4. Enter the geographical coordinates you want and confirm by selecting **“OK”**.

### Entering a stopover using the map

1. Press the **NAVI** button.
2. Press the **OPTION** button or touch the tab of the same name in the header.
3. Select **“Stopovers”**
  - > **“Add”**
    - > **“Adv. destination input”**
      - > **“Destination via map”**.  
The map view is displayed.
4. Set the destination you want by touching the map and confirm by selecting **“OK”**.

### Inserting a destination from the map (point positioning)

1. Touch the map view when route guidance is underway.  
A crosshair is displayed.
2. Touch the symbol for a point of interest or any other point in the map view.  
The name of the point of interest or the address of the chosen point is displayed in the header.

3. Open the detailed view by pressing the right rotary knob  or by touching the header.
4. Select **“As stopover”**.  
The chosen destination is stored in the destination list as point positioning and indicated with the  symbol.

### Via destinations

If you have selected a motorway junction as a stopover, this stopover is interpreted as a via destination.

As soon as a stopover is approached as an active destination, the via destination is also displayed in the list of previous destinations.

No estimated time of arrival is given for via destinations.

### Deleting stopovers

1. Press the **NAVI** button.
2. Press the **OPTION** button or touch the tab of the same name in the header.
3. Select **“Stopovers”**
  - > **“Delete”**.  
The destination list is opened.

### Deleting a destination from the list

4. Select the destination to be deleted in the list.
5. Confirm the prompt that appears by selecting **“Yes”**.  
The destination is deleted from the list.

### Deleting the entire list

4. Select a stopover in the list.
5. Select **“Delete list”**.
6. Confirm the prompt that appears by selecting **“Yes”**.  
The entire list apart from the main destination is deleted and route guidance is resumed to the main destination.

## Storing stopovers in the personal destination memory

You can store all stopovers entered as well as the main destination individually in the personal destination memory.

1. Press the **NAVI** button.
2. Press the **OPTION** button or touch the tab of the same name in the header.
3. Select **"Stopovers"**  
> **"Store"**.  
The destination list is opened.
4. Select the destination you want to store in the list.  
The input menu is opened.
5. Enter the name you want for the destination and confirm by selecting **"OK"**.  
The destination is stored in the personal destination memory under the entered name.



## Reorganising the stopovers

1. Press the **NAVI** button.
  2. Press the **OPTION** button or touch the tab of the same name in the header.
  3. Select **"Stopovers"**  
> **"Sort new"**.
  4. Select the entries in the order you want to navigate to them.
- i** You can end the reorganisation without completing it by selecting the Back button . The stopovers not yet reorganised are then appended in their current position to those already sorted.  
Once you have reorganised all the stopovers, the list is automatically closed and route guidance to the new active destination started.

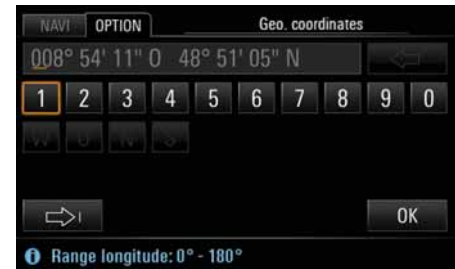

## Destination input using geographical coordinates

If you know the geographical coordinates for a destination, you can use them for destination input.

1. Press the **NAVI** button.
2. Press the **OPTION** button or touch the tab of the same name in the header.
3. Select **"Adv. destination input"**  
> **"Geo. co-ordinates"**.  
An input menu is opened.
4. Enter the geographical coordinates you want and confirm by selecting **"OK"**.
5. Select **"Start route guidance"**.  
The route is calculated and route guidance started.



## Destination input using the map

You can use the map view for destination input as an alternative to entering an address.

1. Press the **NAVI** button.
2. Press the **OPTION** button or touch the tab of the same name in the header.
3. Select **“Adv. destination input”**  
> **“Destination via map”**.  
The map view is displayed.
4. Set the destination you want by touching the map.
5. Open the detailed view by pressing the right rotary knob  or touching the **“Details”** menu in the header.
6. Select **“Start route guidance”**.
7. The route is calculated and route guidance started.

## Storing

This menu item allows you to store both a destination and your current position.

-  You can also access this function in the **OPTION** menu in the map view.

### Storing a destination

If route guidance is currently active, you can store either the destination or the entire route depending on the type of route guidance in your personal destination memory. The menu item provided here is tailored to the respective situation.

The following options are available:

- **“Store destination”**  
is displayed during route guidance to an address, a geographical coordinate or a point of interest.
- **“Store tour”**  
is displayed during route guidance to a stopover or to the main destination in a tour.
- **“Store landmarks”**  
is displayed when off-road navigation is active when tracing a landmark navigation session.

1. Press the **NAVI** button.
2. Press the **OPTION** button or touch the tab of the same name in the header.
3. Select **“Store”**.
4. Select the menu item shown (e.g. **“Store destination”**).  
The input menu is opened.
5. Enter the name you want by selecting the individual letters in the input menu and confirm your entry by pressing **“OK”**.

### Storing a position

You can store your current position in your personal destination memory as a geographical coordinate by selecting **“Store position”**.

1. Press the **NAVI** button.
2. Press the **OPTION** button or touch the tab of the same name in the header.
3. Select **“Store”**.
4. Select **“Store position”**.  
The input menu is opened.
5. Enter the name you want by selecting the individual letters in the input menu and confirm your entry by pressing **“OK”**.

## Off-road navigation

Off-road navigation allows you to navigate in non-digitised areas (no digital map data available for this area on the hard drive).

**i** Observe the applicable regulations in the country in which you are driving. Driving a vehicle off official roads is **not** permissible in all countries.

Off-road navigation is generally performed only with the aid of direction arrows and simple navigation announcements. Even when you are driving on a road available in the digital map data on the hard drive, route guidance is via direction arrows only.

Off-road navigation works best when the vehicle is located a significant distance (> 100 m (approx. 330 feet)) from the digitised road network.

### Display during off-road navigation

The following information is displayed during an active off-road navigation session:

- A compass display with a vehicle symbol in the centre of the compass rose.
- The direction to the next landmark (stopover) symbolised by an orange-coloured direction arrow.
- The directional deviation from the ideal route is symbolised by an orange-coloured arc segment.
- The distance as the crow flies to the next landmark (stopover).

### Arrival time during off-road navigation

During off-road navigation, the arrival time displayed in the **CAR** menu and elsewhere is calculated based on an assumed average speed of 36 km/h (approx. 22 mph).

### Determination of the vehicle position during off-road navigation

The vehicle position is determined with the aid of a GPS antenna and a receiver in the navigation module. GPS stands for **G**lobal **P**ositioning **S**ystem and is a satellite-assisted position tracking system.

Further vehicle signals (e.g. speed) are evaluated and processed in the navigation computer to calculate the vehicle position.

This enables the system to automatically correct signal changes due to wheel changes (altered tyre diameter), temperature or air pressure variations.

### Activating/deactivating off-road navigation

1. Press the **NAVI** button.
2. Press the **OPTION** button or touch the tab of the same name in the header.
3. Select **"SET NAVI"**  
> **"Off-road"**.
4. Select **"Off-road"** to activate () or deactivate () the function.

**i** Off-road navigation is automatically activated when you select an off-road destination (a landmark list or a trace) from the destination memory.

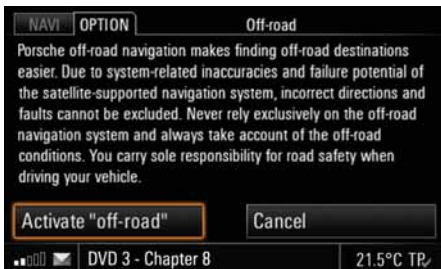

### Safety notice for off-road navigation

When you activate off-road navigation you are shown a notice that off-road navigation serves only to **assist** the driver.

- ▷ Select “**Activate „off-road”**” to close this safety notice.

### Landmark navigation

Within the framework of landmark navigation you can

- enter a destination by entering an address (> page 127),
- enter a destination by specifying the geographical coordinates (> page 141),
- enter a destination in the map view (> page 140),
- insert a destination from the list of previous destinations (> page 129),
- insert a destination from the personal destination memory (> page 131),
- enter a point of interest (> page 135) and
- enter a maximum of four stopovers, in this case termed “**Landmarks**” (> page 139).

Destinations in the digitised area can also be selected from lists and navigated to when off-road navigation is active.

These destinations are then reinterpreted as off-road destinations and navigated to using landmark navigation.

- i** During off-road navigation, only individual destinations (landmarks) are stored in the list of previous destinations. Landmark lists can be stored in the personal destination memory.

### Route guidance in landmark navigation

Route guidance is by means of a compass display with the vehicle symbol in the centre of the compass rose.

The orange-coloured direction arrow always points in the direction of the landmark currently being navigated to.

The various landmarks are shown as coloured flags.

The angular deviation between the current direction of travel and the direction to the next landmark is shown as an orange-coloured arc segment and indicated in degrees.





### Map view in landmark navigation

The individual landmarks are shown as flags in the map view:

- Orange-coloured flag: next landmark
- Blue flags: landmarks that have not yet been driven to
- Checked flag: the current destination landmark.

The routes between the landmarks that have not yet been driven are shown with a blue line.

If the route has not yet been covered in full, the portion of the line already covered is shown in orange.

Additionally, a compass is displayed at the top left to aid orientation.

When a landmark is reached, the system outputs the message "Landmark XX reached".



### Recording a trip section (trace)

Off-road navigation allows you to record a section of a trip, even in non-digitised areas. This is done by setting navigation points ("trace points").

A section of this type is called a trace.

Traces can be recorded in off-road mode while route guidance is active.

**i** You can record and store up to 15 traces in the personal destination memory.

Traces are not stored in the list of previous destinations.

### Map view during trace recording

During trace recording, the recorded route of the trace is shown as a blue line in the map view.

### Map view when following a trace

When you drive a recorded trace, the route ahead is shown in the map in orange and the route already covered is shown in grey.

### Starting recording

1. When off-road navigation is activated, press the **NAVI** button.
2. Press the **OPTION** button or touch the tab of the same name in the header.
3. Select "**SET NAVI**"  
> "**Off-road**"  
> "**Record trace**".
4. Select "**From start point**" if you want to start recording from the start of the journey. Trace recording is continued, starting from the current point. The data automatically stored from the beginning of the journey is transferred.  
- or -  
Select "**From current position**" if you want to start recording from the current position. The data automatically stored from the beginning of the journey is deleted.

If you have already recorded a trace during the trip, deleted the trace or changed the grid for setting the navigation points, you will only be able to record a new trace using the "**From current position**" function.

**i** You can also access the "**Record trace**" and "**End trace**" functions in the option menu in the map view when off-road navigation is activated.

## Ending trace recording

1. Press the **NAVI** button while recording is underway.
2. Press the **OPTION** button or touch the tab of the same name in the header.
3. Select **"SET NAVI"**
  - > **"Off-road"**
  - > **"End trace"**.

## Storing a recording

As soon as you end a trace recording you are asked whether this trace should be stored in the destination memory.

1. Confirm the prompt that appears by selecting **"Yes"**.
2. The input menu is opened. A suggestion for a name is already provided in the input field.
3. Change the suggested name as you want and confirm your entry by selecting **"OK"**.

## Setting the grid for automatic setting of the navigation points

You can set the intervals at which the so-called trace points are set during trace recording:

- **"Optimised"**

The navigation system automatically generates a navigation point at geometrically practical locations in order to record the trace.
- **"Set ... mi"**

The number of navigation points set by the system depends on the frequency of the changes in direction.

Here you define at what point in the driven route a navigation point is to be set during trace recording. The navigation points are set regardless of any changes in direction.

Up to 1,000 trace points per trace are set during recording. The setting chosen when setting the points determines the maximum route that can be recorded.

The memory remaining for the active recording is displayed in the map.

1. When off-road navigation is switched on, press the **NAVI** button.
2. Press the **OPTION** button or touch the tab of the same name in the header.
3. Select **"SET NAVI"**
  - > **"Off-road"**
  - > **"Off-road settings"**.
4. Select **"Recording mode"**.
5. Set the grid you want by selecting it.

## Setting trace points manually

You can also set trace points manually during trace recording.

1. Press the **NAVI** button while trace recording is underway.
2. Press the **OPTION** button or touch the tab of the same name in the header.
3. Select **"SET NAVI"**
  - > **"Off-road"**
  - > **"Set trace point"**.

## Tracing a route

You have various options when tracing routes, based on the trace direction (**"Trace forward"** and **"Trace backward"**) and trace point (**"From start point"** and **"From current position"**):

- From start point, trace forwards:

You are directed to the start point of the recording and drive the trace from the start point to the end point.
- From start point, trace backwards:

You are directed to the end point of the recording and drive the trace from the end point to the start point.
- From current position, trace forwards:

You are directed to the closest point in the trace and drive the trace in the direction of the end point.
- From current position, trace backwards:

You are directed to the closest point in the trace and drive the trace in the direction of the start point.

After starting navigation, you are navigated to the next navigation point. Route guidance is by means of a compass display with the vehicle symbol in the centre of the compass rose.

The orange-coloured arc segment points in the direction of the navigation point currently being navigated to. The angular deviation between the current direction of travel and the direction to the next navigation point is shown as an orange-coloured segment. The angular deviation is indicated in degrees.

1. Press the **NAVI** button.
2. Select **"Stored destinations"**.  
The personal destination memory is opened.
3. Select the trace you want in the list.
4. Select **"Start route guidance"**.  
If off-road navigation is not yet activated, the safety notice is displayed.
5. Confirm the safety notice with **"Activate „off-road"**" if applicable to activate off-road navigation.
6. Select the direction of travel you want and the start point you want along the route to be driven.  
Route guidance is started.

## Reloading data

### Changing the navigation database

If the selected destination lies outside of the current navigation database, a route is calculated to a point that is close to the destination entered and is located within the database. Route guidance from this point is interpreted as off-road route guidance, as there is no map data available. If there is additional map data available on the PCM, this can be reloaded.

- i** If a selected destination lies outside of the current database and there is a geographical coordinate saved for this destination, route guidance to this destination can be started.
1. Press the **NAVI** button.
  2. Press the **OPTION** button or touch the tab of the same name in the header.
  3. Select **"SET NAVI"**
    - > **"Re-load data"**
    - > **"Database switch"**.  
A list of the available databases is opened.
  4. Select the required database in the list.
  5. Confirm the prompt that appears and perform the database search by selecting **"Yes"**.

# MAP

Changing the scale of the map.....	149
Moving the map.....	149
Setting 3D display.....	149
Displaying traffic messages.....	149
Setting the display of the total route.....	150
Setting autozoom.....	150
Displaying Destination town/Location.....	150
Operating the map menu using symbols.....	150
Displaying sections of the route.....	151
Setting the display layout.....	151
Switching between different layouts.....	151
Compiling map contents.....	152
Compiling the map information.....	152
Compiling the points of interest to be displayed.....	153

You call up the map view of the navigation system by pressing the **MAP** button.

Your vehicle is shown in the map view as a triangular arrow. The arrowhead points in the direction of travel. The centre of the vehicle is represented by the black dot in the middle of the small triangle. The recommended driving route, streets, rivers, railroad tracks, wooded areas or lakes are displayed as coloured lines or areas.

The detail depends on the map scale set.

When route guidance is active, either the expected time of arrival or the remaining trip time in hours and distance from destination are displayed at the bottom of the display. You can switch back and forth between the two options by briefly touching the display.



You can choose for yourself the content shown in the map view. To find out more, please refer to the section „COMPILING MAP CONTENTS“ on page 152.

**i** You can also call up and operate the map view menu using symbols. To find out more, please refer to the section „OPERATING THE MAP MENU USING SYMBOLS“ on page 150.

## Changing the scale of the map

The current scale is shown in the bottom right of the map in the map display.

▷ Set the map scale you want by turning the right rotary knob .

A number of map views also display the two symbols  and .

▷ Change the map scale you want by touching the two symbols on the display.

## Moving the map

You can move the map section shown on the display as you want. You have two options for doing this:

▷ Briefly touch the display to move the map section so that the centre point of the map is at the point you touched.

- or -

▷ Touch and hold a point in the map view to keep moving the map in the direction of this point. The map will keep moving until you stop touching the screen.

## Setting 3D display

If this function is activated, a three-dimensional map view is shown.

1. Press the **MAP** button.

2. Call up the map view menu by pressing the right rotary knob .

3. Select “**Bird’s-eye view**” to activate  or deactivate  the function.

## Displaying traffic messages

When this function is activated, traffic information is also shown in the map view.

1. Press the **MAP** button.



2. Call up the map view menu by pressing the right rotary knob .

3. Select “**Show traffic**” to activate  or deactivate  the function.

## Setting the display of the total route

If you have activated this function, the total route from the vehicle position to the destination flag is displayed during route guidance.



The map scale is automatically adapted.

1. Press the **MAP** button.
2. Call up the map view menu by pressing the right rotary knob .
3. Select **"Total route"** to activate  or deactivate  the function.

## Setting autozoom

If you have activated this function, the entire current route section is displayed.

As soon as you leave the current route section, the next route section is displayed in the map. The map scale is calculated and dynamically adapted according to the length of the new route section.

1. Press the **MAP** button.
2. Call up the map view menu by pressing the right rotary knob .
3. Select **"Autozoom"** to activate  or deactivate  the function.

## Displaying Destination town/ Location

When route guidance is active, selecting the **"Show destination"** or **"Show location"** function displays the relevant position in accordance with the zoom functions currently active.

1. Press the **MAP** button.
2. Call up the map view menu by pressing the right rotary knob .
3. Select **"Show destination"**.  
The destination town is displayed on the map.
4. If necessary, select **"Show location"**.  
The current location of the vehicle is displayed on the map.





## Operating the map menu using symbols

If you have activated the **"Map menu"** menu item in the map display, you can also operate the map menu functions by touching the corresponding symbols on the display.

To find out more, please refer also to the section „COMPILING THE MAP INFORMATION“ on page 152.

1. Press the **MAP** button.
2. Touch the symbol for the map menu  on the display.

The following symbols are displayed:





-  Switch three-dimensional map view on/off
-  Show/hide traffic messages
-  Switch display of the total route on/off
-  Switch autozoom on/off
-  Switch between location map and destination map

3. To activate or deactivate a menu item, briefly touch the menu item on the display.

 When menu items are activated, the corresponding symbols are displayed in orange.

## Displaying sections of the route

If you have started the route guidance component of your navigation system, a list containing all sections of your route will be displayed.

1. Press the **MAP** button.
2. Press the **OPTION** button or touch the tab of the same name in the header.
3. Select **"Route list"**.  
The sections of your route are listed and displayed.  
The section you are currently driving on is at the very top of this list and the final destination at the very bottom.
4. Select the section you want for a more detailed view.  
You then see a map section showing the route section in question.
5. You can adjust the map scale by touching the two symbols  and , as well as scroll through the various sections by touching the symbols  and .
6. If you wish to detour around this section of your route, select **"Detour"**.  
To find out more about setting detours, please refer to the section „SETTING A DETOUR“ on page 136.

-  This function is also available under the **"Route list"** menu item in the **INFO** menu. If off-road navigation is activated, a restricted version of this function is available with so-called landmark navigation.

## Setting the display layout

You have four options for dividing the display while route guidance is active:

- **"Full screen map"**  
The map is shown across the entire display.
  - **"With guidance"**  
In addition to the relevant map section, the next driving instruction is shown in the right half of the display.
  - **"With direction list"**  
In addition to the relevant map section, the next manoeuvre is shown with the help of pictograms.
  - **"With route preview"**  
In addition to the map section containing the current position, a further map section containing the route ahead is shown.
1. Press the **MAP** button.
  2. Press the **OPTION** button or touch the tab of the same name in the header.

3. Select **"SET MAP"**  
> **"Map layout"**.  
The various options for the display layout are shown.
4. Select the layout you want.  
The chosen layout is set.

## Switching between different layouts

- ▷ If you choose the **"With guidance"**, **"With direction list"** or **"With route preview"** layout, you can switch to the full-screen map by briefly touching the right half of the display.  
The driving instructions are then shown in a small window in the top left corner of the display.
- ▷ In the **"Full screen map"** layout, you can switch to the previously set split screen layout by briefly touching the so-called mini driving instructions in the top left corner.



## Compiling map contents

You can adapt the map view to your requirements by selecting various elements and settings.

### Compiling the map information

1. Press the **MAP** button.
2. Press the **OPTION** button or touch the tab of the same name in the header.
3. Select **"SET MAP"**  
> **"Map view"**.

The following map display criteria are then available to you:

- **"Junction zoom"**  
When this function is activated, the upcoming driving manoeuvre (e.g. leaving the motorway) is displayed greatly enlarged during route guidance.
- i** If you press the Back button  while a driving manoeuvre is shown in enlarged form, the enlarged view is cancelled. However, the function remains active. Pressing the Back button  again reactivates the enlarged display.

**i** If you have activated the **"Junction zoom"** function and an upcoming driving manoeuvre is displayed in enlarged form, it is not possible to display another function such as **"Show destination"** at this point.

- **"Bird's-eye view"**  
When this function is activated, a perspective map view is displayed.
- **"3D terrain model (for bird's-eye view)"**  
When this function is activated, a 3D terrain model is displayed.
- **"3D buildings"**  
When this function is activated, a 3D town model is displayed when the 3D map is activated.
- **"3D POIs"**  
When this function is activated, the 3D points of interest are only displayed in the 3D map.
- **"Satellite image"**  
When this function is activated, a satellite image is displayed to a scale of over 50 km (approx. 31 miles).
- **"Speed limit"**  
When this function is activated, speed limits are displayed in the driving instructions (see CAR).

### WARNING

**Accident hazard. The navigation system is only intended as an aid to the driver. This does not release you from your full responsibility for observing road safety, traffic conditions, legal road traffic regulations and any other relevant regulations while driving your vehicle.**

**Road signs en-route should always be heeded. The speed limit displayed by the PCM may not always be correct.**

**As the driver, you must assess the particular speed limit. You have sole responsibility for road safety while driving your car.**

▷ Continue to heed road signs en-route.

- 
- **"Show traffic"**  
When this function is activated, the traffic messages are displayed in the map view.
  - **"Guidance"**  
When this function is activated, driving instructions are displayed in the form of arrow symbols.
  - **"Footer (station/track)"**  
When this function is activated, the footer is also shown in the map view.



– **“Map menu”**

When this function is activated, a symbol is displayed in the map view that gives you access to all of the functions of the map menu.

– **“North arrow”**

When this function is activated, a north arrow is displayed.

– **“North orientation”**

When this function is activated, the map will be oriented to the north. If the **“Bird’s-eye view”** option is active, the **“North orientation”** option has no function.

– **“Day/night switchover”**

The following options are available for you to select:

– **“Automatic”**

The map view automatically switches from day design to night design as a function of the vehicle lighting.

– **“Day”**

The map view always remains set to the day design colours. This means the display colours are optimised for legibility.

– **“Night”**

The map view always remains set to the night design colours. The display colours are dimmed to prevent glare.

– **“Display arrival time”**

You can choose whether the estimated **“Arrival time”** or the **“Remaining time”** is to be displayed in the map view.

4. Select the various list items to show (☑) or hide (☐) them in the map view.

The map view is adapted in accordance with your settings.

### **Compiling the points of interest to be displayed**

1. Press the **MAP** button.

2. Press the **OPTION** button or touch the tab of the same name in the header.

3. Select **“SET MAP”**

> **“Show POIs”**.

The list containing the various point of interest categories is displayed.

4. Select the point of interest category you want. The list containing the associated subcategories is displayed.

5. Select the various subcategories to show (☑) or hide (☐) them in the map view.

The map view is adapted in accordance with your settings.

# Voice control

How voice control works .....	155
Incorrect operation and cancelling a dialogue.....	155
Functions of the button on the stalk for direction indicators, high beam and headlight flasher .....	155
Speech intelligibility .....	155
Symbols in sample dialogues.....	156
Commands.....	156
Local commands .....	156
Global commands .....	156
Voice entries .....	157
Basic voice control functions .....	157
Activating voice control.....	157
Deactivating voice control.....	157
Setting the volume .....	158
Setting the language .....	158
Configuring the voice control system .....	158
Performing voice adaptation.....	159
Using the help function .....	159
Operating lists using voice control .....	160
Operating examples .....	161
Operating example for radio mode.....	161
Operating example for TV tuner .....	163
Operating example for CD/DVD mode.....	164
Operating example for iPod mode.....	165
Operating example for telephone mode.....	166
Operating example for navigation mode .....	169
Operating example for map.....	172

### **Please refer to the information on operation and road safety on page 5.**

The PCM is fully voice controllable (with the exception of the functions in the **CAR** and **SOUND** menus as well as the various SET menus).

The voice control system is designed so that you can generally say **each** menu item shown on the display. Exceptions are indicated by an appropriate message on the display of the PCM.

Voice control is activated by pressing the button on the stalk for the direction indicators, high beam and headlight flasher (please see also „ACTIVATING VOICE CONTROL“ on page 157).

This allows you to operate the PCM without taking your hands from the steering wheel.

### **How voice control works**

The voice control system recognises commands or numerical sequences regardless of the speaker. It provides acoustic feedback and guides you through the functions.

### **Incorrect operation and cancelling a dialogue**

If you say an incorrect or unavailable command, the voice control system responds with “Could you repeat that?” and you can repeat the command. After the 2nd failed attempt, the system offers assistance; after the 3rd failed attempt, the PCM aborts the operation and terminates the dialogue with “End”.

You have the following options for terminating voice control during a dialogue:

- ▷ Say “cancel” when the voice control system is expecting a command.
- ▷ Say “End” when the voice control system is expecting a command.
- ▷ Press any button on the PCM. The PCM then executes the function corresponding to the pressed button.
- ▷ The only exception to this is the volume control. You can only use this button to adapt the volume of the announcements, not to terminate a dialogue.

### **Functions of the button on the stalk for direction indicators, high beam and headlight flasher**

By pressing the button on the stalk for direction indicators, high beam and headlight flasher you can:

- terminate a voice control announcement while it is in progress,
- skip to the next part of the announcement in the case of announcements with multiple parts,
- cancel a dialogue manually.

The button has no function during a telephone call.

### **Speech intelligibility**

To make it easier for your voice control system to understand your commands, please note the following points:

- The hands-free microphone is directed towards the driver’s seat. The voice control system should therefore be operated by the driver.
- Do not speak while your voice control system is making an announcement.
- Speak without interruptions and at a normal volume. Avoid long pauses and excessive emphasis.
- Reduce background noise by closing the windows, doors and sunroof.
- While giving voice commands, avoid other noise in the vehicle (e.g. passengers speaking among themselves).

#### **WARNING**

**Accident hazard Since stressful situations can cause your voice to change, it may happen that a telephone connection you want is not established quickly enough.**

- ▷ Do not use the voice control system to operate the telephone in cases of emergency.

For safety reasons, an **emergency call can only be initiated directly** on the device.

---

## Symbols in sample dialogues

A number of the voice commands initiate dialogues between you and the voice control system. A few of these dialogues are presented in the operating manual as examples.

The following symbols are used in the sample dialogues:

🗨️ symbol

This symbol identifies a voice command spoken by you.

🔊 symbol

This symbol identifies an announcement made by the PCM.

🗨️ symbol

This symbol identifies a message shown on the PCM display.

Beep🔊 symbol

This symbol identifies the audible signal that sounds as soon as the PCM is ready to accept a command.

## Commands

The commands supported by your voice control system are divided into two categories:

### Local commands

Local commands can only be spoken within the respective main function. They are not listed here since they include all menu items shown on the display. The only exceptions are the **CAR** and **SOUND** menus as well as the various SET menus. These are not voice controllable.

Voice control for lists is different and is described in the section „OPERATING LISTS USING VOICE CONTROL“ on page 160.

### Global commands

Global commands can be spoken in any function. They include:

- the main functions of your PCM,
- selected shortcuts (branching directly to a function without opening its main function beforehand) as well as
- the various help topics.

Global commands for the voice-controlled main functions:

- Tuner, radio
- Media, Disc, CD
- phone, Telephone
- info
- navi, Navigation
- map

Global commands for the non-voice-controlled main functions:

- sound
- car

Global commands related to the telephone:

- call, phone
- call name, make call to name
- Dial number

Global commands related to navigation:

- go to destination, go to destination ...\*
- begin route guidance
- cancel route guidance
- enter address
- input country
- input town
- input street
- input junction
- go home
- go to office
- search ATM
- search hotel
- search restaurant
- search petrol station

Global commands for the help function:

- help
- help voice control
- help devices
- help source
- help tuner
- help media, help disc
- help phone, help telephone
- help info
- help navi, help navigation
- help map
- help option

Other global commands:

- source
- traffic messages
- set TP
- deactivate set TP
- traffic messages, show traffic messages, Read out traffic messages on route
- cancel, end
- back

## Voice entries

You can assign so-called voice entries for entries in the phonebook as well as for destinations in your personal destination memory.

These voice entries are intended to make it easier for you to call up people or places with names that are difficult to understand (e.g. foreign names).

You can assign 20 voice entries each for the phonebook and destination memory.

**i** Please note that recognition of the voice entries depends on the language currently selected for the voice control system.

Therefore, always use the language that you wish to use for voice control when creating the voice entries.

If you change the language, the system may no longer reliably recognise the voice entries that you have trained it for in another language.

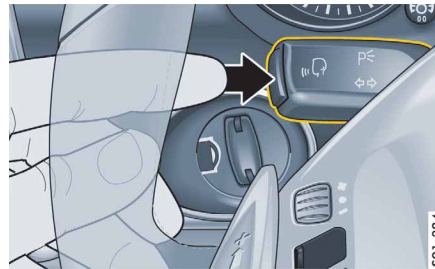

Panamera



Cayenne

## Basic voice control functions



### Activating voice control

You cannot activate the voice control system while you are on a telephone call.

1. Switch on the ignition and the PCM.
2. Press the button on the stalk for the direction indicators, high beam and headlight flasher.

An audible signal sounds after a short time, the voice control system is activated and awaits a spoken command. If you do not say a command, the voice control system prompts you to speak with the request, "Could you repeat that?".

As soon as the voice control system is activated, you will see one of the following symbols at the top right of the display:

-  = The voice control system is awaiting a spoken command.
-  = The voice control system is currently making an announcement.

### Deactivating voice control

You can deactivate the voice control system as follows:

- ▷ Press the button on the stalk for the direction indicators, high beam and headlight flasher.

- or -

- ▷ Say "cancel" or "end" when the voice control system is expecting a command.

After the system is deactivated, you will hear a confirmation announcement of "End", after which the voice control system switches off.



Sports cars

### Setting the volume

You can change the volume of the voice control system announcements to compensate for changes in the ambient noise during the journey, for example.

1. Activate the voice control system and say a command such as “help”.
2. Turn the volume control on your device during an announcement to raise or lower the volume of the announcement.

**i** The volume of the voice control system announcements is independent of that of the telephone and audio system.

### Setting the language

The voice control system recognises various languages. When you change the language, it affects voice input by the user, voice output by the PCM and the language shown on the display.

### Selecting the language yourself

1. Press the **CAR** button.
2. Press the **OPTION** button or touch the tab of the same name in the header.
3. Select “**SET PCM system**” > “**Language PCM**”.
4. Select the language you want.

### Adapting the language to the instrument cluster

1. Press the **CAR** button.
  2. Press the **OPTION** button or touch the tab of the same name in the header.
  3. Select “**SET PCM system**” > “**Language PCM**”.
  4. Select “**Automatic**”.
- The language of the instrument cluster is set.

**i** If the language of the instrument cluster is not available as a language in the PCM, the language “**English GB**” is set.



### Configuring the voice control system

You can configure how you interact with the voice control system in just a few steps.

1. Press the **CAR** button.
2. Press the **OPTION** button or touch the tab of the same name in the header.
3. Select “**SET PCM system**” > “**Voice control**”.

The following options are then available for you to select:

#### – “Repeat”

The voice control system repeats all recognised commands. You can switch off this repetition. Switching it off makes using the voice control system faster but this comes at the expense of not knowing whether the voice control system has correctly recognised the command given.

Voice entries and digits are always repeated, even if the function is switched off.

#### – “Quick dialog”

If you activate this function, the PCM outputs certain announcements in an abridged form. This does not change the information content of the announcements. This option is useful for experienced users.

#### – “Show hints”

This function is switched on at the factory. If it is switched on and voice control is activated, the PCM shows you commands that are available in addition to the menu items already shown.

4. Select to activate () or deactivate () the respective function.

### Performing voice adaptation

The voice adaptation function allows you to individually adapt the voice control system to your voice, thereby improving the voice recognition. This does not impair the recognition of other users.

**i** Adaptation can only be performed when the vehicle is stationary. Please note the first five points in the section „SPEECH INTELLIGIBILITY“ on page 155 in connection with this.

### Starting/cancelling voice adaptation

1. Press the **CAR** button.
2. Press the **OPTION** button or touch the tab of the same name in the header.
3. Select “**SET PCM system**”  
> “**Voice control**”  
> “**Voice adaptation**”.
4. Select “**Start adaptation**”.  
Adaptation starts and commences interaction with the user.
5. Follow the instructions of the PCM and repeat each command and numerical sequence after the tone.  
Adaptation ends automatically after the last command and the data is automatically stored.
6. Select “**Cancel**” to abort the adaptation.  
In this case no data is stored.

### Deleting voice adaptation

1. Press the **CAR** button.
2. Press the **OPTION** button or touch the tab of the same name in the header.
3. Select “**SET PCM system**”  
> “**Voice control**”  
> “**Voice adaptation**”.
4. Select “**Delete adaptation**”.
5. Select “**Yes**” or “**No**”.  
The adaptation is deleted or not deleted depending on your selection.

## Using the help function

### Help functions in the PCM

The voice control system features an integrated help function with commands that are always available. You will find an overview of the commands in the section „GLOBAL COMMANDS”, subsection „GLOBAL COMMANDS FOR THE HELP FUNCTION:“ on page 156.

Below you will find a brief description of the most important help commands.

#### – “help” command:

When you say this command, the PCM reads out the commands available for the menu items currently shown. It also tells you the commands to use to obtain further help.

#### – “help voice control” command:

This command interactively guides you to the help you need using the available help topics and help areas.

#### – “help devices” command:

After this command, the PCM prompts you for the main function on which you need help, for example tuner or media. You are then interactively guided to the help you want using the available help topics and help areas.

- “help” command, followed by a main function, e.g. “Media”:  
This command allows you to skip the step of specifying the main function for which you need help. It brings you directly to the help for a specific main function.

Like the voice control system, you can also deactivate the help. To find out how to do this, please refer to the section „DEACTIVATING VOICE CONTROL“ on page 157.

### Help texts in the instrument cluster

During a dialogue between you and the voice control system, information, voice-controlled commands and lists are displayed in the instrument cluster of your vehicle.

To find out more, please refer also to the corresponding chapter in the owner’s manual.



### Operating lists using voice control

#### Scrolling in a list

You can scroll through any list using the commands “scroll down” and “scroll up”.

#### Voice-controlled lists

If you see the  symbol to the right of a list entry, it means that the list is voice controllable.

You have the following options for selecting a row in voice-controlled lists:

- ▷ Saying the contents as they are displayed in the row.

- or -

- ▷ Say the command “line number”, directly followed by the number you see on the right end of the row.

### Non-voice-controlled lists

With non-voice-controlled lists, you can only select a row using the row number.

- ▷ Say the command “line number”, directly followed by the number you see on the right end of the row.

### Reading out list contents

In voice-controlled lists you can have the list contents read out. The PCM starts with the highlighted list row and reads out the list down to the last row.

- ▷ Say the command “read out”.





## Operating examples

The voice control system is designed so that you can say each menu item shown on the display. If you activate the “Show hints” function, exceptions are indicated by an appropriate message on the display of the PCM.

The PCM also shows you the most relevant commands possible at that time as soon as you are prompted to enter a command. To find out more, please refer to the section „CONFIGURING THE VOICE CONTROL SYSTEM“ on page 158.

Due to the large number of control options, we have chosen to provide a number of operating examples on the following pages instead of a full listing of all voice-controlled functions.

## Operating example for radio mode

### Calling up radio mode and switching waveband

▷ Activate voice control.

◀ Beep 6

🔊 “Tuner”.

◀ “Tuner”.

The PCM switches to radio mode if another mode was active prior to the command being entered. If radio mode was already active, the waveband is switched.

### Selecting the preset memory

You can select a preset memory directly. Do this by saying the command “preset memory FM 1”, for example.

### Tuning to a currently receivable FM station

If you know the currently receivable FM stations and if radio mode is your active audio source, you can tune to the station you want by saying its name.

▷ Activate voice control.

◀ Beep 6

🔊 “Station BBC Radio 3”.

◀ “Station BBC Radio 3”.

The PCM tunes to the corresponding station.

## Tuning to stored FM stations

You can either say the name of a stored station from the FM main menu or the number of the corresponding memory location.

▷ Activate voice control.

◀ Beep 6

🔊 “Station BBC Radio 3”.

◀ “Station BBC Radio 3”.

- or -

▷ Activate voice control.

◀ Beep 6

🔊 “Station number 1”.

◀ “Station number 1”.

The PCM tunes to the corresponding station.

## Tuning to stored AM stations

You can say the memory location of a stored station from the AM main menu.

▷ Activate voice control.

◀ Beep 6

🔊 “Station number 1”.

◀ “Station number 1”.

The PCM tunes to the corresponding station.

## Entering a frequency

You can also tune to FM and AM stations by entering the frequency. The frequency input menu only accepts frequencies within the given waveband:

- FM waveband: 87.5 - 108.0 MHz, with 0.5 MHz increments.
- AM waveband: 531 kHz - 1620 kHz, with 1 kHz increments.

Example for entering the frequency 98.4 MHz in the FM waveband:

- ▷ Activate voice control.
- ◄ Beep
- : “Manual tune”.
- ◄ “Manual tune”.
- The display switches to the frequency input menu.
- ◄ “Please say the desired frequency”.
- Beep
- : “Ninety-eight point four”.
- ◄ “Frequency Ninety-eight point four megahertz”.
- The PCM tunes to the corresponding frequency; the frequency input menu stays open.

With the command “frequency” directly followed by the MHz frequency you want, you can enter a frequency without the display changing to the frequency input menu.

## Station search

You can use the commands “next station” and “previous station” to start the station search in the FM or AM waveband. The search scans upwards or downwards and automatically stops at the next receivable station.

### Automatic station search (autostore)

The automatic station search fills the memory of the preset memory currently selected with the six stations with the strongest reception signal at the present time.

Any stations that have already been stored (e.g. manually stored) are overwritten.

This function is not available for preset memories BEST FM and MIXED.

Example for entering an autostore in the preset memory FM1:

- ▷ Activate voice control.
- ◄ Beep
- : “Autostore FM1”.
- ◄ “Autostore FM1”.
- The PCM starts the function.

### Starting/stopping the scan function

If you activate this function, each station found within the frequency range will be played for approx. 5 seconds.

- ▷ Activate voice control.
- ◄ Beep
- : “Start scan”.

- ◄ “Start scan”.
- The PCM plays the stations one after the other.
- ▷ Activate voice control.
- ◄ Beep
- : “Stop scan”.
- ◄ “Stop scan”.
- The PCM tunes to the station currently playing.

### Switching the traffic programme on/off

Switch the traffic programme on and off using “set TP” and “deactivate set TP”.

### Tuning to stations from the station list

The station list is available in the FM waveband and contains all currently receivable stations.

- ▷ Activate voice control.
- ◄ Beep
- : “Station list”.
- ◄ “Station list”.
- The station list is displayed.
- ▷ Scroll through the list using the commands “scroll down” or “scroll up” until you find the station you want.

The following two options are available to you for tuning to a station:

🗣️: “Station BBC Radio 3”.

👉: “Station BBC Radio 3”.

The PCM tunes to the station BBC Radio 3.

- or -

🗣️: “Line number 3”.

👉: “Line 3”.

The PCM tunes to the corresponding station.

**i** You can also tune to a station from the station list directly without calling up the list first. Say the “Station” command, directly followed by the name of the station as it appears in the list.

The station list is a voice-controlled list; to find out more about this please refer also to the section „OPERATING LISTS USING VOICE CONTROL“ on page 160.

## Operating example for TV tuner

### Calling up TV mode

▷ Activate voice control.

👉: Beep ⚡

🗣️: “Tuner TV”.

👉: “Tuner TV”.

The PCM switches to TV mode.

### Selecting the preset memory

You can select a preset memory directly. Do this by saying the command “preset memory TV 1”, for example.

### Station search

You can use the commands “next station” or “previous station” to start the station search. The search scans upwards or downwards and automatically stops at the next receivable station.

### Tuning to stations from the station list

The station list contains all the stations that can currently be received.

▷ Activate voice control.

👉: Beep ⚡

🗣️: “Read out station list”.

👉: “Read out station list”.

The stations are read out one after the other.

The following two options are available to you for tuning to a station:

🗣️: “Station BBC1”.

👉: “Station BBC1”.

The PCM tunes to BBC1.

- or -

🗣️: “Line number 3”.

👉: “Line 3”.

The PCM tunes to the corresponding station.

### Calling up video text pages

▷ Activate voice control.

👉: Beep ⚡

🗣️: “Video text”.

👉: “Video text”.

Video text appears.

The following two options are available to you for opening a video text page:

🗣️: “next page”.

👉: “next page”.

The PCM opens the page.

- or -

🗣️: “Page 333”.

👉: “Page 333”.

The PCM opens the corresponding page.

## Operating example for CD/DVD mode

### Calling up CD/DVD mode

▷ Activate voice control.

◀ Beep 

: “Disc”.

◀ “Disc”.

The PCM switches to disc mode.

### Selecting a track from the track list

The track list contains all the tracks on the CD/DVD currently being played.

▷ Activate voice control.

◀ Beep 

: “Track list”.

◀ “Track list”.

The track list is displayed.

Selecting a track from the track list:

▷ Scroll through the list using the commands “scroll down” or “scroll up” until you find the track you want.

: “Line number 3”.

◀ “Line 3”.

The PCM plays the corresponding track.

 If the disc currently playing is an MP3 CD/DVD, the track list shows the names of the root directories as well as the subdirectories. You can also choose folders and playlists using the “line number” command, directly followed by the corresponding number. The track list is a non-voice-controlled list; to find out more about this please refer also to the section „OPERATING LISTS USING VOICE CONTROL“ on page 160.

### Choosing a track by skipping

You can skip to the previous or next track using the “previous track” and “next track” commands respectively.

### Choosing a track by entering the track number

You can select a track directly in CD/DVD mode using the “track number” or “track” command, directly followed by the corresponding number.

### Choosing a disc using the disc list

The disc list contains all available CDs/DVDs.

▷ Activate voice control.

◀ Beep 

: “Disc selection”.

◀ “Disc selection”.

The disc list is displayed.

◀ “Please say the number of the required disc”.

: “Disc number 3”.

◀ “Disc number 3”.

The PCM plays the corresponding CD/DVD.

 The disc list is a non-voice-controlled list; to find out more about this please refer also to the section „OPERATING LISTS USING VOICE CONTROL“ on page 160.

### Choosing a CD/DVD by entering the disc number

You can select a specific disc directly using the “Disc number” command, directly followed by the corresponding number.

### Repeating a track

When this function is activated, the current track or chapter (video DVD mode) is repeated.

Activate and deactivate the repeat function using the “activate repeat” and “deactivate repeat” commands.

### Switching the shuffle function on/off

When this function is activated, the PCM plays the tracks on the disc currently playing in random order.

Activate and deactivate the shuffle function using the “activate shuffle” and “deactivate shuffle” commands.

### Scanning tracks

When this function is activated, the PCM plays a brief snippet of each track on the disc currently playing in sequence.

Start and stop the scan function using the “Start scan” and “Stop scan” commands.

## Operating example for iPod mode

### Calling up iPod mode

- ▷ Activate voice control.

◀ Beep 

 "Media iPod".

◀ "Media iPod".

The PCM switches to iPod mode.

### Selecting a track from the track list

- ▷ Activate voice control.

◀ Beep 

 "Track list".

◀ "Track list".

The track list is displayed.

 The iPod determines the sorting of the lists.

Selecting a track from the track list:

- ▷ Scroll through the list using the commands "scroll down" or "scroll up" until you find the track you want.

 "Line number 3".

◀ "Line 3".

The PCM plays the corresponding track.

### Choosing a track by skipping

You can skip to the previous or next track using the "previous track" and "next track" commands respectively.

### Choosing a track by entering the track number

You can select a track directly in iPod mode using the "track number" or "track" command, directly followed by the corresponding number.

### Repeating a track

Activating this function repeats the current track. Activate and deactivate the repeat function using the "activate repeat" and "deactivate repeat" commands.

### Switching the shuffle function on/off

When this function is activated, the PCM plays the tracks in the track list in random order. Activate and deactivate the shuffle function using the "activate shuffle" and "deactivate shuffle" commands.

### Searching for music

You can start a music search in iPod mode based on the following criteria:

- Artists,
- albums,
- track and
- music genres.

Below is an example of how to perform a search for the tracks of a specific artist.

- ▷ Activate voice control.

◀ Beep 

 "Find music".

◀ "Find music".

 "Artists".

◀ "Artists".

A list of all the artists whose tracks are stored on the iPod is displayed.

- ▷ Scroll through the list using the commands "scroll down" or "scroll up" until you find the track you want.

 "Line number 3".

◀ "Line 3".

 "activate repeat".

The PCM plays the corresponding track.

## Operating example for telephone mode

### ⚠ WARNING

**Injury hazard. In emergency situations, stress may cause your voice to change to an extent where it might take longer than normal to establish a telephone connection.**

- ▷ Do not use the voice control system in cases of emergency.

**Injury hazard. The telephone must not be used near explosives or flammable materials (e.g. at a petrol station) or near operations involving explosives.**

**Mobile phones must be switched off in certain hazardous areas such as near petrol stations, fuel depots, chemical plants and demolition work in progress using explosives, for example. They can interfere with technical equipment.**

- ▷ Please heed appropriate warnings.
- ▷ Observe statutory regulations and local restrictions when using the telephone.

### Calling up telephone mode

- ▷ Activate voice control.
  - ◀ Beep 
  - 📞 “Telephone”.
  - ◀ “Telephone”.
- The PCM switches to telephone mode.





### Entering the PIN

The digits “zero” to “nine” are permitted when entering the PIN. The following two options are available to you when saying the digits:

- Say all digits in a single block without a pause.
- Group and say the individual digits in blocks, for example the first three digits and then the next three digits. Leave a pause after each block and wait until the PCM has repeated the digits from the last block entered before saying the next block.

If you say the digits in blocks, you can use the “correction” command to delete the last block. The PCM then repeats the last correct block and you can continue with your input. You can delete the complete entry using the “delete” command.

If you are saying all the digits without a pause, both these commands delete the complete entry.

- ▷ Activate voice control in the PIN input menu (see above).
  - ◀ “The PIN, please.”.
  - Beep 
  - 📞 “One two three four”.
  - ◀ “One two three four”.
  - Beep 
  - 📞 “Ok”.
  - ◀ “Checking the PIN”.
- The PCM switches to telephone mode if the entered PIN is correct.

### Entering a telephone number

The digits “zero” to “nine” as well as the following words are permitted when entering the digits:

- “Star” for the \* character
- “hash” for the # character
- “plus” for the + character

When calling international telephone numbers, use the word “plus” at the beginning of the number, followed by the country code. Then enter the local area code without the first digit, and then the telephone number.

The following two options are available to you when saying the telephone number:

- Say all digits in a single block without a pause.
- Say the telephone number in blocks, leaving a pause after each block and waiting until the PCM has repeated the digits from the last block entered before saying the next block.

If you say the telephone number in blocks, you can use the “correction” command to delete the last block. The PCM then repeats the last correct block and you can continue with your input. The “delete” command deletes the complete entry.

If you are saying all the digits without a pause, both these commands delete the complete entry.

If you try to enter more than 32 digits, you will hear an announcement that the number is too long and that the last input has been deleted.

Example for an overseas call to Germany:

▷ Activate voice control.

◀ Beep 𐄂

🗨️ “Dial number”.

◀ “Dial number.”  
Beep 𐄂

🗨️ “plus four nine”.

◀ “Plus four nine”.  
Beep 𐄂

🗨️ “Seven two four eight”.

◀ “Seven two four eight”.

Beep 𐄂

🗨️ “Seven one zero”.

◀ “Seven one zero”.  
Beep 𐄂

🗨️ “Call number”.

◀ “Dialling the number.”

The PCM dials the number.

**i** The “Dial number” command is a global command and therefore also works in other modes (e. g. navigation mode). You will find other global commands in the section „GLOBAL COMMANDS“ on page 156.

### Calling up the phonebook

▷ Activate voice control.

◀ Beep 𐄂

🗨️ “Phonebook”.

◀ “Phonebook”.

☐ The phonebook is displayed as a list.

### Calling a phonebook entry

▷ Scroll through the list using the commands “scroll down” or “scroll up” until you find the entry you want.

The following two options are available to you for making a call to an entry:

1. Say the “Call” command, directly followed by the name of the entry.  
This option is global and also works outside the phonebook.

2. Say the command “line number”, directly followed by the corresponding number shown on the right end of the row.  
This option is not global and only works within the phonebook. Furthermore, unlike option 1, it does not result in direct dialling of the telephone number.

**i** If you are saying the name of a phonebook entry, please note the following:

▷ Say the name as normal, do not spell it out.

▷ If the name of a phonebook entry is in a language other than that currently set in the PCM, the voice control system may not recognise it correctly.

With phonebook entries with multiple numbers, the entry can also be directly selected by additionally speaking the category (e.g. “Mr. Smith Office”). If the specified category does not exist for this entry, the available categories are announced.

Example for option 1:

- ▷ Activate voice control.
- ◀ Beep 𐄂
- 🗣️: “Call Information”.
- ◀ “Dialing the number of Information.”  
The PCM dials the number.

Example for option 2:

- ▷ Activate voice control.
- ◀ Beep 𐄂
- 🗣️: “Line number 3”.
- ◀ “Line 3”.
- The details for the corresponding phonebook entry are displayed.
- ▷ Activate voice control.
- ◀ Beep 𐄂
- 🗣️: “Call number”.
- ◀ “Call number.”.
- “Dialling the number.”.
- The PCM dials the number.

### Assigning a voice entry for an entry in the phonebook

The command “Change pronunciation” can be used to store speech entries for entries in the telephone book of your telephone. You can use these voice entries to make a call without having to enter the other person’s number.

To store a voice entry, you must first select an entry in the phonebook containing both a name and a telephone number.

- ▷ Activate voice control.
- ◀ Beep 𐄂
- 🗣️: “Change pronunciation”.
- ◀ “Change pronunciation. Please say a name.”  
Beep 𐄂
- 🗣️: “Mr. Smith”.
- ◀ “Please say the name a second time.”  
Beep 𐄂
- 🗣️: “Mr. Smith”.
- ◀ “The pronunciation Mr. Smith has been stored.”  
The voice entry has been stored for the entry in the phonebook.

The command “delete pronunciation” is used to delete an existing speech entry.

### List of previous calls

The “Previous calls” menu provides you access to a list of the telephone numbers you have recently dialled. You can select a list entry using voice control and call it again.

- ▷ Activate voice control.
- ◀ Beep 𐄂
- 🗣️: “Previous calls”.
- ◀ “Previous calls”.

The list of previous calls is displayed.

To find out how to select a list entry and make a call, please refer to the section „CALLING A PHONEBOOK ENTRY“ on page 167.

### List of received calls

The “Received calls” menu provides you access to a list of the calls you have recently received. You can select a list entry using voice control and call it back.

- ▷ Activate voice control.
- ◀ Beep 𐄂
- 🗣️: “Received calls”.
- ◀ “Received calls”.

The list of received calls is displayed.

To find out how to select a list entry and make a call, please refer to the section „CALLING A PHONEBOOK ENTRY“ on page 167.



## Reading out text messages (with PCM telephone only)

You can use the “read out messages” command to skip to the list of text messages and have the message headers read out.

- ▷ To have the contents of a text message that is highlighted in the list read out, say the “read out details” command.
- ▷ To have the contents of an open text message read out, say the “read out” command.

## Operating example for navigation mode

### Calling up navigation mode

- ▷ Activate voice control.
  - ◀ Beep 𐀀
  - 🗨: “Navigation”.
  - ◀ “Navigation”.The PCM switches to navigation mode.

### Entering an address and starting route guidance

If the language set in the PCM and the language spoken at the destination are the same, you can say the country, town, and street as whole words. If the two languages are not the same, you must spell the town and the street. This applies to destinations in countries with more than one official language and to destinations in other countries.

- i** If route guidance had previously been started, the country is already preset. In this case, the address entry starts with the prompt “Please say the town”.
- If you would like to set another country, you must start the dialogue with the “input country” command.

- ▷ Activate voice control.
  - ◀ Beep 𐀀
  - 🗨: “enter address”.
  - ◀ “enter address”.“Please say the town”.
- Beep 𐀀
- 🗨: “London”.
- ◀ “Please say the street”.
- Beep 𐀀
- 🗨: “Whitehall”.
- i** If the named town and street were uniquely identified by the voice control system when entered for the first time, the next step is skipped and you can proceed directly to entry of the house number.
- ☐ A list of towns and/or a list of streets is displayed if necessary.
- ◀ “Please make your selection”.
- Beep 𐀀
- ▷ Scroll through the list in this case using the commands “scroll down” or “scroll up” until you find the town you want.
- 🗨: “Line number 3”.
- i** If you are unable to find the destination you want in the town or street list, you can repeat your entry by selecting the “correction” command.

- ◀ “London, Whitehall”.  
“Would you like to input a street number?”  
Beep ⤵
  - 🗨️: “Yes”.
  - ◀ “Please say the street number”.  
Beep ⤵
  - 🗨️: “One hundred and thirty two”.
  - ◀ “One hundred and thirty two”.  
“Would you like to start route guidance?”  
Beep ⤵
  - 🗨️: “Yes”.
- The PCM calculates the route.

**i** If you want to start route guidance in the centre of a town, begin the dialogue with the “input town” command. Then select the town and respond to the request for the street by saying the “Start route guidance” command.

### Entering a destination from the list of previous destinations or from the personal destination memory

The “Previous destinations” menu provides you access to a list of the last destinations to which you started route guidance.

In the “Stored destinations” menu you will find the destinations you have stored in your personal destination memory.

**i** Both lists are voice-controlled lists, to find out more about this please refer also to the section „OPERATING LISTS USING VOICE CONTROL“ on page 160.

If you want to transfer a row to the voice control system by saying the contents, please note also the following:



- You can say all other row contents as they are displayed. If the voice control system has difficulty understanding the contents, we recommend saying the number of the respective row.
- Both lists can contain rows with geographical coordinates. Example: “8° 55' 32" E 48° 51' 5" N”. You cannot select these rows by saying their contents; you must say the row number.

▷ ▷ ▷

- You can store traces in the personal destination memory. When doing so, the PCM suggests a name. You cannot select rows with these default names by saying their contents.  
If you name the trace yourself, however, you can select the row by saying its contents.
- If you know the name of the destination, you can start route guidance directly using the “go to destination ...” command.

- ▷ Activate voice control.
- ◀ Beep ⤵
- 🗨️: “Previous destinations”.
- ◀ “Previous destinations”.
- or -
- 🗨️: “Stored destinations”.
- ◀ “Stored destinations”.
- The list of previous destinations or the personal destination memory is displayed.
- ▷ Scroll through the list using the commands “scroll down” or “scroll up” until you find the destination you want.  
The following two options are available to you for starting route guidance to a destination:
  1. Say the row contents shown on the display.
  2. Say the “line number” command, directly followed by the corresponding number of the row, which shown at its right end.

Example for option 1:

- ▷ Activate voice control.
- ◀ Beep 
- 🔊 "Whitehall".
- ☐ The details for the list entry are displayed.
- ▷ Activate voice control.
- ◀ Beep 
- 🔊 "Start route guidance".
- ◀ "Start route guidance".
- The PCM calculates the route to the destination.

Example for option 2:

- ▷ Activate voice control.
- ◀ Beep 
- 🔊 "Line number 3".
- ◀ "Line 3".
- ▷ Activate voice control.
- 🔊 "Start route guidance".
- ◀ "Start route guidance".
- The PCM calculates the route to the destination.



### Searching for points of interest

The "POI" menu provides you with access to points of interest such as petrol stations, parking areas, restaurants, hotels or hospitals, for example.

The points of interest are divided into different categories to make them easier for you to find.



With the voice control system, you can select a point of interest by entering the category and subcategory as well as the search area.

Below you will see an example for entering a point of interest in the vicinity of the vehicle.

- ▷ Activate voice control.
- ◀ Beep 
- 🔊 "POI".
- ◀ "POI".
- ☐ The points of interest menu is displayed.
- ◀ "Please select the category".
- Beep 
- ☐ The category list is displayed.
- Scroll through the list using the commands "scroll down" or "scroll up" commands until you find the category you want.

The categories, like the subcategories also, can all be spoken.

You can, however, also say the number of the line containing the category you want. The row number is at the right of the row.

- 🔊 "Line number 5".
- ◀ "Line 5".
- ☐ The subcategory list is displayed.
- ◀ "Please make your selection".
- Beep 
- 🔊 "Line number 3".
- ◀ "Line 3".
- "Where would you like to search?".
- Beep 

- ☐ You see the menu for the search areas. The entered subcategory or the entered marker is shown on the left beside the "Category" menu item.





You can now enter the search area in which the PCM is to search for points of interest.

- 🔊 "Vehicle surroundings".
- ◀ "Vehicle surroundings accepted.  
Please select the destination".
- ☐ A list containing the possible points of interest is displayed.
- 🔊 "Line number 3".
- ◀ "Line 3.  
Would you like to start route guidance?".
- 🔊 "Yes".

The PCM calculates the route to the point of interest.

### Searching for a point of interest with a known category and search area

You can shorten the input for a search for a point of interest by grouping the subcategory and search area in a single command, for example.





- ▷ Activate voice control.
- ◀ Beep 
-  "Point of interest golf course near destination".
- The result list for the search is displayed.
- ◀ "Please select the destination".
- Beep 
-  "Line number 3".
- ◀ "Line 3.
- Would you like to start route guidance?".
-  "Yes".

The PCM calculates the route to the point of interest.

### Searching for a point of interest along a route



If route guidance is active, you can search the planned route for a point of interest using the "along route" command.

If route guidance is not active, you can instead search for a specific point of interest using the "in surroundings" command.

- ▷ Activate voice control.
- ◀ Beep 
-  "Search petrol station along route".
- The result list for the search is displayed.
- ◀ "Please select the destination".
- Beep 
-  "Line number 3".
- ◀ "Line 3.
- Would you like to start route guidance?".
-  "Yes".

Route guidance to the selected point of interest is started.



### Announcing traffic messages on the route

-  This function is only available during active route guidance.
- ▷ Activate voice control.
- ◀ Beep 
-  "Read out traffic messages on route".
- ◀ "Read out traffic messages on route".
- The list of traffic messages on the route is displayed.
- ◀ "A 8 direction... "
- The list of traffic messages on the route is read out, beginning with the first entry.
- The traffic message currently being read is highlighted.

-  You can also use the "read out details" command to read out the details of a traffic message as soon as it is highlighted in the list.

### Operating example for map

#### Calling up the map view

- ▷ Activate voice control.
- ◀ Beep 
-  "Map".
- ◀ "Map".
- The PCM switches to the map view.

#### Setting the map scale

You can say all of the available map scales or display your total route on the map using the "total route" command.

#### Setting 3D display

If this function is activated, a three-dimensional map view is shown.

You can activate and deactivate the function using the "activate birds eye view" and "deactivate birds eye view" commands.

#### Displaying traffic messages

When this function is activated, traffic information is also shown in the map view.

Activate and deactivate the function using the "activate show traffic" and "deactivate show traffic" commands.

#### Setting autozoom

If you have activated this function, the entire current route section is displayed.

Activate and deactivate the function using the "activate autozoom" and "deactivate autozoom" commands.

### **Setting the map orientation**

You can change the orientation of the map using the following commands:

- “activate north orientation”,
- “deactivate north orientation”,
- “show destination” and
- “show location”.

### **Repeating a navigation announcement**

If you say the “guidance announcement” command during active route guidance, the last navigation announcement is repeated.

# Index

## A

AAC-LC .....	32
Accepting a call .....	53, 66
Activating alternative routes for route guidance .....	128
Activating the entry aid .....	124
Activating the interface .....	44, 45
Activating the rain sensor .....	122
Activating the rear wiper .....	122
Adapting the volume for an external audio source .....	44
Adding destinations to personal destination memory .....	132
Alternative frequencies .....	22
Answer button .....	9
Area search .....	135
Assigning a key .....	111
Audio formats .....	32
Audio source .....	
Displaying detailed information .....	98
Selecting .....	6
Automatic call answering .....	84
Automatic station search in radio mode .....	21
Automatic station search in TV mode .....	25
Autostore (radio) .....	21
Autostore (TV) .....	25
AUX .....	44
Activating the interface .....	44
Adapting the volume .....	44
Switching to an external audio source .....	44
AUX BT .....	45
Activating the interface .....	45
Fast forward/reverse .....	46
Repeating a track .....	46
Shuffle function .....	46
Skipping tracks .....	46
Starting/stopping scanning .....	46
Switching to an external Bluetooth® audio source .....	45
Avoiding a stretch of road .....	138
Avoiding stretches of road .....	138

## B

Back button .....	8
Best FM .....	20
Best FM preset memory .....	20

Bluetooth® .....	50
Adding a new device .....	46, 62, 86, 113, 120, 134
Authorised devices .....	47, 61, 85, 113, 120, 134
Calling up Bluetooth® settings .....	46, 113, 120, 133
Connecting an authorised device with the PCM .....	47, 61, 85, 113, 120, 134
Deleting an authorised device from the list .....	47, 61, 85, 114, 120, 134
Deleting the list of authorised devices .....	47, 61, 85, 114, 120, 134
Disconnecting an authorised and connected device from the PCM .....	61
Displaying authorised devices .....	47, 61, 85, 113, 120, 134
Displaying details for the authorised device .....	47, 61, 86, 114, 120, 134
Establishing a connection from an external Bluetooth® device .....	47, 52, 62, 113, 120, 134
Renaming an authorised device .....	47, 61, 85, 114, 120, 134
Setting the profile of the authorised device .....	85
Setting visibility .....	47, 63, 86, 113, 120, 134
Settings (external Bluetooth® audio source) .....	46
Settings (logbook) .....	113
Settings (navigation) .....	133
Settings (Sport display) .....	120
Settings (telephone) .....	61, 85
Switching Bluetooth® on/off .....	46, 113, 120, 133
Switching on/off .....	51
Brightness of the display .....	15
Buttons .....	7

## C

Call forwarding .....	83
Call settings .....	83
Call volume .....	60
Call waiting .....	58, 59, 73, 84
Accepting a call .....	58, 73
Ending a connected call .....	58, 73
Rejecting a call .....	58, 73

## Calling

Dialling a number .....	54, 67
Number from the list of previous calls .....	56, 70
Number from the list of received calls .....	57, 71
Phonebook entry .....	56, 69
Calling a destination from the personal destination memory .....	132
Calling the destination .....	130
Cancelling a block .....	137
Cancelling a detour .....	137
CD/DVD .....	
Calling up the CD/DVD changer menu .....	33
Calling up the main menu .....	34
Ejecting a CD/DVD (with CD/DVD changer) .....	33
Ejecting a CD/DVD (with CD/DVD drive) .....	33
Ejecting all CD/DVDs (with CD/DVD changer) .....	33
Fast forward/reverse .....	35
Loading a CD/DVD (with CD/DVD changer) .....	33
Loading a CD/DVD (with CD/DVD drive) .....	33
Loading all CDs/DVDs (with empty CD/DVD changer) .....	33
Naming a CD .....	35
Repeating a track .....	35
Searching for a track (MP3 CD) .....	36
Searching for music (MP3 CD) .....	36
Selecting a CD/DVD .....	34
Selecting a chapter in video DVD mode .....	34
Selecting a track .....	34
Selecting a track (MP3 CD) .....	34
Setting DVD audio groups .....	35
Setting the DVD audio format .....	35
Setting the mode .....	34
Skipping to the next track .....	35
Starting/stopping scanning .....	35
Switching the shuffle function on/off .....	35
Changing the PIN .....	82
Colour (TV) .....	28
Conducting calls with the hands-free unit .....	53, 66
Conference .....	59, 73
Configuring the display .....	15
Contrast .....	28
Controls .....	7
Copyright .....	31

Cordless handset.....	89	Display.....	9	Entering the country .....	127
Accepting a call .....	89	Cleaning .....	6	Entering the junction .....	128
Call waiting (swapping) and conference .....	91	Colour touchscreen .....	9	Entering the postal code.....	128
Charging .....	89	Faults.....	6	Entering the street .....	128
Dialling a number .....	90	Operating .....	9	Entering the street number .....	128
Ending a call .....	90	Switching back on .....	15	Entering the town .....	128
Establishing an additional call .....	90	Switching off .....	15	Establishing an additional call .....	58, 72
Muting the microphone .....	90	Display faults.....	6	Extended memory .....	121
Phonebook .....	91	Displaying destination/location .....	150	External audio source (AUX) .....	44
Rejecting a call .....	90	Displaying detailed information about		Activating the interface .....	44
Settings .....	94	the audio source.....	98	Switching to an external audio source .....	44
Switching on/off .....	89	Displaying driving instructions in the map view.....	152	External Bluetooth® audio source	
Text messages (SMS).....	92	Displaying route sections.....	98	Activating the interface .....	45
Creating a template for SMS .....	80	Displaying sections of the route .....	151	Switching to an	
		Displaying speed limits in the map display .....	152	external Bluetooth® audio source .....	45
		Displaying the footer in the map view .....	152	External Bluetooth® audio source (AUX BT) .....	45
		Displaying the north arrow in the map view .....	153		
		Displaying the system version .....	16		
		Displaying the total route in the map .....	150		
		Displaying traffic messages (TMC).....	96		
		Displaying traffic messages in the map view .....	152		
		Dolby® Digital .....	32		
		DTMF tones .....	54, 67		
		DTS.....	32		
<b>D</b>		<b>E</b>		<b>F</b>	
Deleting .....	8	Editing		Fast forward/reverse .....	35, 39, 43, 46
Authorised Bluetooth		Address of a destination		Finding the cordless handset .....	87
device.....	47, 61, 85, 114, 120, 134	(list of previous destinations) .....	130	Format .....	29
Contact person (logbook) .....	111	Address of a destination		Forward/reverse	
Contents of the SIM card.....	69	(personal destination memory).....	132	AUX BT.....	46
Destination (list of previous destinations).....	130	Data from the current trip (logbook).....	109	CD/DVD .....	35
Destinations from the		Destination name of a personal destination .....	132	iPod.....	39
personal destination memory .....	133	Phonebook entry.....	69	USB.....	43
Driver (logbook).....	111	Editing an address (list of previous destinations) .....	130	Frequency entry.....	20
Key assignment in the logbook .....	112	Editing an address (personal destination memory).....	132		
Lap in the Sport display recording.....	118	Ejecting a CD .....	8		
List of authorised Bluetooth		Ejecting a DVD.....	8		
devices .....	47, 61, 85, 114, 120, 134	Ejecting CDs/DVDs.....	33		
Phonebook entry.....	69	Electronic Programme Guide (EPG) .....	27		
Recording in the Sport display .....	117	Emergency call .....	74		
Reference lap for the Sport display .....	119	End call button .....	9		
Stopovers.....	140	Ending a call .....	54, 67		
Telephone number .....	56, 57, 70, 72	Ending a lap (Sport display).....	116		
Text message (SMS).....	78	Entering a name .....	10		
Trip destination (logbook) .....	111	Entering a space.....	11		
Trip purpose (logbook).....	111	Entering an address .....	127		
Trips in the logbook.....	112	Entering an address (list of previous destinations).....	130		
vCards.....	79	Entering an address			
Deleting a destination (list of previous destinations).....	130	(personal destination memory).....	131		
Deleting a destination					
(personal destination memory).....	133				
Deleting a lap (Sport display).....	118				
Deleting characters .....	8				
Deleting entered characters.....	8				
Destination input using geographical coordinates.....	141				
Destination input using the map.....	142				
Dialling a number (telephone) .....	54, 67				
Direct dialling .....	55, 68				

<b>I</b>			
IMEI .....	81	Logbook .....	108
Individual settings (extended memory) .....	121	Activating/deactivating .....	108
Input menu		Activating/deactivating the reminder .....	108
Operating input menus .....	10	Assigning a key .....	111
Setting the layout .....	11	Changing the contact person .....	110
Interface		Changing the driver .....	109
AUX .....	44	Changing the remarks .....	110
USB .....	40	Changing the trip destination .....	109
iPod .....	37	Changing the trip purpose .....	109
Calling up the main menu .....	37	Changing the trip type .....	109
Fast forward/reverse .....	39	Continuing recording .....	110
Playlists .....	38	Creating a contact person .....	111
Repeating a track .....	39	Creating a driver .....	111
Searching for a track .....	37	Creating a new contact person .....	110
Shuffle function .....	39	Creating a new driver .....	109
Skipping to the next track .....	39	Creating a new trip destination .....	109
Switching to iPod mode .....	37	Creating a new trip purpose .....	110
Track list .....	38	Creating a trip destination .....	111
		Creating a trip purpose .....	111
		Deleting a contact person .....	111
		Deleting a driver .....	111
		Deleting a key assignment .....	112
		Deleting a trip destination .....	111
		Deleting a trip purpose .....	111
		Deleting trips .....	112
		Editing data from the current trip .....	109
		Managing lists .....	111
		Renaming a contact person .....	111
		Renaming a driver .....	111
		Renaming a trip destination .....	111
		Renaming a trip purpose .....	111
		Setting the standard trip .....	108
		Storing a refuelling stop .....	110
		Transferring data .....	112
		Viewing the list of stored trips .....	111
<b>L</b>		Lowering the exterior mirror .....	123
Landmark navigation .....	144		
Left rotary knob .....	7	<b>M</b>	
Lift handset button .....	9	Making a detour around a route section .....	136
List of previous calls .....	56, 70	Manual frequency entry .....	20
Adding to a number .....	56, 71	MAP	
Calling a number .....	56, 70	Adapting the map view .....	152
Deleting a number .....	56, 70	Changing the scale .....	149
Displaying the list .....	56, 70	Display of the total route .....	150
Sending a message to a number from the list .....	71	Displaying a 3D terrain model .....	152
Storing a number in the phonebook .....	70	Displaying a 3D town model .....	152
List of previous destinations .....	129	Displaying destination/location .....	150
List of received calls .....	57, 71	Displaying driving instructions in the map view .....	152
Adding to a number from the list .....	57, 72		
Calling a number from the list .....	57, 71	Activating alternative routes .....	128
Deleting a number from the list .....	57, 72	Adding destinations (personal destination memory) .....	132
Displaying the list .....	57, 71	Area search .....	135
Sending a message to a number from the list .....	72	Avoiding a stretch of road .....	138
Storing a number from the list in the phonebook .....	71	Calling a destination from the personal destination memory .....	132
Lists		Calling the destination .....	130
Operating using voice control .....	160	Deleting a destination .....	130, 133
Showing the first letters of the entries .....	10	Destination input using geographical coordinates .....	141
Loading a disc .....	33	Destination input using the map .....	142
Loading CDs/DVDs .....	33	Displaying the location of a destination (list of previous destinations) .....	130
Location information .....	98		
		Displaying satellite images .....	152
		Displaying sections of the route .....	151
		Displaying the footer .....	152
		Displaying the map menu .....	153
		Displaying the north arrow .....	153
		Displaying traffic messages .....	152
		Moving .....	149
		Orienting the map to the north .....	153
		Selecting display of the arrival time .....	153
		Setting 3D display .....	149
		Setting 3D points of interest .....	152
		Setting a 3D map .....	152
		Setting autozoom .....	150
		Setting display of the arrival time .....	153
		Setting the colours for the map .....	153
		Setting the display layout .....	151
		Setting the display of speed limits .....	152
		Setting the junction zoom .....	152
		Memory buttons .....	19
		Meridian Lossless Packing .....	32
		Microphone volume .....	60
		MIXED .....	20
		MIXED preset memory .....	20
		MP3 .....	32
		MP3 CD	
		Searching for a track .....	36
		Searching for music .....	36
		Selecting a track .....	34
		Muting (audio source) .....	6
		Muting (telephone) .....	53, 66
		Muting the microphone (telephone) .....	53, 66
		<b>N</b>	
		Navigation	



Displaying the location of a destination (personal destination memory).....	131
Editing an address (list of previous destinations).....	130
Editing an address (personal destination memory).....	132
Editing the name of a personal destination.....	132
Entering an address.....	127
Entering an address from the list of previous destinations.....	130
Entering an address from the personal destination memory.....	131
Entering the country.....	127
Entering the junction.....	128
Entering the street and number.....	128
Entering the town/postal code.....	128
Entering/editing a telephone number for a destination in the personal destination memory.....	132
General operation.....	126
List of previous destinations.....	129
Personal destination memory.....	131
Points of interest.....	135
Reloading data.....	147
Safety notice.....	127
Sending a destination from the personal destination memory.....	133
Setting a detour.....	136
Setting the volume of the announcement.....	127
Starting route guidance.....	128
Starting route guidance with route alternatives activated.....	128
Stopovers.....	139
Stopping route guidance.....	128
Storing a destination (off-road navigation).....	142
Storing a destination from the list of previous destinations in the personal destination memory.....	130
Storing a position (off-road navigation).....	142
Network selection.....	81
<b>O</b>	
Off-road navigation.....	143
Activating/deactivating.....	143
Landmark navigation.....	144
Recording a trip section (trace).....	145
Safety notice.....	144
Storing a destination.....	142
Storing a position.....	142
Tracing a route.....	146

Opening the CD/DVD changer menu.....	8
Opening the changer menu.....	8
Opening the rear blind automatically.....	123
Operating.....	7
Operating lever for the on-board computer.....	157
Options for route guidance.....	136
Orienting the map to the north.....	153

## P

ParkAssist.....	102
Closing the display.....	104
Switching the display on/off.....	103
Parking with the rear view camera display.....	106
PCM USB port.....	37
Performing voice adaptation for the voice control system.....	159
Personal destinations.....	131
Personal Identification Number (PIN).....	65
Personal trip data.....	100
Phonebook.....	55, 69
Calling an entry.....	56, 69
Creating and storing an entry.....	69
Deleting an entry.....	69
Deleting the contents of the SIM card.....	69
Deleting the phonebook.....	64, 88
Editing an entry.....	69
Sending a vCard.....	56, 70
Setting automatic transfer.....	64, 88
Setting sorting.....	63, 87
Setting the storage location.....	63, 87
Settings.....	63
Transferring.....	64, 88
Transferring the phonebook entries manually.....	64
Picture format.....	29
Picture settings for TV mode.....	28
PIN.....	65
Pin Unblocking Key (PUK).....	66
Playlists (iPod).....	38
Points of interest.....	135
Searching by category.....	135
Searching by name.....	136
Searching by telephone number.....	136
Searching in the map view.....	136
Port	
USB.....	37
Previous calls.....	56, 70
Previous destinations (navigation).....	129
PTY filter.....	22
PUK.....	66

## R

Radio.....	19
PTY filter.....	22
RDS.....	22
Setting the mode.....	19
Storing stations on station buttons.....	20
Traffic programme.....	21
Tuning to stations.....	19
RDS.....	22
Switching radio text on/off.....	22
Switching RDS on/off.....	22
Switching regionalisation on or off.....	22
Rear view camera.....	104
Parking with the display.....	106
Picture settings.....	107
Switching on grid lines.....	106
Switching the display on/off.....	105
Received calls.....	57, 71
Recording (Sport display)	
Continuing.....	116
Deleting.....	117
Evaluating.....	117
Renaming.....	117
Starting.....	115
Stopping.....	116
Recording a trip section (trace).....	145
Recording laps (Sport display).....	115
Redialling.....	55, 68, 84
Reference lap (Sport display)	
Defining.....	118
Deleting.....	119
Renaming.....	118
Resetting.....	118
Regional code.....	32
Rejecting a call.....	54, 67
Reloading data.....	147
Reloading navigation data.....	147
Renaming	
Contact person (logbook).....	111
Driver (logbook).....	111
Recording (Sport display).....	117
Reference lap (Sport display).....	118
Trip destination (logbook).....	111
Trip purpose (logbook).....	111
Repeating (track).....	35
Repeating a track	
AUX BT.....	46
CD/DVD.....	35
iPod.....	39
USB.....	43

Resetting personal settings .....	17
Resetting settings .....	17
Resetting trip data .....	101
Restoring factory settings .....	17
Restoring vehicle handover settings .....	17
Right rotary knob .....	8
Ringtone type .....	60, 81
Ringtone volume .....	60, 81
Route	
Displaying sections .....	98
Route alternatives .....	128
<b>S</b>	
Safety notice (navigation) .....	127
Scanning (radio mode) .....	20
Searching for a track	
iPod .....	37
MP3 CD .....	36
USB .....	41
Searching for music	
MP3 CD .....	36
USB .....	41
Sections of the route .....	98
Selecting a chapter (video DVD mode) .....	34
Selecting a track	
CD/DVD .....	34
MP3 CD .....	34
Selecting display of the arrival time in the map view .....	153
Sending a destination from the personal destination memory .....	133
Sending own number .....	84
Setting	
3D map display .....	149
Adaptation of the central vents .....	124
Air flow strength .....	124
AudioPilot .....	13
Automatic air circulation .....	124
Automatic call answering .....	84
Balance .....	12
Bass .....	12
Brightness (rear view camera) .....	107
Brightness (TV) .....	28
Brightness of the display .....	15
Call forwarding .....	83
Cancelling a detour .....	137
Colour (rear view camera) .....	107
Colour (TV) .....	28
Colours for the display .....	15
Comfort options .....	123
Contents of the personal display .....	100
Contrast (rear view camera) .....	107
Contrast (TV) .....	28
Day design .....	15
Daytime running lights .....	121
Display .....	15
Display layout in the map view .....	151
Displaying the total route in the map display .....	150
DVD audio format .....	35
DVD audio groups .....	35
Dynamic route planning .....	138
Entry aid .....	124
Fade-out time .....	121
Fade-out time for the interior lights .....	122
Fader .....	12
Fast/short route .....	138
Folding in of the exterior mirrors .....	124
Headlight alignment (driving on left/right) .....	121
Keyboard layout .....	11
Language .....	16
Language for voice control .....	158
Layout of the input menu .....	11
Layout of the letters on the keyboard in the input menu .....	11
Light options .....	121
Locking of the doors .....	123
Loudness .....	12, 13
Lowering of the exterior mirror .....	123
Making a detour around a section .....	136
Mode (AUX BT) .....	45
Mode (AUX) .....	44
Mode (CD/DVD) .....	34
Mode (iPod) .....	37
Mode (radio) .....	19
Mode (TV) .....	24
Mode (USB) .....	41
Night design .....	15
Opening of the rear blind .....	123
Options for air conditioning .....	124
Orientation light .....	122
Preset memory .....	20
Rain sensor .....	122
Rear wiper .....	122
Reception country (TV) .....	28
Relocking .....	123
Ringtone type .....	81
Ringtone volume .....	81
SDV (speed-dependent volume) .....	12
Sorting criteria for the station list .....	23
Sorting of the station list (TV) .....	27
Sound conditioner .....	13
Station (radio) .....	19
Station (TV) .....	24
Surround .....	13, 14
Switching the touchscreen on/off .....	15
Treble .....	12
Units .....	15, 16
Unlocking of the doors .....	123
Use of the upper ventilation zone .....	124
Volume .....	6
Volume of the navigation announcement .....	127
Volume of the traffic programme announcements .....	21
Wiper options .....	122
Setting a block for a route section .....	136
Setting a detour .....	136
Setting a fast/quick route .....	138
Setting a perspective map .....	152
Setting a short route .....	138
Setting adaptation of the central vents .....	124
Setting AM mode .....	19
Setting AudioPilot .....	13
Setting automatic air circulation .....	124
Setting automatic transfer of the phonebook .....	88
Setting autozoom .....	150
Setting colours for the display .....	15
Setting comfort options .....	123
Setting consumption .....	16
Setting dynamic route planning (TMC) .....	138
Setting filtering of background noise .....	13
Setting FM mode .....	19
Setting folding in of the exterior mirrors .....	124
Setting light options .....	121
Setting locking of the doors .....	123
Setting picture parameters (rear view camera)	
Brightness .....	107
Colour .....	107
Contrast .....	107
Setting picture parameters (TV)	
Brightness .....	28
Colour .....	28
Contrast .....	28
Format .....	29
Setting relocating .....	123
Setting ringtones .....	81
Setting SDV (speed-dependent volume) .....	12
Setting sound conditioner .....	13
Setting surround .....	13, 14
Setting the air conditioning .....	124
Setting the air flow strength .....	124
Setting the audio source .....	6
Setting the balance .....	12
Setting the bass .....	12

Setting the brightness (TV mode) .....	28
Setting the colours for the map .....	153
Setting the day design .....	15
Setting the daytime running lights .....	121
Setting the display layout .....	151
Setting the display of 3D points of interest .....	152
Setting the display of additional data (Sport display) .....	119
Setting the display of satellite images .....	152
Setting the display of speed limits .....	152
Setting the fade-out time .....	121
Setting the fade-out time for the interior lights .....	122
Setting the fader .....	12
Setting the headlight alignment (driving on left/right) .....	121
Setting the junction zoom in the map view .....	152
Setting the keyboard layout .....	11
Setting the language .....	16
Setting the layout of the letters on the keyboard in the input menu .....	11
Setting the loudness .....	12, 13
Setting the mode (CD/DVD) .....	34
Setting the night design .....	15
Setting the orientation light .....	122
Setting the preset memory in radio mode .....	20
Setting the reception country for TV mode .....	28
Setting the standard trip for the logbook .....	108
Setting the temperature display .....	16
Setting the treble .....	12
Setting the units .....	15, 16
Setting the volume .....	6
Setting the volume for a voice control system announcement .....	158
Setting transfer of your own number .....	84
Setting TV mode .....	19
Setting unlocking of the doors .....	123
Setting use of the upper ventilation zone .....	124
Setting wiper options .....	122
Settings	
Bluetooth® (external Bluetooth® audio source) .....	46
Bluetooth® (logbook) .....	113
Bluetooth® (navigation) .....	133
Bluetooth® (Sport display) .....	120
Bluetooth® (telephone) .....	61, 85
Calls .....	83
Display .....	15
Extended memory .....	121
Messages and data .....	88
Phonebook .....	63, 87
Picture settings (rear view camera) .....	107
Picture settings (TV) .....	28
Radio mode .....	22
SIM card .....	82
Telephone (PCM telephone) .....	80
Telephone settings .....	60
Shuffle function	
AUX BT .....	46
CD/DVD .....	35
iPod .....	39
USB .....	43
SIM card	
Deleting the contents .....	69
Inserting the card .....	65
SIM settings .....	82
SIM slot .....	8
Skipping a track (CD/DVD, USB or iPod mode) .....	7, 8
Skipping tracks	
AUX BT .....	46
CD/DVD .....	35
iPod .....	39
USB .....	43
Slot for the SIM card .....	8
SMS .....	74
Accepting vCards .....	78
Calling telephone numbers .....	79
Creating a template .....	80
Creating and sending a new text message .....	76
Creating using a text template .....	77
Creating with attached reply .....	75
Creating with new text .....	75, 76
Deleting .....	78
Deleting vCards .....	79
Discarding vCards .....	79
Displaying the complete text .....	80
Editing and sending the text of the last message .....	77
Editing vCards .....	78
Forwarding .....	77
Numbers in text messages .....	79
Reading .....	75
Reading a vCard .....	78
Replying .....	75
Replying using a text template .....	76
Replying with Yes or No .....	76
Storing coordinates .....	80
Storing telephone numbers .....	79
Using coordinates for route guidance .....	80
SMS service centre .....	88
SMS settings .....	88
SMS signal tone .....	88
Sound settings	
Setting AudioPilot .....	13
Setting SDV .....	12
Setting sound conditioner .....	13
Setting surround .....	13, 14
Setting the balance .....	12
Setting the bass .....	12
Setting the fader .....	12
Setting the loudness .....	12, 13
Setting the treble .....	12
Sport Chrono package .....	115
Sport display .....	115
Continuing recording .....	116
Defining the reference lap .....	118
Deleting a lap .....	118
Deleting a recording .....	117
Deleting the reference lap .....	119
Ending a lap .....	116
Evaluating a recording .....	117
Renaming a recording .....	117
Renaming the reference lap .....	118
Resetting the defined reference lap .....	118
Setting the display of additional data .....	119
Starting a new lap .....	116
Starting recording .....	115
Stopping recording .....	116
Storing a lap as the reference lap .....	118
Timing the interval .....	116
Transferring data .....	119
Stalk for direction indicators, high beam and headlight flasher .....	157
Starting a new lap (Sport display) .....	116
Starting a search (radio or TV mode) .....	7, 8
Starting route guidance .....	128
Starting/stopping scanning	
AUX BT .....	46
CD/DVD .....	35
USB .....	43
Station buttons .....	19, 20, 24
Station list .....	19, 20
PTY filter (programme type) .....	22
Setting sorting (TV) .....	27
Setting sorting criteria .....	23
Station search .....	19
Status of the call diversion .....	83
Stopovers .....	139
Deleting .....	140
Entering .....	139
Reorganising .....	141
Storing .....	141
Via destinations .....	140

Stopping route guidance.....	128
Storing	
Coordinates (vehicle position) .....	80
Destination (off-road navigation) .....	142
Destination from the list of previous destinations	
in the personal destination memory .....	130
Key assignment in the logbook .....	111
Lap as reference lap .....	118
Phonebook entry .....	69
Position .....	142
Refuelling stop (logbook).....	110
Station (radio).....	20
Station (TV).....	25
Telephone number .....	70, 71
Telephone numbers from a text message .....	79
Storing a destination.....	130, 142
Storing a lap as the reference lap (Sport display) .....	118
Storing a position (off-road navigation).....	142
Storing stations.....	20, 25
Choosing a station in the station list and storing it .....	20
Storing stations manually .....	21
Storing stations manually (TV).....	25
Storing via an automatic station search (radio).....	21
Storing via an automatic station search (TV).....	25
Storing TV stations .....	25
Supplementary services.....	74
Supported audio formats .....	32
Switching	
Switching to an external audio source .....	44
Switching to an external Bluetooth® audio source .....	45
Switching to radio mode .....	19
Switching between day/night.....	15, 153
Switching between main menus.....	9
Switching device on/off .....	5
Switching grid lines for the rear view camera on .....	106
Switching on/off.....	5
RDS .....	22
Switching the touchscreen on/off .....	15

## T

Telephone	
Accepting a call.....	53, 66
Automatic call answering .....	84
Bluetooth®.....	50
Call waiting .....	58, 73
Call waiting (swapping) and conference .....	59, 73
Calling a phonebook entry .....	56, 69
Changing the PIN .....	82
Conducting calls with the hands-free unit .....	53, 66
Dialling a number .....	54, 67
Direct dialling.....	55, 68
Displaying the IMEI.....	81
Displaying the phonebook .....	55, 69
Ending a call .....	54, 67
Entering the PIN .....	65
Entering the PUK .....	66
Establishing an additional call.....	58, 72
Holding a call .....	55, 68
Inserting the SIM card .....	65
List of previous calls .....	56, 70
List of received calls .....	57, 71
Making an emergency call .....	74
Muting the microphone .....	53, 66
Number of the SMS service centre .....	88
Redialling .....	55, 68
Rejecting a call.....	54, 67
Selecting a network .....	81
Setting call forwarding.....	83
Setting the call volume .....	60
Setting the microphone volume .....	60
Setting the redial function.....	84
Setting the ringtone type.....	60, 81
Setting the ringtone volume .....	60, 81
Setting transfer of your own number .....	84
Settings (PCM telephone).....	80
SMS settings .....	88
Supplementary services.....	74
Switching call waiting on/off .....	84
Switching on/off.....	80
Switching the PIN prompt on and off .....	82
Switching the SMS signal tone on/off.....	88
Text messages (SMS).....	74
Touch tone dialling (DTMF tones).....	54, 67
Using a stored PIN.....	82
Telephone conference .....	59, 73
Text message (SMS).....	74
Accepting vCards .....	78
Calling telephone numbers .....	79
Creating a template .....	80
Creating and sending a new text message .....	76
Creating using a text template .....	77
Creating with attached reply .....	75
Creating with new text .....	75, 76
Deleting .....	78
Deleting vCards.....	79
Discarding vCards.....	79
Displaying the complete text.....	80
Editing and sending the text of the last message .....	77
Editing vCards.....	78
Forwarding .....	77
Numbers in text messages .....	79
Reading .....	75
Reading a vCard .....	78
Replying .....	75
Replying using a text template.....	76
Replying with Yes or No .....	76
Storing coordinates.....	80
Storing telephone numbers.....	79
Using coordinates for route guidance .....	80
Timing the interval (Sport display) .....	116
TMC messages .....	96
Touch tone dialling.....	54, 67
TP (traffic programme) .....	21
Tracing .....	145, 146
Tracing a route.....	146
Track list	
iPod .....	38
USB .....	42
Traffic Message Channel .....	96
Traffic messages (TP).....	21
Traffic programme	
Activating traffic programme announcements .....	21
Setting the volume of the announcements .....	21
Transferring data (logbook) .....	112
Transferring data (Sport display).....	119
Trip data .....	100
Tuner .....	19
Tuning to stations	
Tuning to stations by entering the frequency manually .....	20
Tuning to stations using the station buttons .....	19
Tuning to stations using the station buttons (TV) .....	24
Tuning to stations using the station list .....	19
Tuning to stations via a station search .....	19
Tuning to stations via a station search with scanning .....	20
Tuning to stations (TV)	
Displaying the TV picture.....	24

Tuning to TV stations .....	24
TV	
Calling up the main menu .....	24
Electronic Programme Guide (EPG) .....	27
Setting picture parameters .....	28
Setting sorting of the station list .....	27
Setting the reception country .....	28
Setting TV mode .....	24
Storing TV stations .....	25
Tuning to TV stations .....	24
Video text .....	26
Twin SIM cards .....	65

## U

Undoing a menu selection .....	8
USB .....	40
Fast forward/reverse .....	43
Repeating a track .....	43
Searching for a track .....	41
Searching for music .....	41
Shuffle function .....	43
Skipping to the next track .....	43
Starting/stopping scanning .....	43
Switching to USB mode .....	41
Track list .....	42
USB interface of the PCM .....	40
Using geographical coordinates from an SMS for route guidance .....	80

## V

vCard	
Accepting .....	78
Discarding (deleting) .....	79
Editing .....	78
Sending .....	56, 70
Vehicle functions	
Adaptation of the central vents .....	124
Air flow strength .....	124
Automatic air circulation .....	124
Comfort options .....	123
Daytime running lights .....	121
Entry aid .....	124
Fade-out time .....	121
Fade-out time for the interior lights .....	122
Folding in of the exterior mirrors .....	124
Headlight alignment (driving on left/right) .....	121
Light options .....	121
Locking of the doors .....	123
Lowering the exterior mirror .....	123

Opening the rear blind .....	123
Options for air conditioning .....	124
Orientation light .....	122
Rain sensor .....	122
Rear wiper .....	122
Relocking .....	123
Unlocking of the doors .....	123
Use of the upper ventilation zone .....	124
Wiper options .....	122
Video text .....	26
Calling up video text .....	26
Placing video text over the TV picture .....	26
Selecting a video text page .....	26
Voice control .....	155
Activating .....	157
Commands .....	156
Deactivating .....	157
Emergency cases .....	166
Hands-free microphone .....	155
Operating example for CD/DVD mode .....	164
Operating example for navigation mode .....	169
Operating example for radio mode .....	161
Operating example for telephone mode .....	166
Operating lists .....	160
Performing voice adaptation .....	159
Setting quick dialogue .....	159
Setting repetition of commands .....	158
Setting the display of hints .....	159
Setting the language .....	158
Setting the volume of the announcement .....	158
Speech intelligibility .....	155
Symbols .....	157
Using the help function .....	159
Voice entries .....	157
Voice control commands	
Global commands .....	156
Local commands .....	156
Volume of the navigation announcement .....	127

## W

WAV .....	32
WMA .....	32

# Technical data

## Radio frequency ranges

VHF (FM): 87.5 - 108 MHz  
(manual tuning in 100 KHz increments)

MW (AM): 531 - 1602 KHz  
(manual tuning in 1 KHz increments)

## Tuning steps used during automatic station search

VHF (FM) 100 KHz

MW (AM) 9 kHz

## Regional codes for video DVDs

- Code 1: USA, Canada and US territories
- Code 2: Europe, Greenland, South Africa, Egypt and Middle East, Japan
- Code 3: Southeast Asia, South Korea, Hong Kong, Indonesia, Philippines, Taiwan
- Code 4: Australia, New Zealand, Mexico, Central America, South America
- Code 5: Russia and other countries of former USSR, Eastern Europe  
India, Africa
- Code 6: People's Republic of China
- Code 7: Not currently assigned
- Code 8: International territory such as cruise liners and airplanes

## Affiliated countries for TV tuner country settings

**Africa: Egypt**  
Egypt

**Africa: Morocco**  
Morocco

**Africa: North, South East Africa**  
Algeria, Equatorial Guinea, Ethiopia, Eritrea, Gambia, Ghana, Cameroon, Canary Islands, Cape Verde, Kenya, Comoros, Liberia, Libya, Madeira, Malawi, Mauritania, Mauritius, Mayotte, Mozambique, Nepal, Nigeria, Sahara, Zambia, São Tomé and Príncipe, Seychelles, Sierra Leone, Zimbabwe, Somalia, Sudan, Swaziland, Tunisia, Uganda, other African countries, other Far Eastern countries, other overseas countries

**Africa: Southern Africa**  
Angola, Botswana, Lesotho, Namibia, South Africa, Tanzania,

**Africa: Central Africa, Madagascar**  
Benin, Burkina Faso, Burundi, Ivory Coast, Democratic Republic of Congo, Djibouti, Gabon, Guinea, Guinea-Bissau, Congo, Madagascar, Mali, Niger, Réunion, Rwanda, Senegal, Togo, Chad, Central African Republic

**America: Falkland Islands**  
Falkland Islands

**America: French overseas departments**  
French Guyana, Guadeloupe, Martinique, New Caledonia

**America: Caribbean**  
United States Virgin Islands, Antigua and Barbuda, Aruba, Bahamas, Barbados, British Virgin Islands, Curaçao (Netherlands Antilles), Dominica, Dominican Republic, Grenada, Haiti, Jamaica, Cayman Islands, Cuba, Netherlands Antilles, Puerto Rico, St. Lucia, St. Martin (Netherlands Antilles), St. Pierre and Miquelon, St. Vincent and the Grenadines, Trinidad and Tobago, Turks and Caicos Islands

**America: Central America**  
Belize, Costa Rica, El Salvador, Guatemala, Honduras, Mexico, Nicaragua, Panama, other Latin American countries

**America: North America**  
Bermuda, Canada, United States of America (USA), other American countries

**America: South America**  
Argentina, Bolivia, Brazil, Chile, Ecuador, Guyana, Columbia, Paraguay, Peru, Surinam, Uruguay, Venezuela

**Asia: Brunei**  
Brunei Darussalam

**Asia: China**  
China

**Asia: Hong Kong**  
Hong Kong

**Asia: India**  
India

**Asia: Japan**  
Japan

**Asia: Kuwait**  
Kuwait

**Asia: Malaysia**  
Malaysia

**Asia: Central Asia, Mongolia, Bhutan**  
Bhutan, Kazakhstan, Kyrgyzstan, Mongolia, Tajikistan, Turkmenistan, Uzbekistan

**Asia: Myanmar**  
Myanmar (Burma)

**Asia: Middle East, Afghanistan**  
Afghanistan, Gaza Strip, Iraq, Iran, Israel, Yemen, Jordan, Lebanon, Qatar, Syria, Cyprus, other Middle and Near Eastern countries

**Asia: North Korea**

Democratic People's Republic of Korea

**Asia: Oman**

Oman

**Asia: Philippines**

Philippines

**Asia: Saudi Arabia**

Saudi Arabia

**Asia: Singapore**

Singapore

**Asia: South Asia**

Bangladesh, Indonesia, Cambodia, Laos, Macau, Maldives, Pakistan, Sri Lanka, West Indies, other Asian countries

**Asia: South Korea**

Republic of Korea

**Asia: Taiwan**

Taiwan

**Asia: Thailand**

Thailand

**Asia: United Arab Emirates**

Abu Dhabi, Bahrain, Dubai, United Arab Emirates

**Asia: Vietnam**

Vietnam

**Australia**

Australia, Australia/Oceania, Tuvalu, Vanuatu

**Australia: New Zealand**

New Zealand, New Zealand/Oceania, Pitcairn Island, Solomon Islands

**Europe: England, Ireland**

British Indian Ocean Territory, Great Britain, Ireland

**Europe: Finland**

Finland

**Europe: France, Monaco**

France, Monaco

**Europe: Northern, Central, Southern, South Eastern Europe**

Albania, Andorra, Azores, Belgium, Bosnia and Herzegovina, Bulgaria, Ceuta/Melilla, Denmark, Germany, Faroe Islands, Gibraltar, Greece, Greenland, Iceland, Italy, Federal Republic of Yugoslavia, Croatia, Luxembourg, Madeira, Malta, Macedonia, Montenegro, Netherlands, Norway, Austria, Portugal, Romania, Sweden, Switzerland, Slovenia, Spain, St. Helena, Turkey, Vatican City, other Western Europe countries

**Europe: Eastern Europe**

Armenia, Azerbaijan, Estonia, Georgia, Latvia, Lithuania, Moldavia, rest of the former USSR, Russian Federation, Ukraine, Hungary, Belarus, other Eastern European countries, other Comecon countries

**Europe: Poland, Slovakia, Czech Republic**

Poland, Slovakia, Czech Republic

**Pacific**

Fiji, French Polynesia, Kiribati, Marshall Islands, Micronesia (Federated States), Nauru, Oceania, Papua New Guinea, Samoa, Tonga, Wallis and Futuna

- "Other countries" means countries in this region not explicitly mentioned in the list
- Spelling of country names subject to correction

## Dear Customer,

In conformance with current EC guidelines, any person may operate this unit. This unit conforms to the current valid European or harmonised national standards.

It is guaranteed that the unit conforms to the currently applicable specifications regarding electromagnetic compatibility. Interference with other electrical/electronic devices caused by the unit, or interference with this unit caused by other electrical/electronic devices, is largely prevented.

**Harman/Becker Automotive Systems** declares herewith that this device, **PCM 3.1**, conforms to the basic requirements of applicable EC regulations and especially to the basic requirements and other relevant regulations of the R&TTE directive 1999/5/EC.

Further information is available on our Internet site  
<http://www.HarmanBecker.com/Porsche>.

CE 0700

## List of countries with

### GSM and Bluetooth approval (extract)

Albania	Finland	Lithuania	Russia
Andorra	France	Luxembourg	Serbia
Austria	Georgia	Macedonia	Slovakia
Belgium	Germany	Malta	Slovenia
Bosnia Herzegovina	Greece	Moldova	Spain
Bulgaria	Guernsey	Monaco	Sweden
Canada	Hungary	Montenegro	Switzerland
China	Iceland	Netherlands	Turkey
Croatia	Ireland	Norway	United Kingdom
Cyprus	Isle of Man	Poland	USA
Czech Republic	Italy	Portugal	
Denmark	Jersey	Romania	
Estonia	Latvia	Reunion	

Further information is available on our Internet site <http://www.HarmanBecker.com/Porsche>.



## Bluetooth approval



QDID: B015165

### Information on the laser equipment

At the date of manufacture this laser product was classified as a class 1 laser product in compliance with the national/international standards **DIN EN 60825-1 : 2003-10** and **DHHS Rules 21 CFR Subchapter J**. The laser beam in this class 1 laser product is so weak that it does not represent a hazard when used as intended. This product is designed in such a way that the laser beam is confined to the interior of the unit. However, this does not mean that the laser installed in the housing could not be classed as a laser product in a higher class without its housing. For this reason, you should never open the unit housing (nullification of warranty or goodwill).

#### Technical data of the laser installed in the unit:

Output of laser beam: 0.68mW (DVD) / 0.85mW (CD)

Wavelength of laser beam: 665nm (DVD) / 795 nm (CD)

The laser diode is not pulsed during operation.

