

2. Start the diagnostic application and select the required vehicle type.
3. Switch off ignition and replace control unit. → [430819 REMOVING AND INSTALLING CONTROL UNIT FOR PDCC](#)
4. Select the **PDCC** control unit in the **overview** .
5. Select the **Maintenance/repairs** tab.
6. **PDCC start-up** can now be selected. Press [F12] to continue.
7. Follow the instructions on **PIWIS Tester II 9818** and perform start-up process.
8. **Read out the fault memory** and erase it if necessary.
9. In the **Codings/adaptations** menu, select the **Automatic coding** function. Press [F12] to continue.
10. **Read out the fault memory** and erase it if necessary.
11. Switch off ignition and disconnect **PIWIS Tester II 9818** from the vehicle.

WM 430955 REPLACING RESERVOIR (PDCC) (EXCEPT CARRERA "EDITION", CARRERA CABRIOLET "EDITION", CARRERA 4 "EDITION", CARRERA 4 CABRIOLET "EDITION", GT3, GT3 RS)

TECHNICAL VALUES

Location	Description	Type	Basic value	Tolerance 1	Tolerance 2
Fastening screw for reservoir	Â	Tightening torque	10 Nm (7.5 ftlb.)	Â	Â

PRELIMINARY WORK

1. Remove the pump (pump/reservoir assembly). → [Removing Pump \(PDCC\)](#)

REPLACING RESERVOIR (PDCC)

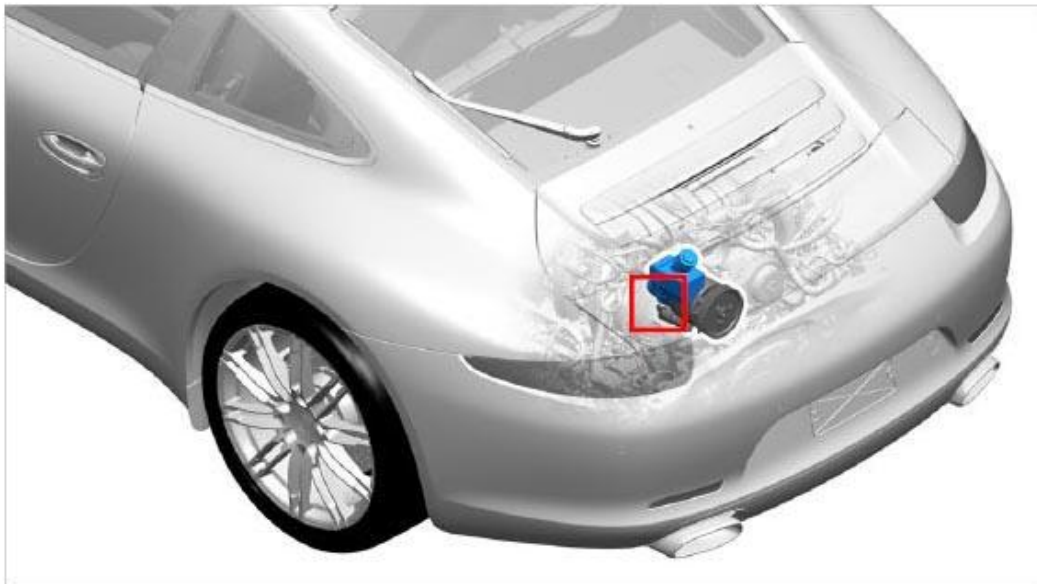

Fig. 61: Identifying Reservoir Position (PDCC)
 Courtesy of PORSCHE CARS NORTH AMERICA, INC.

WARNING: Caustic fluids

- Danger of chemical burns

→ Avoid contact with caustic fluid.

→ Wear personal protective gear.

→ Ensure that there is good ventilation.

→ If you do come into contact, wash off immediately with plenty of warm water and contact a doctor if necessary.

1. Remove the reservoir.

1.1. Set the pump down on a suitable absorbent cloth. Use a drip pan if there is one available.

1.2. Unscrew fastening screws -1- .

1.3. Pull the reservoir -2- off the pump -3- (-arrow-) and soak up (catch) the remaining fluid using a lint-free cloth.

1.4. Check the O-ring -4- on the pump and replace it if necessary.

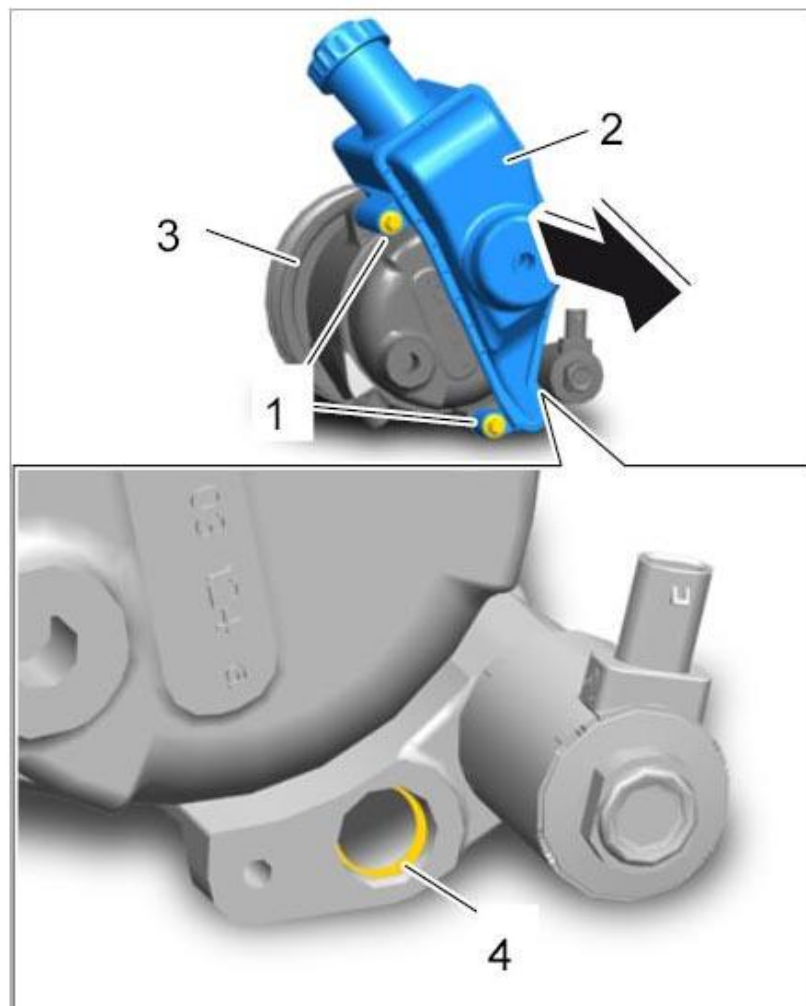

Fig. 62: Removing Reservoir

Courtesy of PORSCHE CARS NORTH AMERICA, INC.

2. Install new reservoir.

2.1. Press the new reservoir -2- into the pump -3- (-arrow-) and secure with the fastening screws -1- . → **Tightening torque: 10 Nm (7.5 ftlb.)**

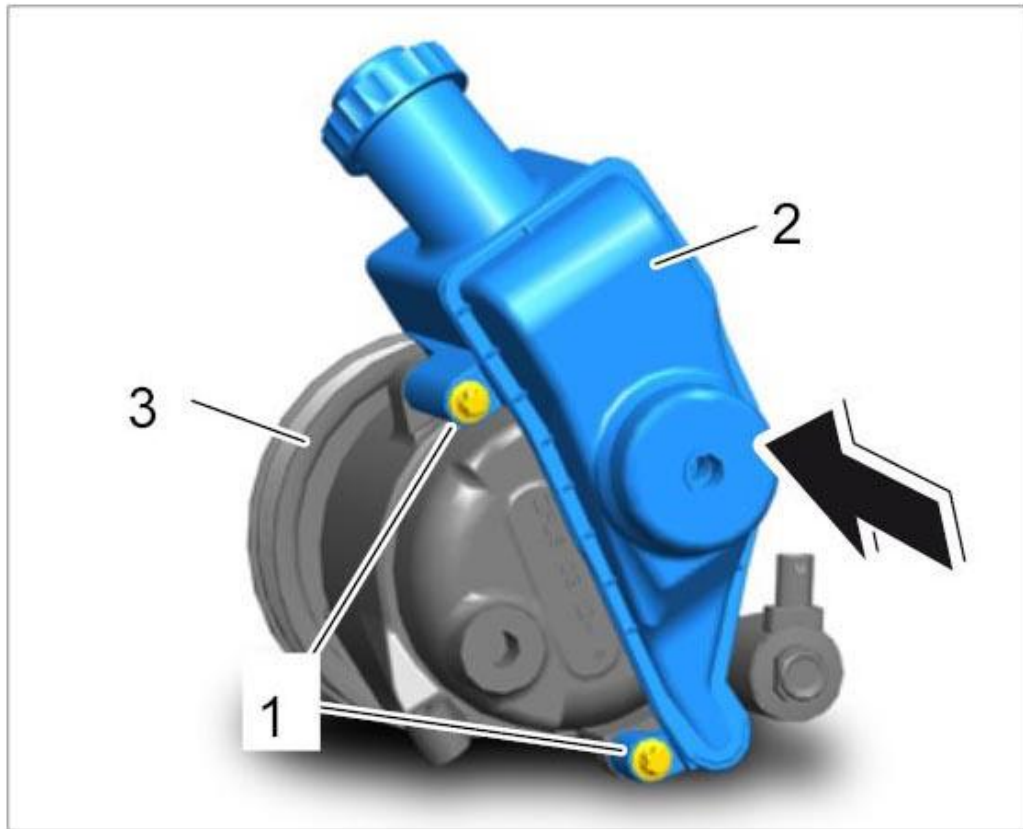

Fig. 63: Installing Reservoir
 Courtesy of PORSCHE CARS NORTH AMERICA, INC.

SUBSEQUENT WORK

1. Install the pump (pump/reservoir assembly). → [Installing Pump \(PDCC\)](#)

WM 431619 REMOVING AND INSTALLING PASM CONTROL UNIT (EXCEPT CARRERA "EDITION", CARR. CABRIO, CARR. S CABRIO, CARRERA GTS CABRIO, CARRERA CABRIOLET "EDITION", CARRERA 4 "EDITION", CARR. 4 CABRIO, CARR. 4S CABRIO, TURBO CABRIO, CARR. 4 GTS CABRIO, TURBO S CABRIO, CARRERA 4 CABRIOLET "EDITION")

TOOLS

Designation	Type	Number	Description	Â
PIWIS Tester II	Special tool	9818	Â	

PRELIMINARY WORK

1. Disconnect battery ground strap.
 → [2X00IN WORK INSTRUCTIONS AFTER DISCONNECTING THE BATTERY](#)
2. Remove rear cover.
 → [Removing rear cover](#)