

Carefully clean the transmission housing and ATF pan.

5. Clip coolant hoses -1- into the hose holder -2- .

Fig 5: Securing Coolant Hoses

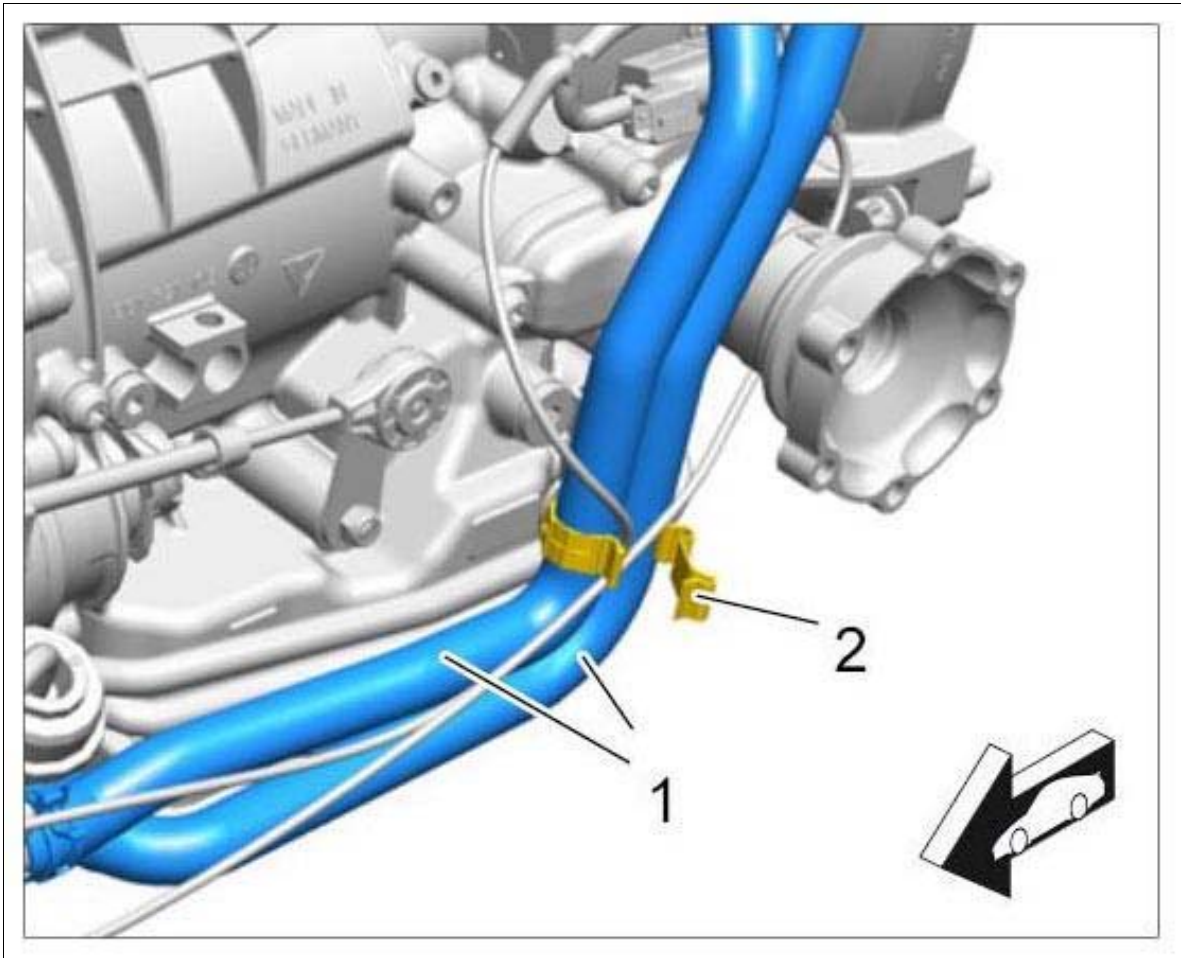

Courtesy of PORSCHE CARS NORTH AMERICA, INC.

6. Switch off engine.

### **WM 370235 CHECKING AND TOPPING UP ATF (CLUTCH FLUID) (EXCEPT CARRERA "EDITION", CARRERA CABRIOLET "EDITION", CARRERA 4 "EDITION", CARRERA 4 CABRIOLET "EDITION") > SUBSEQUENT WORK**

1. Install underbody cover.

→ 519419 REMOVING AND INSTALLING REAR UNDERBODY COVER .

### **WM 370255 CHANGING ATF (CLUTCH FLUID) (EXCEPT CARRERA "EDITION", CARRERA CABRIOLET "EDITION", TURBO, TURBO S, CARRERA 4 "EDITION", TURBO CABRIO, TURBO S CABRIO, CARRERA 4 CABRIOLET "EDITION", GT3) > TOOLS**

Designation	Type	Number	Description
-------------	------	--------	-------------

**WM 370255 CHANGING ATF (CLUTCH FLUID) (EXCEPT CARRERA "EDITION", CARRERA CABRIOLET "EDITION", TURBO, TURBO S, CARRERA 4 "EDITION", TURBO CABRIO, TURBO S CABRIO, CARRERA 4 CABRIOLET "EDITION", GT3) > TECHNICAL VALUES**

Location	Description	Type	Basic value	Tolerance 1	Tolerance 2
Drain plug for ATF pan	Replace drain plug	Tightening torque	15 Nm (11 ftlb.)	+3 Nm (+2 ftlb.)	

**WM 370255 CHANGING ATF (CLUTCH FLUID) (EXCEPT CARRERA "EDITION", CARRERA CABRIOLET "EDITION", TURBO, TURBO S, CARRERA 4 "EDITION", TURBO CABRIO, TURBO S CABRIO, CARRERA 4 CABRIOLET "EDITION", GT3) > INFORMATION**

**Information**

If a vehicle with Porsche Doppelkupplung (PDK) is not moved for more than 5 years, the ATF must be changed irrespective of the mileage driven since the last ATF change.

Fig 1: Overview Of ATF (Clutch Fluid)

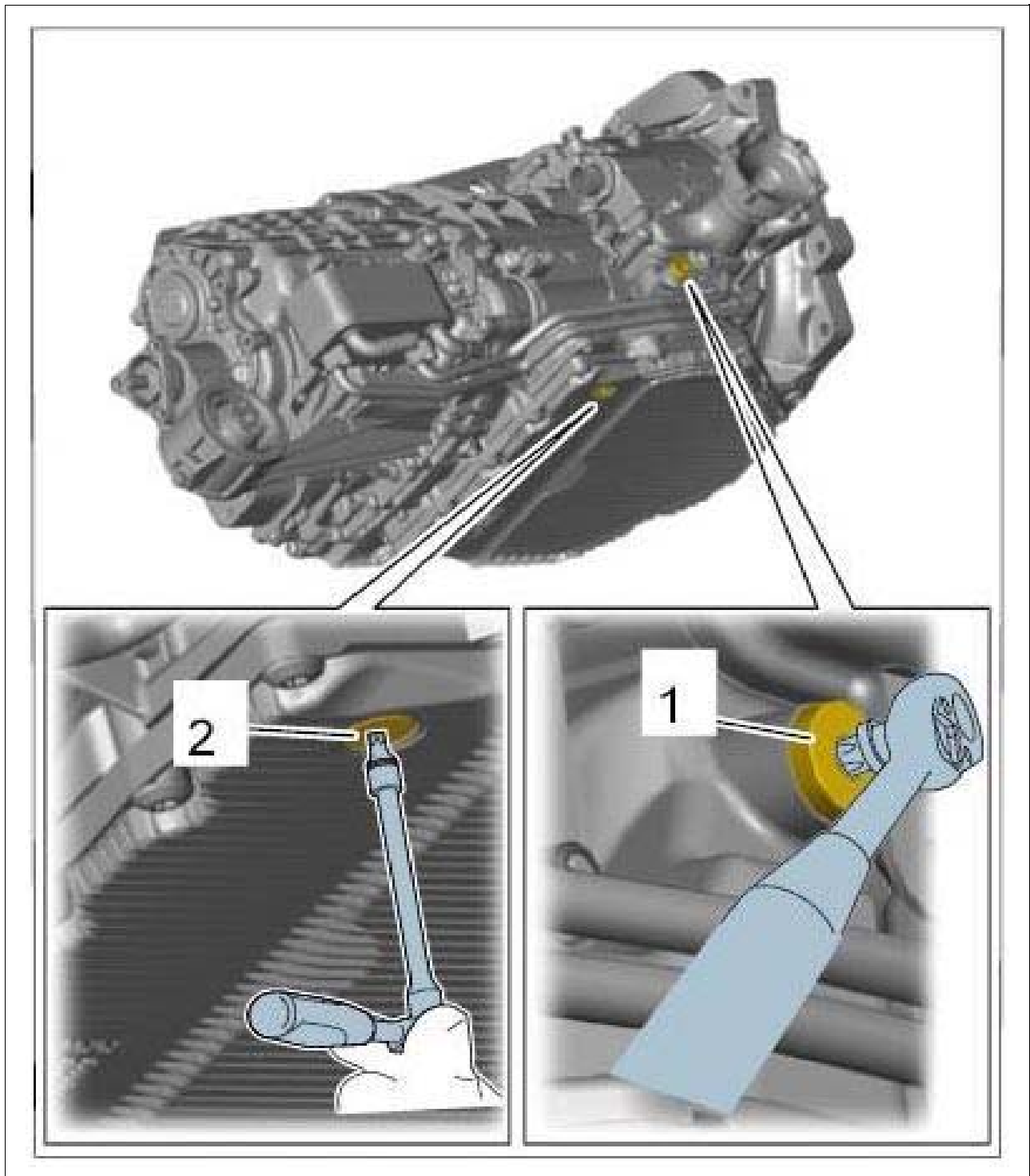

Courtesy of PORSCHE CARS NORTH AMERICA, INC.

1. Filler screw
2. Drain plug

**WM 370255 CHANGING ATF (CLUTCH FLUID) (EXCEPT CARRERA "EDITION",  
CARRERA CABRIOLET "EDITION", TURBO, TURBO S, CARRERA 4 "EDITION",**

## TURBO CABRIO, TURBO S CABRIO, CARRERA 4 CABRIOLET "EDITION", GT3) > PRELIMINARY WORK

1. Jack and raise the vehicle at the prescribed jacking points.

→ WM 4X00IN LIFTING THE VEHICLE

2. Remove rear underbody cover.

→ 519419 REMOVING AND INSTALLING REAR UNDERBODY COVER .

3. Place collection pan under the transmission.

## WM 370255 CHANGING ATF (CLUTCH FLUID) (EXCEPT CARRERA "EDITION", CARRERA CABRIOLET "EDITION", TURBO, TURBO S, CARRERA 4 "EDITION", TURBO CABRIO, TURBO S CABRIO, CARRERA 4 CABRIOLET "EDITION", GT3) > DRAINING ATF (CLUTCH FLUID)

 **WARNING: Hot fluid**

- *Danger of scalding*

→ Let the fluid cool down.

→ Wear personal protective gear.

1. Drain ATF.

1. 1.1. Unscrew ATF drain plug -1- and drain ATF.

2. 1.2. Screw in and tighten new drain plug -1- .

**Tightening torque 15 Nm (11 ftlb.) +3 Nm (+2 ftlb.)**

Fig 1: Identifying Drain Plug

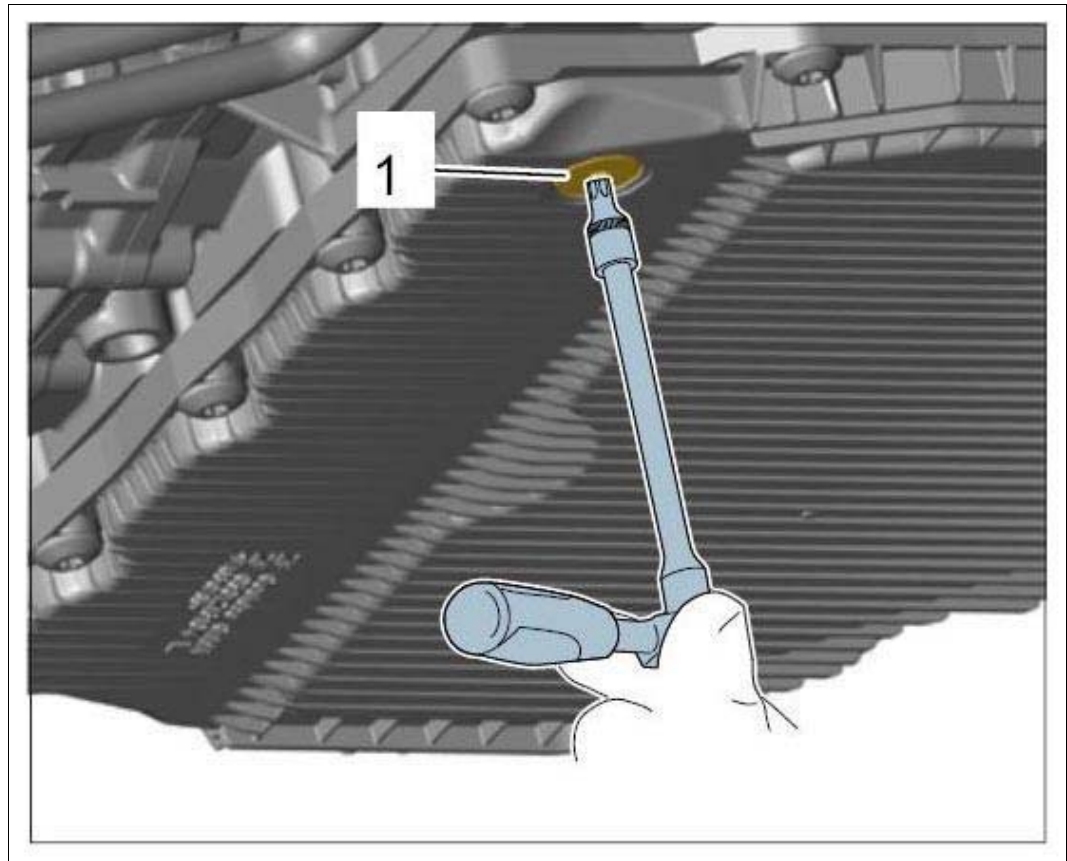

Courtesy of PORSCHE CARS NORTH AMERICA, INC.

**WM 370255 CHANGING ATF (CLUTCH FLUID) (EXCEPT CARRERA "EDITION", CARRERA CABRIOLET "EDITION", TURBO, TURBO S, CARRERA 4 "EDITION", TURBO CABRIO, TURBO S CABRIO, CARRERA 4 CABRIOLET "EDITION", GT3) > ADDING ATF (CLUTCH FLUID)**

**Information**

ATF specifications for Porsche Doppelkupplung (PDK):

- Storage: Store in a dry place, away from direct sunlight, at a temperature not less than -40 °C and not higher than +50 °C
- Storage time: 5 years from fill date on container
- Before using oil: Shake the container well for at least 10 seconds.

**Information**

Only use oil approved by Porsche in the Porsche Doppelkupplung (PDK) .

1. Fill in ATF.

1. 1.1. Unclip coolant hoses **-1-** from the hose holder **-2-** .

Fig 1: Loosening Coolant Hoses

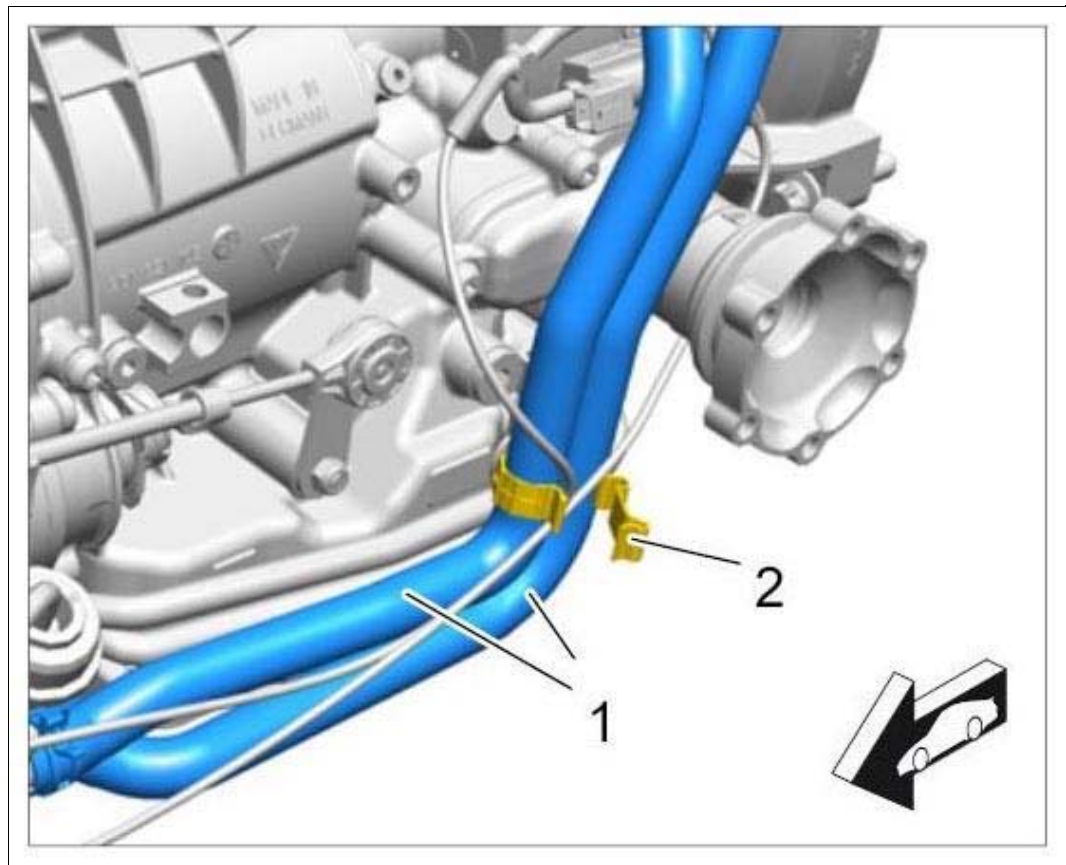

Courtesy of PORSCHE CARS NORTH AMERICA, INC.

### Information

Affix adhesive tape -1- to the area between the transmission housing and ATF pan to prevent dirt from getting into the oil pan.

Fig 2: Identifying Adhesive Tape On Transmission

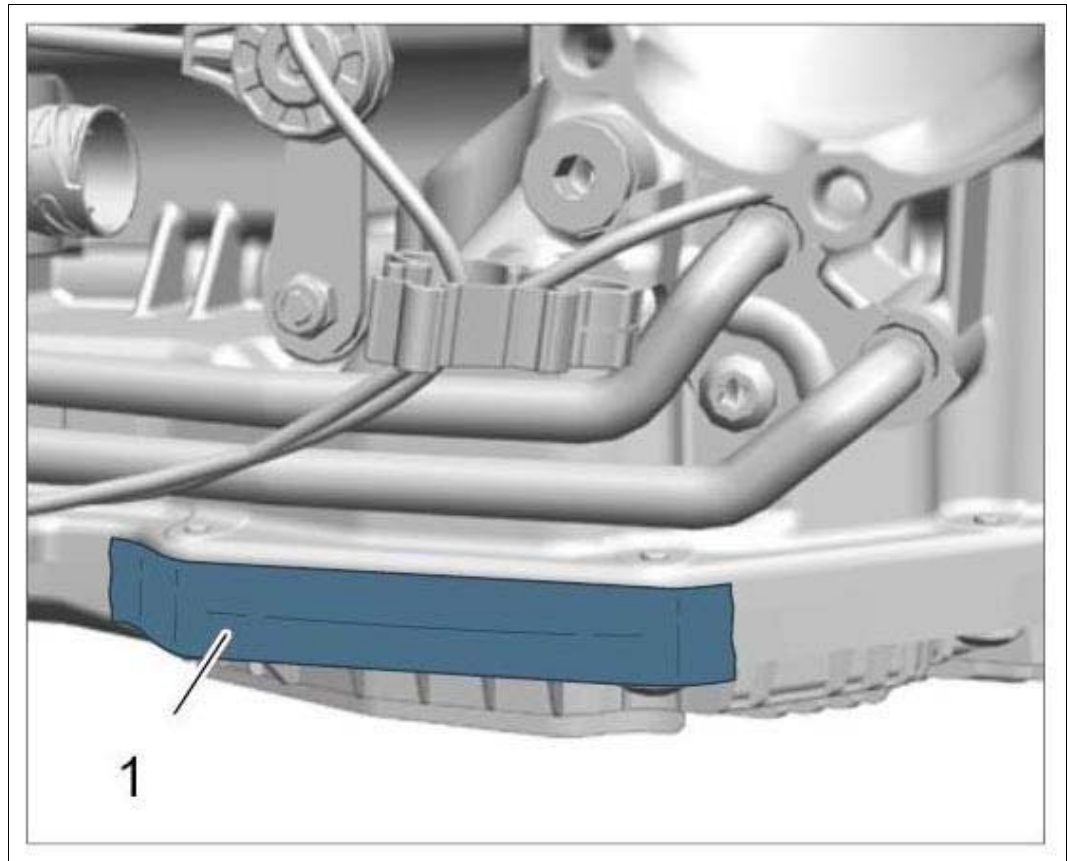

Courtesy of PORSCHE CARS NORTH AMERICA, INC.

2. 1.2. Unscrew filler screw -1- .

Fig 3: Tightening Oil Filler Screw

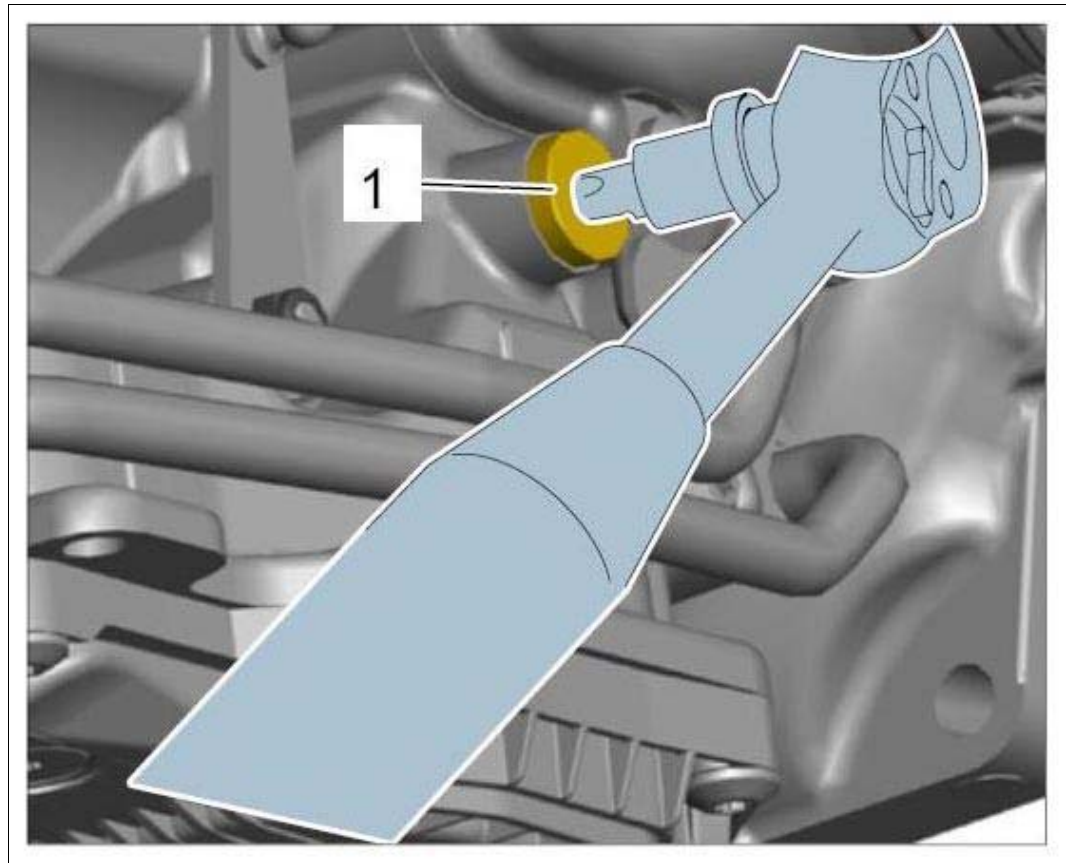

Courtesy of PORSCHE CARS NORTH AMERICA, INC.

3. 1.3. Fill in ATF at the filler bore using **manual metering pumps, Porsche set WE 1372** until ATF emerges.

4. 1.4. Tighten filler screw slightly.

2. Get the Porsche Doppelkupplung (PDK) ready and check ATF level.

→ 370235 CHECKING AND TOPPING UP ATF (CLUTCH FLUID) .

**WM 370255 CHANGING ATF (CLUTCH FLUID) (EXCEPT CARRERA "EDITION", CARRERA CABRIOLET "EDITION", TURBO, TURBO S, CARRERA 4 "EDITION", TURBO CABRIO, TURBO S CABRIO, CARRERA 4 CABRIOLET "EDITION", GT3) > SUBSEQUENT WORK**

1. Install rear underbody cover.

→ 519419 REMOVING AND INSTALLING REAR UNDERBODY COVER .

2. Lower the vehicle.

**WM 370419 REMOVING AND INSTALLING SELECTOR KNOB (EXCEPT CARRERA "EDITION", CARRERA CABRIOLET "EDITION", CARRERA 4 "EDITION", CARRERA 4 CABRIOLET "EDITION") > REMOVAL > REMOVING SELECTOR KNOB**