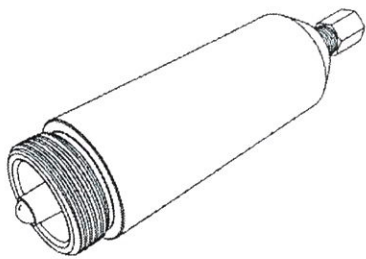
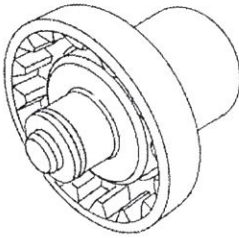

## WM 440519 Removing and installing wheel with central bolt

### Tools

Designation	Type	Number	Description	
wheel fitting trolley	Workshop equipment	WE 1300		 VAS 6266A.gif
assembly aid	Special tool	9794		<div style="border: 1px solid black; padding: 5px;"> <p>44</p>  <p>9794 000 721 979 40</p> </div>
socket wrench	Special tool	9796		<div style="border: 1px solid black; padding: 5px;"> <p>44</p>  <p>9796 000 721 979 60</p> </div>

### Technical values

Location	Description	Type	Basic value	Tolerance 1	Tolerance 2
Wheel to wheel hub/central bolt	All contact surfaces of the wheel, wheel hub and brake disc as well as the trapezoidal thread in the wheel hub must be free of abrasion, sand, dust or chips. Apply some aluminium paste (Optimoly TA) on the trapezoidal thread in the wheel hub if necessary. Grease the conical surface of the central bolt with a very light coating of aluminium paste before fitting each wheel. For advanced grease specifications (which are only necessary under certain conditions), refer to the description 440519 Removing and installing wheel with central bolt.	Step 1	600 Nm (444 ftlb.)		
Wheel to wheel hub/central bolt	All contact surfaces of the wheel, wheel hub and brake disc as well as the trapezoidal thread in the wheel hub must be free of abrasion, sand, dust or chips. Apply some aluminium paste (Optimoly TA) on the trapezoidal thread in the wheel hub if necessary. Grease the conical surface of the central bolt with a very light coating of aluminium paste before fitting each wheel. For advanced grease specifications (which are only necessary under certain conditions), refer to the description 440519 Removing and installing wheel with central bolt.	Step 2	-90°		
Wheel to wheel hub/central bolt	All contact surfaces of the wheel, wheel hub and brake disc as well as the trapezoidal thread in the wheel hub must be free of abrasion, sand, dust or chips. Apply some aluminium paste (Optimoly TA) on the trapezoidal thread in the wheel hub if necessary. Grease the conical surface of the central bolt with a very light coating of aluminium paste before fitting each wheel. For advanced grease specifications (which are only necessary	Step 3	600 Nm (444 ftlb.)		

## Information on central bolt

### Information regarding tool - central bolts (loosening and tightening the wheel bolt)

Only use the permitted **socket wrench 9796 -1-** on the 911 with centre-lock wheel!  
**Never use** the 9451 socket wrench **-2-** from the Carrera GT.

**Reason:** The lockable wheel bolt (locking mechanism) will break off because there is no plunger for releasing the lockable wheel bolt.

This means that the wheel will not be secured. This state of affairs can no longer be recognised once the hub cap is fitted!

**To prevent any risk of confusion, ensure that a suitable sticker is attached to the special tool from the Carrera GT - socket wrench 9451!**

Order number for this sticker = 000.721.945.11

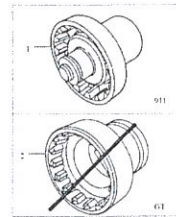

Socket wrench for central bolt

### Component overview - central bolt system

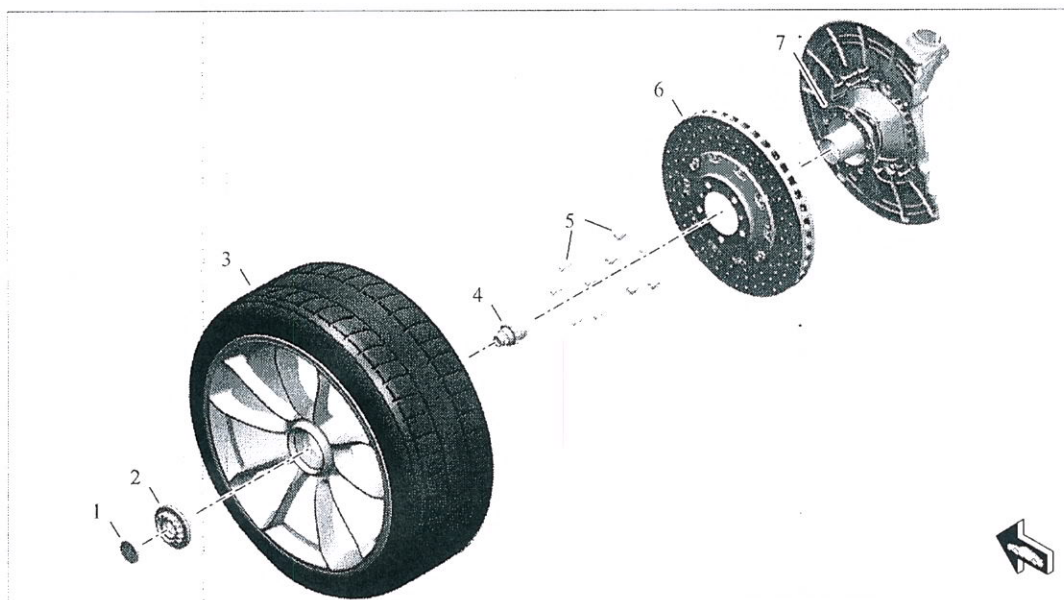

Component overview of central bolt system

- 1 - Hub cap
- 2 - Wheel bolt with cone ring (not available separately)
- 3 - Wheel
- 4 - Lockable wheel bolt/locking mechanism (not available separately)
- 5 - Wheel driver (only available in a set as spare part/5 ea. No. 5). Be aware of the difference between the 911 Turbo (991) and the 911 GT3 (991)!
- 6 - Brake disc (grey cast iron or PCCB)
- 7 - Wheel hub

The 911 Turbo (991) can be supplied with a central bolt as an optional extra.

A central bolt is provided as **standard** with the 911 GT3 (991). In terms of its design, the bolt is similar to that on the 911 Turbo (991). The colours of the wheels and the wheel bolts may be different. The design of the wheel drivers is also different.

The wheel bolt **-2-** is identical for all four wheels (right thread).

The lockable wheel bolt **-4-** is an assembly (only available as a whole) whose splines engage in the wheel hub **-7-** on one side and in the wheel bolt **-2-** on the other (**if activated**).

The lockable wheel bolt **-4-** can be pulled out of the wheel hub **-7-** once the wheel bolt **-2-** has been removed. **For safety reasons**, only remove the lockable wheel bolt **-4-** in order to check it and then re-insert it immediately in the wheel hub **-7-**.

Before fitting the wheel, check that the lockable wheel bolt **-4-** is functioning properly. Under no circumstances use the 997 lockable wheel bolt on the 991!

The contact surfaces of the wheel on the brake disc **-6-** must be clean and free of any grease or paint.

Wheel driver **-5-** (5 ea.) consisting of driving pin, sleeve and self-locking screw. Only one set (5 ea./for one wheel) is available as a spare part.

Five new wheel drivers **-5-** (1 set) must be fitted when replacing the brake disc. Does not apply to 911 GT3.

Tightening torque for self-locking screws:

M6x30 (911 Turbo) = 14 Nm / M8x32 (911 GT3) = 31 Nm

## Removing and installing wheel with central bolt

### Removing wheel with central bolt

#### NOTICE

#### Removing/fitting wheels

- **Damage to the rim and brake cover plate**
- **Undesired loosening of or damage to balancing weights**

→ Do not tilt wheel during removal/fitting from/on the wheel hub.

1. Raise the vehicle only at the jacking points provided. → *4X001N Lifting the vehicle*. Alternatively, raise the vehicle (handbrake on) until the wheel you want to work on is up off the ground.



#### Information

- *Release tool for removing the crested hub cap is available in the Parts Catalogue.*
  - *Alternatively, the release tool in luggage compartment can be used.*
2. Carefully lever the crested hub cap out using the special tool.  
**Insert its metal tab -1- into the opening groove on the central bolt and then swivel back the handle -arrow-.**

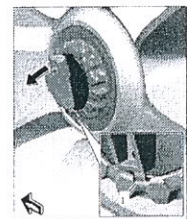

Removing crested hub cap



#### Information

- *When loosening the central bolt, make sure that the tool remains fully engaged and does not slide off even slightly (risk of damage to the lockable wheel bolt/locking mechanism).*

3. **Socket wrench 9796** (socket) must be positioned **and pushed on as far as it will go.**

This opens (unlocks) the lockable wheel bolt.

If the lockable wheel bolt (locking mechanism) is difficult to move in axial direction (becomes tilted in the wheel bolt tothing/socket cannot be fitted), loosen the locking mechanism using a suitable mandrel (press towards the wheel hub).

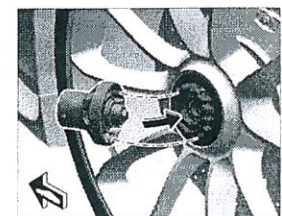

Positioning tool 9796

4.

Unscrew the wheel bolt you released using special tool **socket wrench 9796**. Get a second person to press the brake pedal to prevent the wheel from turning.

When loosening the central bolt, make sure that the tool remains fully engaged and does not slide off even slightly.

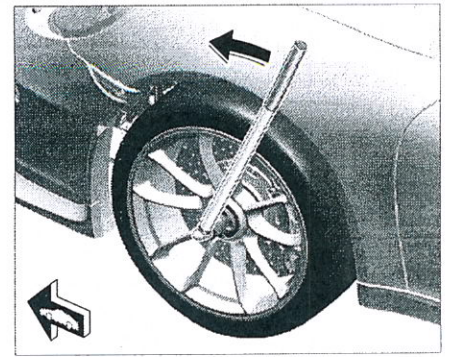

Opening central bolt (turning anti-clockwise)

5. Unscrew the central bolt and set it down in such a way that the conical area or trapezoidal thread cannot get dirty.

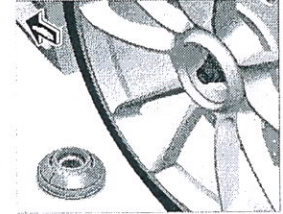

Unscrewing central bolt

6. On vehicles with PCCB brake discs, screw the **assembly aid 9794** (hub extension) -1- into the wheel hub before taking off the wheel. The lockable wheel bolt (locking mechanism) must first be removed.

This prevents damage to the brake disc when taking off the wheel.

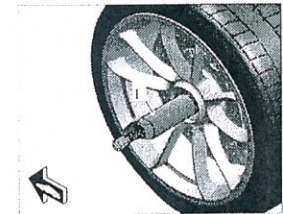

Hub extension (assembly aid)

7. Carefully take off the wheel.  
To do this, particularly for 911 Turbo models (991), use **wheel fitting trolley WE 1300** on the rear axle to prevent damage to the rim and brake cover plate!
8. On 911 Turbo models (991): Check rim and rear brake cover plate.
  - 8.1. Check inner part of rim for damage through the brake cover plate.
  - 8.2. Check that the balancing weights are fitted and secured correctly.
  - 8.3. Check brake cover plate for damage (kinks, dents, distortion, distance to brake disc).

### Installing wheel with central bolt

1. Carry out a visual inspection on the safety components listed below before fitting the wheel.
  - 1.1. Check the wheel bolt for damage.

There must be no scratches or cracks on the conical area, trapezoidal thread and inner toothing on the bolt.

Replace the wheel bolt if it is damaged or if you have any doubts.

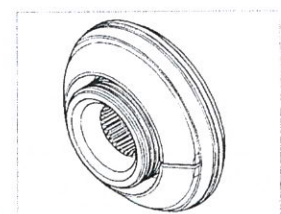

Wheel bolt (central bolt)

- 1.2. Check the condition and operation of the lockable wheel bolt (locking mechanism/one per wheel) and replace if necessary.

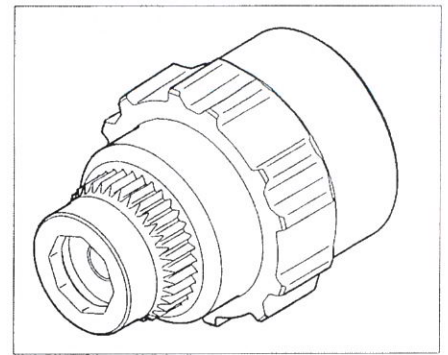

*Lockable wheel bolt (locking mechanism)*

- 1.2.1. Check that the toothed locking pin is not stiff. After pressing the pin into its cartridge, it must return automatically to its original position with force and without catching.
- 1.2.2. Check mechanical state and perform visual inspection (O-ring, inner and outer tothing).  
  
The lockable wheel bolt must not be repaired (O-ring can be replaced of course).
- 1.2.3. Replace the lockable wheel bolt assembly if it is damaged or if you have any doubts.
- 1.3. Before tightening the wheel bolt, check that the lockable wheel bolt (locking mechanism) is inserted.

**The lockable wheel bolt (locking mechanism) -1- must be in the wheel hub -2- .**

For safety reasons, only remove the lockable wheel bolt (locking mechanism) in order to check it and then re-insert it immediately in the wheel hub.

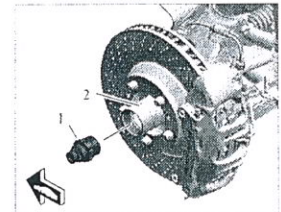

*Inserting the lockable wheel bolt in the wheel hub*

- 1.4. All contact surfaces of the wheel, wheel hub and brake disc as well as the trapezoidal thread in the wheel hub must be free of abrasion, sand, dust or chips.
- 1.5. **Apply some aluminium paste on the trapezoidal thread of the wheel hub if necessary.**
- 1.6. **Apply a thin coating of aluminium paste on the cylindrical part of the wheel hub.**
- 1.7. Only fit brake discs **with driving pins** that have been approved for centre-lock wheels.

2. Fit the wheel carefully. Make sure not to damage the brake disc when fitting the wheel.  
On vehicles with PCCB brake discs, use **assembly aid 9794** (hub extension) -1- !  
To do this, particularly for 911 Turbo models (991), use **wheel fitting trolley WE 1300** on the rear axle to prevent damage to the rim and brake cover plate!

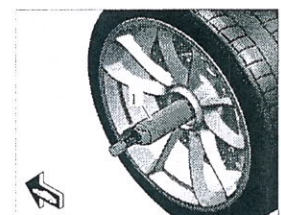

*Hub extension (assembly aid)*

When fitting the wheel, the vehicle must not be supported by the wheel to be secured.

3. Partly disassemble the central bolt if necessary before fitting the wheel and re-grease the sliding surfaces on the inside **with Optimoly TA (aluminium grease)**.



**Information**

Generally, there is no need to re-grease the inside of the bolt, except in the following situations:

- A very high or very low torque is required to loosen the central bolt (more than 700 Nm/518 ftlb. or less than 400 Nm/296 ftlb.).
- In the event of a jerking, fluctuating tightening torque.
- If you feel any stiffness or slip-slick effect when turning the cone ring -1- for the central bolt by hand (cone ring -1- turns back and forward). Apply a certain amount of pressure when checking (screwing the cone ring to the central bolt -arrows-).

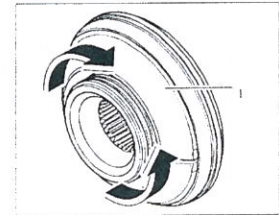

Cone ring on central bolt

- 3.1. Remove cone ring -1- from central bolt -3- .  
A circlip holds the cone ring -1- in the wheel bolt -3- .

To remove the cone ring -1- , detach it from the wheel bolt -3- by tapping sharply on a wooden base (threaded side facing down to the wood).

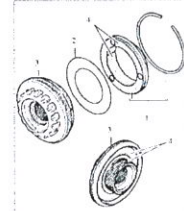

Disassembling and re-greasing central bolt

- 3.2. Re-grease surfaces of the disassembled central bolt (as described in the overview).

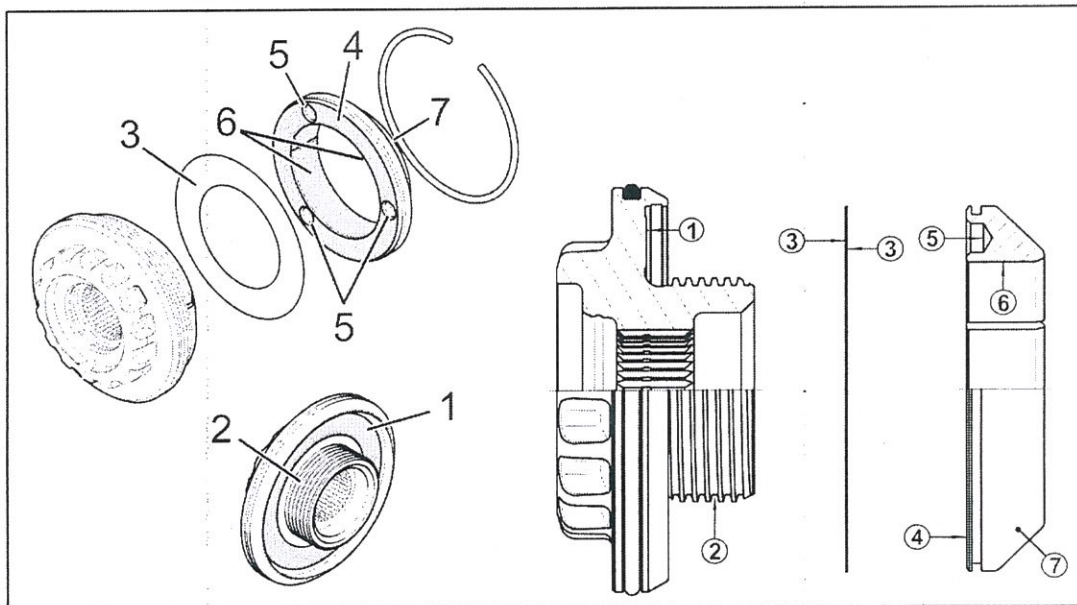

Overview - re-greasing central bolt

Surface	Designation	Grease with Optimoly TA (aluminium grease) Part No. 000.043.020.00
1	Circular area on central bolt -1-	Apply a <b>light</b> coating of grease (approx. 0.2 – 0.5 mm thick).
2	Trapezoidal thread on central bolt -2-	Apply a <b>generous</b> coating of grease (approx. 0.5 – 1.0 mm thick).
3	Washer -3-	Do <b>not</b> grease the washer (applies to both sides). The washer will be re-greased automatically on both sides during

		assembly and when the components are subsequently screwed together.
4	Circular area of cone ring -4-	Apply a <b>light</b> coating of grease (approx. 0.2 – 0.5 mm thick).
5	Reserve bores on cone ring -5-	Fill bores with grease so that they are 1/3 to 2/3 filled with grease.
6	Inner circular area on cone ring -6-	Apply a <b>light</b> coating of grease (approx. 0.2 – 0.5 mm thick).
7	Conical area on cone ring -7-	Apply a <b>light</b> coating of grease (approx. 0.2 – 0.5 mm thick).

3.3. Insert the cone ring into the wheel bolt in such a way that the circlip engages in the groove on the wheel bolt.

4. Grease the conical surface -1- of the central bolt with a **very light** coating of Optimoly TA (aluminium grease) before fitting each wheel. **Make sure no dirt sticks to it.**

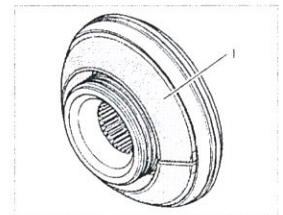

Greasing conical surface of wheel bolt



### Information

When fitting all wheels, the vehicle must never be supported by the wheel to be fitted. → *Lifting the vehicle*

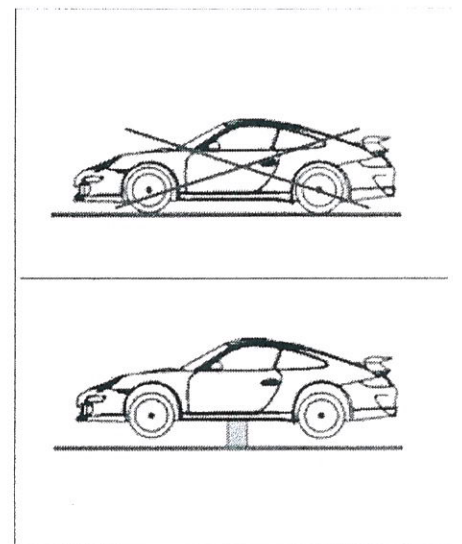

Lifting the vehicle

5. Insert the central bolt in the socket wrench 9796 (as far as it will go). Then position the central bolt vertically on the wheel hub and screw it on without tilting it.

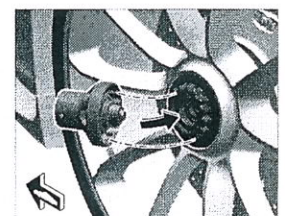

Positioning the socket wrench 9796

### Information



Get a second person to press the brake pedal to prevent the wheel from turning.

6. Use a suitable torque wrench (together with socket wrench 9796) to tighten the central bolt **using the three-step tightening procedure.**

Step 1 600 Nm (444 ftlb.)

Step 2 -90°

Step 3 600 Nm (444 ftlb.)

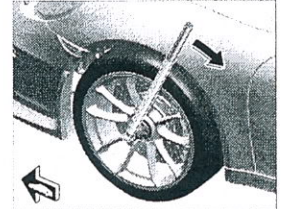

*Tightening the central bolt*

**⚠ WARNING**

**Unsecured central bolt**

- Risk of damage to components
- Danger of accidents

→ After fitting the wheel, make sure that the locking pin is engaged correctly in the central bolt.

7. Remove socket wrench 9796 and check that the locking pin **-1-** has already engaged automatically in the central bolt. The end of the locking pin is then flush with the inner tothing of the central bolt → *Wheel bolt secured* .

If the locking pin is still at the rear position → *Wheel bolt not secured* and has not yet engaged in the inner tothing of the central bolt, the central bolt is still not secured and must be secured **manually** to prevent it from becoming loose.

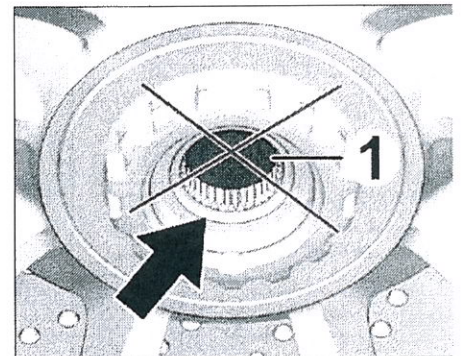

*Wheel bolt not secured*

When the central bolt is secured, the end of the locking pin **-1-** will be flush with the inner tothing of the central bolt.

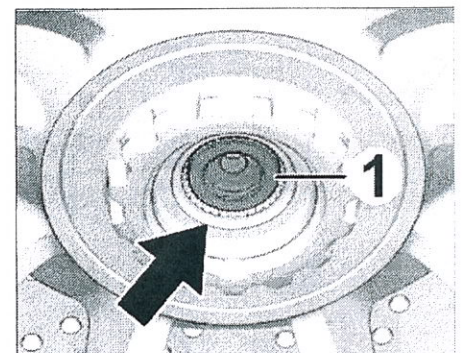

*Wheel bolt secured*

If required, turn the locking pin **-1-** to the left and right using an auxiliary tool or a 1/2-inch square extension **-direction arrows-** until it engages in the central bolt.

**This applies to both road and race track use.**



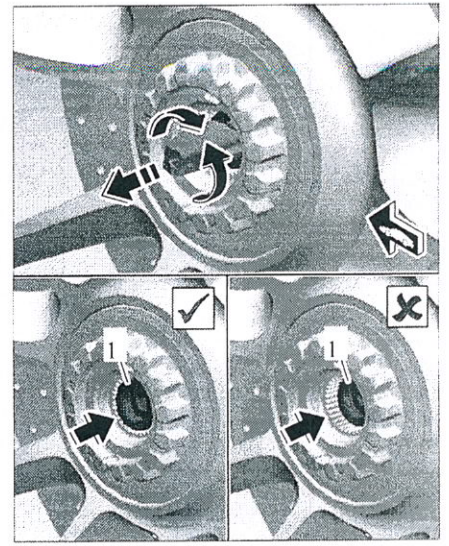

Securing the wheel bolt

8. Align the hub cap so that the **locating stud -1-** points into the **well -2-** of the central bolt.  
Now push the hub cap into its seat until it locks securely in place. Grease the rubber ring on the cap lightly beforehand if necessary.

**Now lower the vehicle.**

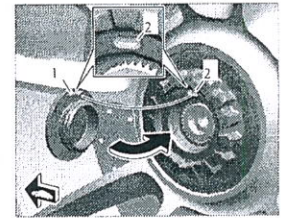

Fitting the hub cap

– **Tightening the central bolt in an emergency**

**If you do not have the correct torque wrench required to tighten the central bolt to the prescribed high tightening torque in a breakdown situation, the emergency tightening procedure must be performed.**

- 1. The central bolt must always be fitted using the original tool (stored in the luggage compartment).
- 2. Tighten the central bolt with a long lever **using a lot of force**. Then loosen the central bolt again slightly (by approx. 1/4 turn).

Use a torque wrench to tighten the central bolt to exactly 100 Nm (74 ftlb.).

Draw a line at the marking **^ 100 Nm** on the wheel.

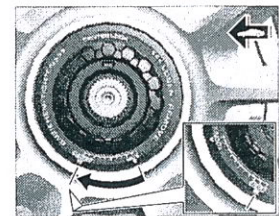

Emergency tightening procedure

- 3. Tighten the central bolt further with a long lever until **the square (Stop) marking** is aligned with the **line you made on the wheel**.  
This tightens the central bolt sufficiently to allow you to drive to the next qualified workshop.
- 4. **Tighten the central bolt immediately (at the next qualified workshop) to 600 Nm (444 ftlb.) using a suitable torque wrench and the three-step tightening procedure.**

991140, 991141, 991340, 991341, 991430, 991431, 991440, 991441, 991450, 991451, 991540, 991541, 991630, 991631, 991640, 991641, 991650, 991651, 991810, 991811, 991850, 991851, 991880, 991881

Model year as of 2014

C00, C02, C05, C06, C07, C08, C09, C10, C11, C12, C13, C14, C15, C16, C17, C18, C19, C20, C21, C22, C23, C24, C25, C26, C27, C28, C32, C33, C34, C35, C36, C37, C38, C39, C41, C45, C46, C96, C97, C98, C99

The present document was valid at the time of print. A later version may be available online

## WM 4X00IN Central wheel lock: Component assessment

### Central wheel lock: Component assessment

#### Information on component assessment

The following illustrations compare central wheel lock components as **they normally look on vehicles that have been driven** with components that **show signs of excessive wear**.

\* The following applies to the **wheel hub**: The wheel hub must always be replaced if the loosening torque of the relevant central bolt is less than 400 Nm (296 ftlb.) or if the driving pins can be turned by hand. It really doesn't matter how the wheel hub looks in this case. \*

**Prerequisite:** The central bolt was originally tightened to the prescribed tightening torque and the vehicle has since been driven.

The following also applies: If the vehicle that is being checked shows at least one sign of wear as shown, the affected component and other components, if necessary, must be replaced in accordance with the relevant instructions.

#### Wheel hub assessment

The wheel hub is assessed in three steps:

•  
•

##### 1. Check the wheel hub.

Examine the cylindrical surface of the wheel hub in the area in which the cone ring on the central bolt sits when the wheel is fitted → *Checking wheel hub* .

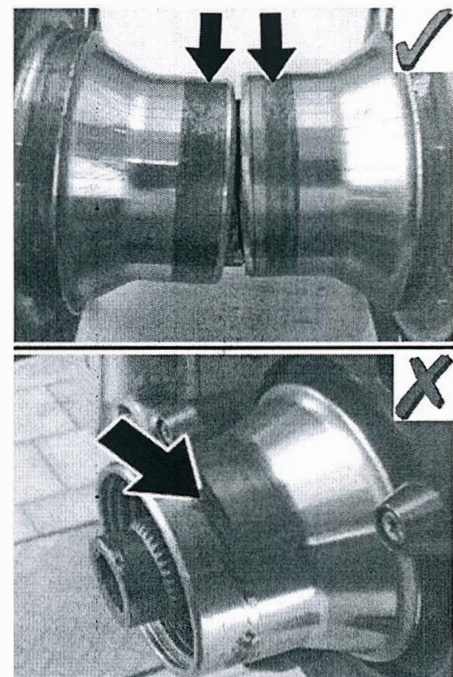

*Checking wheel hub*

**Wheel hub assessment**

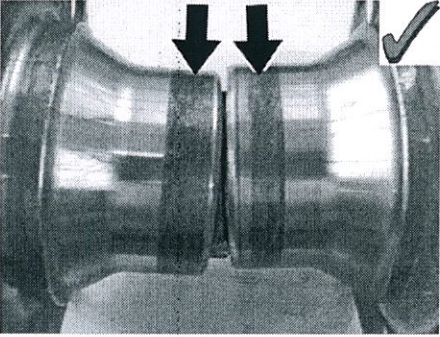
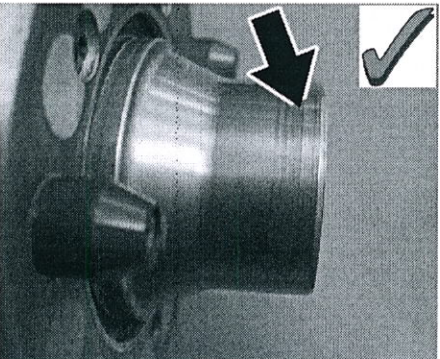
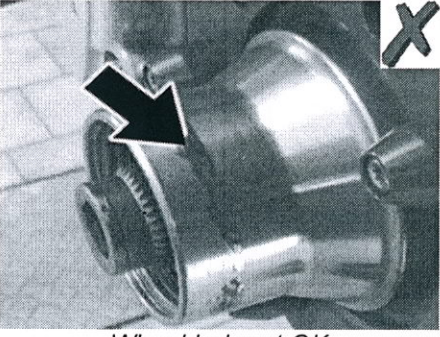
Looks normal for a vehicle that has been driven	Excessive signs of wear
<p><b>Wide contact pattern</b> → <i>Wheel hub OK</i></p> <ul style="list-style-type: none"> <li>• Contact pattern is at least <b>10 mm</b> wide on the cylindrical surface of the wheel hub <b>-arrows-</b> .</li> <li>• On vehicles with low mileage, the contact pattern may not be continuous, but must extend over an area that is at least <b>10 mm</b> wide → <i>Wheel hub OK (1)</i> .</li> <li>• The discolouration can vary from shiny metallic to dark grey.</li> </ul>	<p><b>Linear pattern</b> → <i>Wheel hub not OK</i></p> <ul style="list-style-type: none"> <li>• Narrow (linear) contact pattern that is uneven or only in spots on the cylindrical surface of the wheel hub <b>-arrow-</b> .</li> </ul>
<div style="text-align: center;">  <p><i>Wheel hub OK</i></p> </div> <ul style="list-style-type: none"> <li>• <b>Additional picture:</b></li> </ul> <div style="text-align: center;">  <p><i>Wheel hub OK (1)</i></p> </div>	<div style="text-align: center;">  <p><i>Wheel hub not OK</i></p> </div>
<b>Result/Action required</b>	
<p>⇒ The <b>wheel hub</b> does <b>not</b> have to be replaced.</p>	<p>⇒ The <b>wheel hub</b> must be replaced.</p>



**Information**

If it is not possible to determine clearly based on the contact pattern of the wheel hub whether the wheel hub looks normal for a vehicle that has been driven or whether it shows signs of wear, the **cone ring on the central bolt** and the **conical area on the wheel** must be examined in order to further assess the wheel hub (indirect check on wheel hub, see Steps 2 and 3).

2.

Check the wheel hub based on the appearance of the **cone ring on the central bolt** ( → *Checking cone ring on central bolt* ).

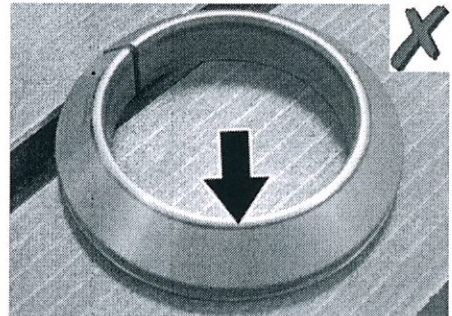
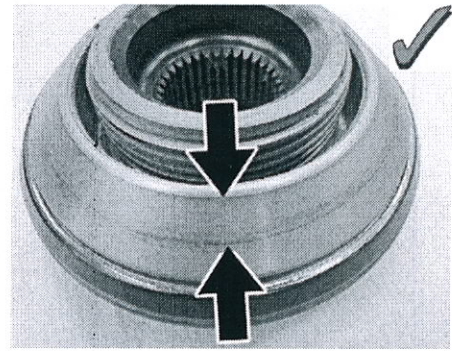

*Checking cone ring on central bolt*

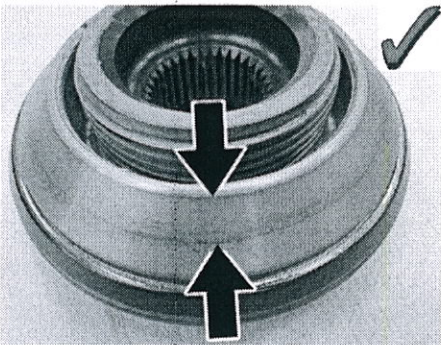
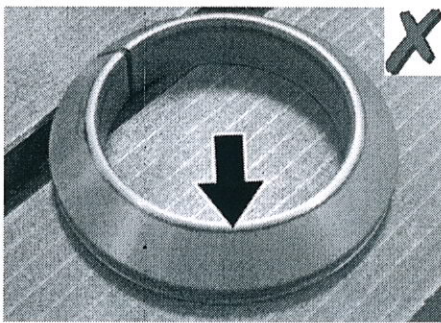
Assessment of cone ring on central bolt	
Looks normal for a vehicle that has been driven	Excessive signs of wear
<p><b>Wide contact pattern</b> → <i>Cone ring OK</i></p> <ul style="list-style-type: none"> <li>• There is no discoloration on the coating of a new cone ring on the central bolt.</li> <li>• After a certain mileage, a grey/black contact pattern that is <b>approx. 10-15 mm</b> wide forms, with the main pressure point in the centre <b>-arrows-</b> .</li> <li>• The complete surface is blackened on vehicles with high mileage.</li> </ul>	<p><b>Narrow line</b> → <i>Cone ring not OK</i></p> <ul style="list-style-type: none"> <li>• Only a narrow line can be seen on the small diameter of the cone ring on the central bolt <b>-arrow-</b> .</li> </ul>
 <p><i>Cone ring OK</i></p> <ul style="list-style-type: none"> <li>• <b>Additional picture:</b></li> </ul>	 <p><i>Cone ring not OK</i></p>

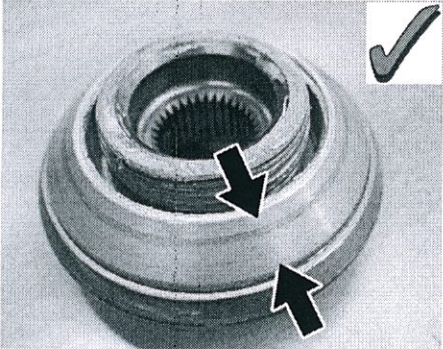
 <p style="text-align: center;">Cone ring OK (1)</p>	
<b>Result/Action required</b>	
⇒ The <b>wheel hub</b> does <b>not</b> have to be replaced.	⇒ The <b>wheel hub</b> must be replaced.

3. Check the wheel hub based on the appearance of the **wheel cone** ( → *Checking wheel cone* ).

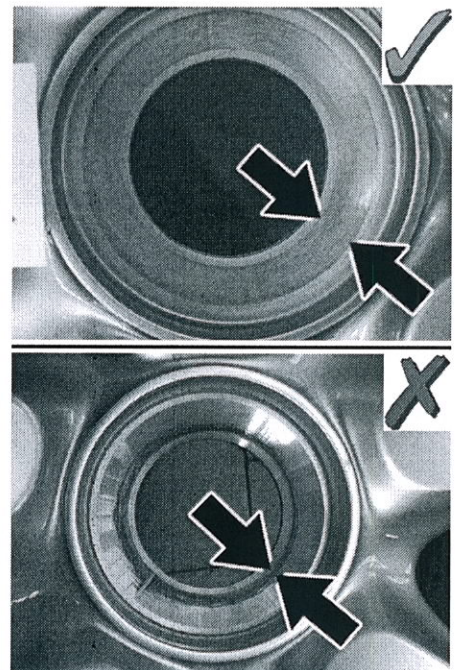

*Checking wheel cone*

<b>Wheel cone assessment</b>	
<b>Looks normal for a vehicle that has been driven</b>	<b>Excessive signs of wear</b>
<p style="text-align: center;"><b>Wide contact pattern</b> → <i>Wheel cone OK</i></p> <ul style="list-style-type: none"> <li>• After a certain mileage, an even contact pattern that is <b>approx. 10-15 mm</b> wide forms on the wheel cone <b>-arrows-</b> .</li> <li>• At first, this is just a shimmering surface, but the surface turns completely black on vehicles with higher mileage.</li> </ul>	<p style="text-align: center;"><b>Narrow contact pattern</b> → <i>Wheel cone not OK</i></p> <ul style="list-style-type: none"> <li>• Narrow (linear) contact pattern that is uneven or only in spots <b>-arrows-</b> .</li> </ul>

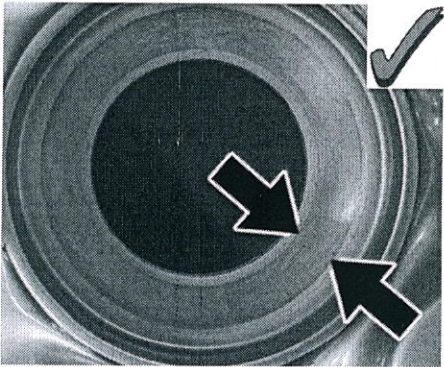
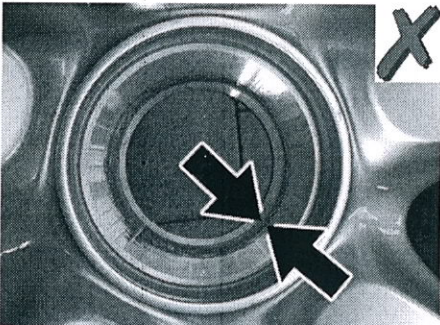
 <p style="text-align: center;">Wheel cone OK</p>	 <p style="text-align: center;">Wheel cone not OK</p>
<p><b>Result/Action required</b></p>	
<p>⇒ The wheel hub does <b>not</b> have to be replaced.</p>	<p>⇒ The <b>wheel hub</b> must be replaced.</p> <p>Checking the wheel cone is only an indirect way of checking the wheel hub.</p> <p>The actual <b>wheel</b> does <b>not</b> need to be replaced if the wheel cone looks like this.</p>

**Assessment of wheel adapters, wheel and brake disc**

1. **Check wheel adapters** → *Checking wheel adapters* .

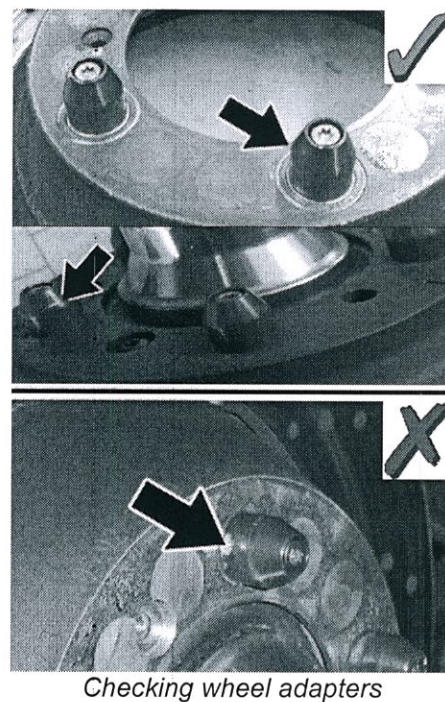

<p><b>Assessment of wheel adapters</b></p>	
<p><b>Look normal for a vehicle that has been driven</b></p>	<p><b>Excessive signs of wear</b></p>

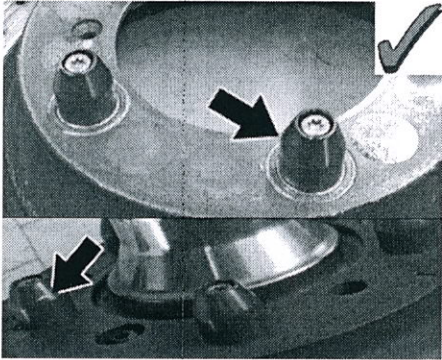
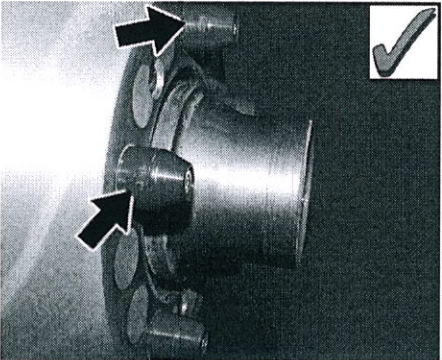
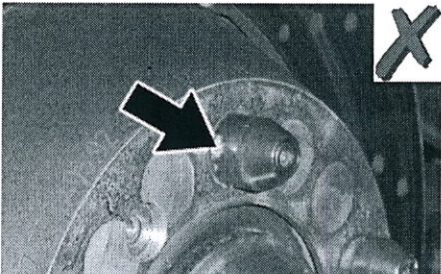
<p><b>Light scratches on the surface</b> → <i>Wheel adapters OK</i></p> <ul style="list-style-type: none"> <li>• There are light scratches on the surface of the wheel adapters <b>-arrows-</b> .</li> <li>• The scratches are caused by removing and fitting wheels and can be deeper scratches or just minor scrapes, depending on how often the wheel has been changed.</li> </ul>	<p><b>Eloxal coating is completely worn down in places</b> → <i>Wheel adapters not OK</i></p> <ul style="list-style-type: none"> <li>• The red Eloxal coating on the wide surface is completely worn down on the cylindrical surface of the wheel adapters <b>-arrow-</b> .</li> <li>• The wheel adapters must also be replaced if they can be turned by hand.</li> </ul>
 <p><i>Wheel adapters OK</i></p> <ul style="list-style-type: none"> <li>• <b>Additional picture:</b></li> </ul>  <p><i>Wheel adapters OK (1)</i></p>	 <p><i>Wheel adapters not OK</i></p>
<p><b>Result/Action required</b></p>	
<p>⇒ The <b>wheel adapters</b> do <b>not</b> have to be replaced.</p>	<p>⇒ The <b>wheel adapters</b> and <b>wheel hub</b> must be replaced.</p>

2. Check the contact surface for the brake disc on the **wheel** ( → *Checking wheel contact surface* ).

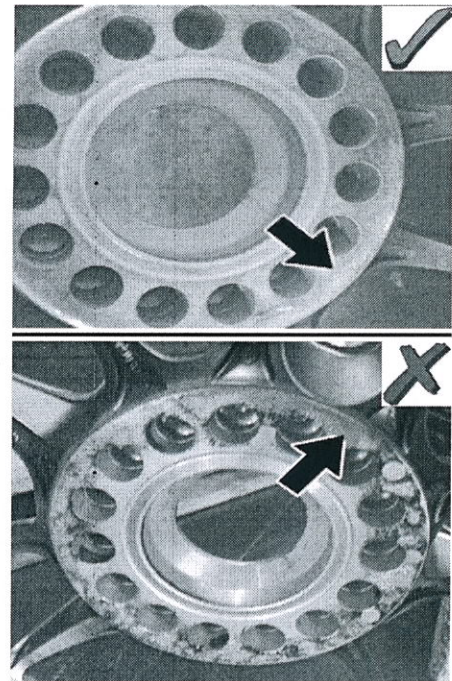

Checking wheel contact surface

Assessment of wheel contact surface	
<p><b>Looks normal for a vehicle that has been driven</b></p>	<p><b>Excessive signs of wear</b></p>
<p><b>Discolouration or slight irregularities on the surface</b> → <i>Wheel contact surface OK</i></p> <ul style="list-style-type: none"> <li>• Discolouration or slight irregularities on the surface due to the slightest movements while driving (micro-movements) are OK <b>-arrow-</b> .</li> <li>• The contact surface is smooth (flat).</li> <li>• Material is not worn down.</li> </ul>	<p><b>Material erosion</b> → <i>Wheel contact surface not OK</i></p> <ul style="list-style-type: none"> <li>• There is material erosion on the outer edge <b>-arrow-</b> of the wheel contact surface.</li> <li>• The edge is worn down (eroded) so much that there is a radius on the outer edge <b>-arrow-</b> .</li> <li>• The wheel contact surface is uneven.</li> <li>• Signs of wear can also be seen on the <b>wheel hub</b> and <b>brake disc</b> in accordance with the relevant description.</li> </ul>
<div data-bbox="261 1536 705 1856" data-label="Image"> </div> <p><i>Wheel contact surface OK</i></p> <ul style="list-style-type: none"> <li>• <b>Additional picture:</b></li> </ul>	<div data-bbox="895 1536 1340 1877" data-label="Image"> </div> <p><i>Wheel contact surface not OK</i></p>



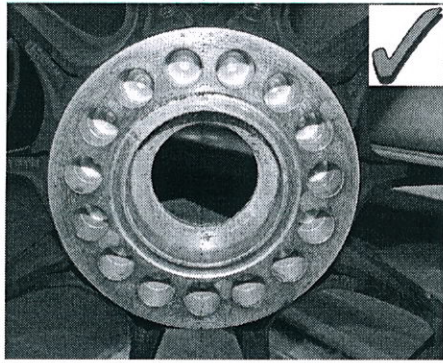

Wheel contact surface OK (1)

Result/Action required	
<p>⇒ The <b>wheel</b> does <b>not</b> have to be replaced.</p>	<p>⇒ The <b>wheel</b> and <b>wheel hub</b> must be replaced.</p> <p>⇒ If there are visible signs of wear on the <b>brake disc</b> in accordance with the description below, the brake disc must also be replaced.</p>

3. Check the contact surface for the wheel on the **brake disc** ( → *Checking brake disc* ).

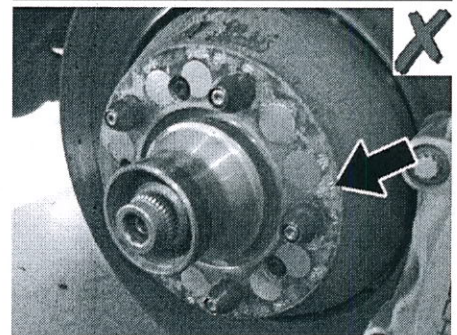
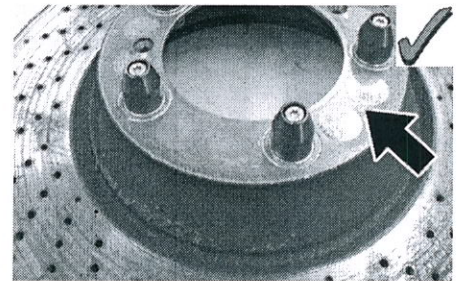

Checking brake disc

Brake disc assessment	
<p><b>Looks normal for a vehicle that has been driven</b></p>	<p><b>Excessive signs of wear</b></p>
<p><b>Discolouration or slight irregularities on the surface</b> → <i>Brake disc OK</i></p>	<p><b>Material erosion</b> → <i>Brake disc not OK</i></p>

- Discolouration or slight irregularities on the surface due to the slightest movements while driving (micro-movements) are OK **-arrow-** .
- The contact surface is smooth (flat).
- Material is not worn down.

- Material erosion and some crater-shaped cracks can be seen on the wheel contact surface **-arrow-** .
- The contact surface is uneven.

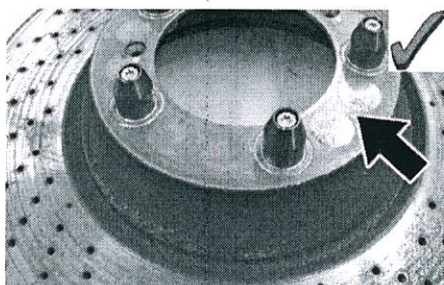

Brake disc OK

- **Additional picture:**

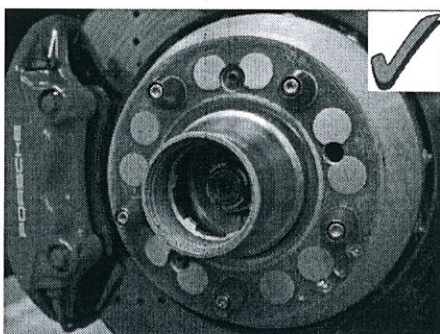

Brake disc OK (1)

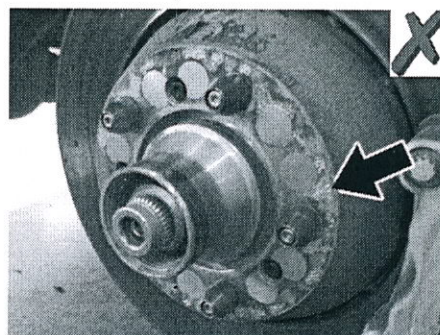

Brake disc not OK

**Result/Action required**

⇒ The **brake disc** does **not** have to be replaced.

⇒ The **brake disc, wheel adapters and wheel hub** must be replaced.

⇒ If there are visible signs of wear on the **wheel contact surface** in accordance with the previous description, the **wheel** must also be replaced.

991140, 991141, 991160, 991161, 991340, 991341, 991360, 991361, 991430, 991431, 991440, 991441, 991450, 991451, 991460, 991461, 991540, 991541, 991630, 991631, 991640, 991641, 991650, 991651, 991660, 991661, 991810, 991811, 991850, 991851, 991880, 991881

Model year as of 2014

C00, C02, C05, C06, C07, C08, C09, C10, C11, C12, C13, C14, C15, C16, C17, C18, C19, C20, C21, C22, C23, C24, C25, C26, C27, C28, C32, C33, C34, C35, C36, C37, C38, C39, C41, C45, C46, C96, C97, C98, C99

# WM 4X00IN Specifications and revision intervals for race track use - vehicles with central wheel lock

## Information

### Information

The race track usage profile of many vehicles in the 911 model line now comes close to that of pure GT3 racing vehicles (e.g. GT3 Cup).

The component stresses associated with race track use and competitive driving are much higher than for a sporty driving style on public roads.

The following specifications and revision intervals for race track use must therefore be observed, particularly for highly stressed chassis components, in the same way as is required for GT3 racing vehicles.

The specifications for race track use described in the Driver's Manual are elaborated further by the following specifications and revision intervals for race track use. Findings from motor racing are incorporated into the usage specifications on an on-going basis.

**Revision intervals for race track use are different for 911 GT3 (991) and 911 GTS/Turbo (991) vehicles.**

### General specifications for race track use (911 GTS/Turbo and 911 GT3)

1. Always check the central wheel lock **before** using the vehicle for intensive driving on the race track.  
→ 440702 *Checking central lock on wheels.*

Checking includes the following checks (list):

- Remove wheel bolts and remove wheels. → 440519 *Removing and installing wheel with central bolt.*
- Check components of the central wheel bolts (wheel bolts, wheel contact surfaces (wheel and wheel hub), check that wheel driver pins are fitted securely, lockable wheel bolt).
- Grease conical surface of the central bolt with a **very light coating** of Optimoly TA (aluminium grease) before fitting each wheel.
- Also grease thread in the wheel hub with a little Optimoly TA (aluminium grease).
- Re-fit wheels according to instructions. Tighten central wheel bolts to the specified **tightening torque of 600 Nm (444 ftlb.)** (using 3-step tightening procedure) and check that the locking pin has engaged correctly in the central bolt. For details, see → 440519 *Removing and installing wheel with central bolt.*

2. Always complete the following steps **after** driving the vehicle on a race track:

- Tighten threaded connection securing drive shaft to wheel hub (M22 x 1.5) to the specified **tightening torque of 460 Nm (340 ftlb.)**.
- Check all central wheel lock components for signs of wear and replace them if necessary. → *Central wheel lock: component assessment.*

### Revision intervals for race track use - 911 GT3

At present, the following **revision intervals** are stipulated for **race track use for the 911 GT3 (991)**:

**At the latest, every 10,000 km/6,000 miles for race track use (cumulative)**

Replace all central wheel lock bolts.

→ 440519 *Removing and installing wheel with central bolt*

Replace wheel hubs and wheel bearings on rear axle.

→ 425819 *Removing and installing rear wheel bearing*

**At the latest, every 20,000 km/12,000 miles for race track use (cumulative)**

Replace all central wheel lock bolts.

→ 440519 *Removing and installing wheel with central bolt*

Replace wheel hubs and wheel bearings on front axle.

→ 405719 *Removing and installing front wheel bearing*

Replace wheel hubs and wheel bearings on rear axle.

→ 425819 *Removing and installing rear wheel bearing*

The special design of the wheel bearing housing/wheel bearing means that the wheel bearing housing does not need to be replaced.

991140, 991141, 991430, 991431, 991440, 991441, 991450, 991451, 991540, 991541, 991630, 991631, 991640, 991641, 991650, 991651, 991810, 991811, 991850, 991851, 991880, 991881

Model year as of 2014

C00, C02, C05, C06, C07, C08, C09, C10, C11, C12, C13, C14, C15, C16, C17, C18, C19, C20, C21, C22, C23, C24, C25, C26, C27, C28, C32, C33, C34, C35, C36, C37, C38, C39, C41, C45, C46, C96, C97, C98, C99