

# The new Cayman GT4 Clubsport

REBELS RACE HARDER





# Content

**Basic concept & targets of the  
Cayman GT4 Clubsport project**

**Technical Details**

**Additional Features**

# The Guideline for the Cayman GT4 Clubsport

*“As close as possible to the series,  
where necessary fitted with DNA of Motorsport ”*



# Roots

2006 – Cayman  
(Type 987)



2013 – Cayman  
(Type 981)



2015 – Cayman  
GT4 (Type 981)



2015 – Cayman  
GT4 Clubsport  
(Type 981)



# GT Sports - Technology Transfer

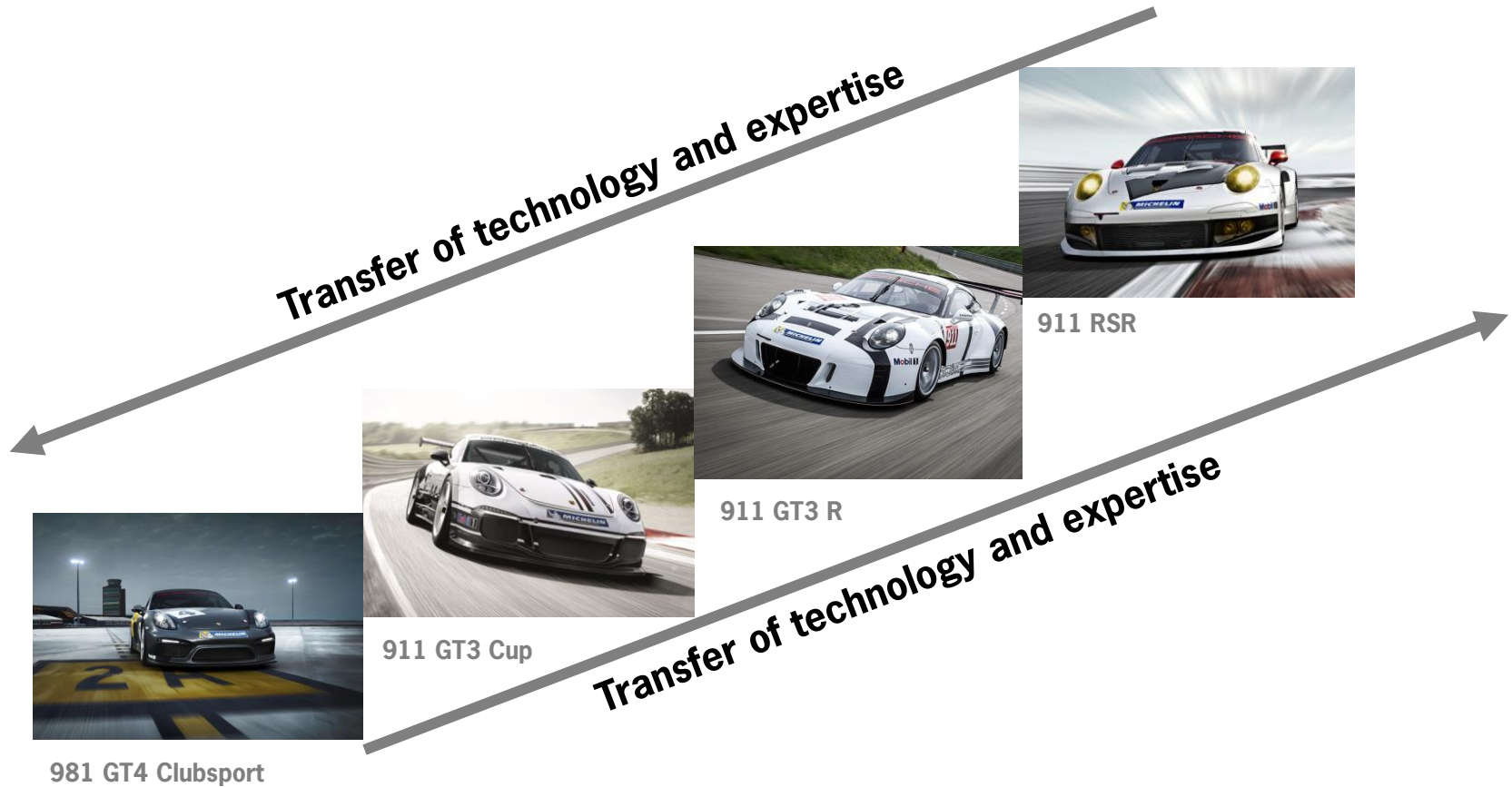

# The Porsche Motorsport Pyramid

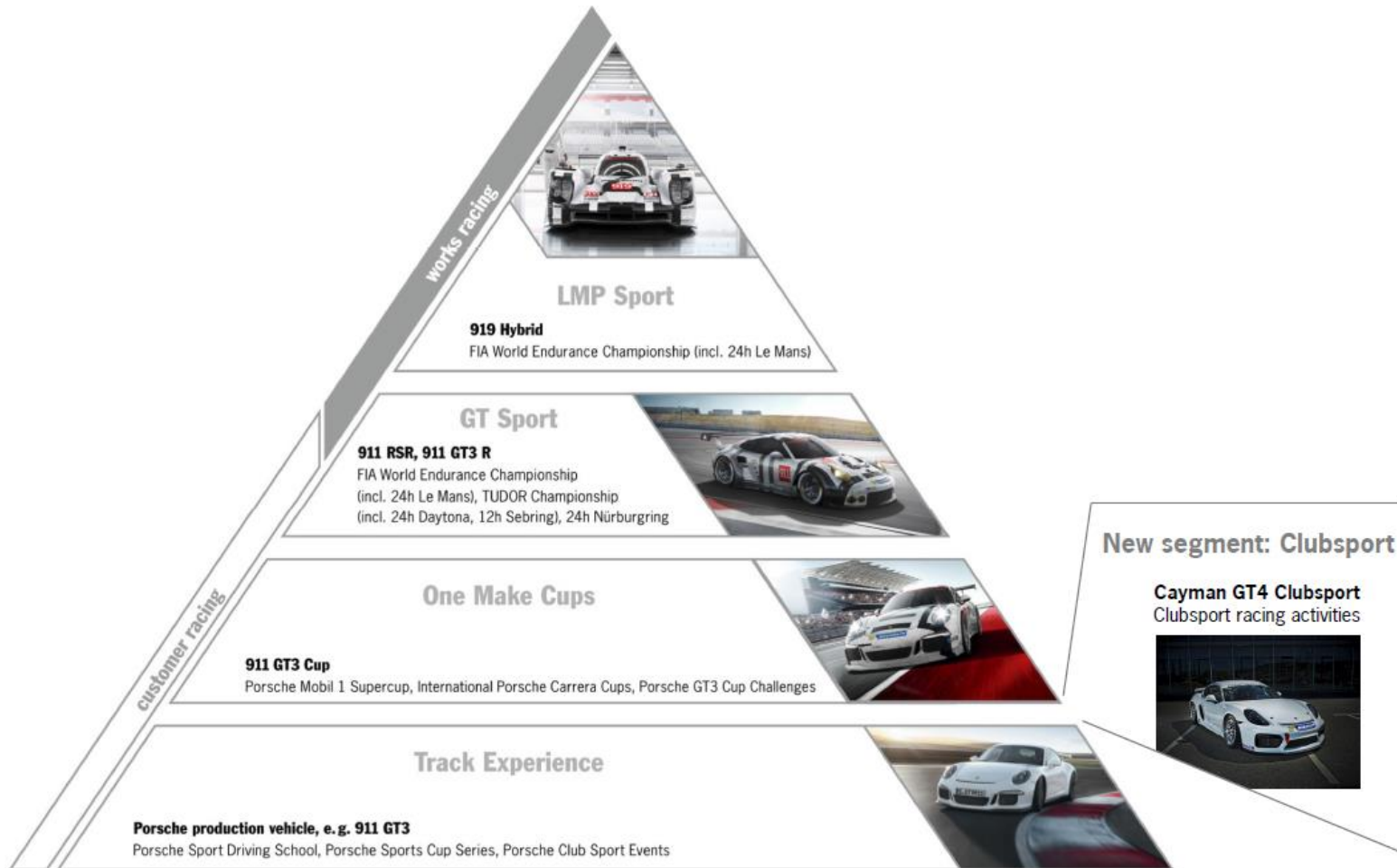

# Master Plan

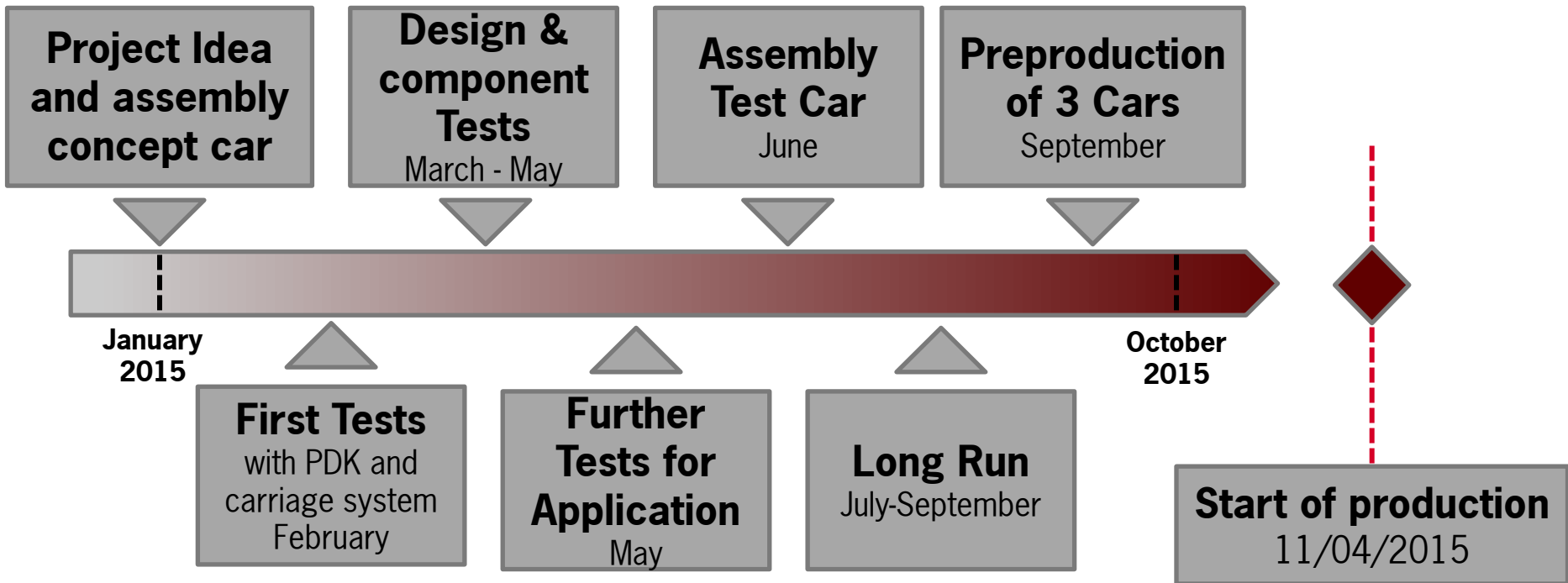



# Driven Mileage (during long run test)

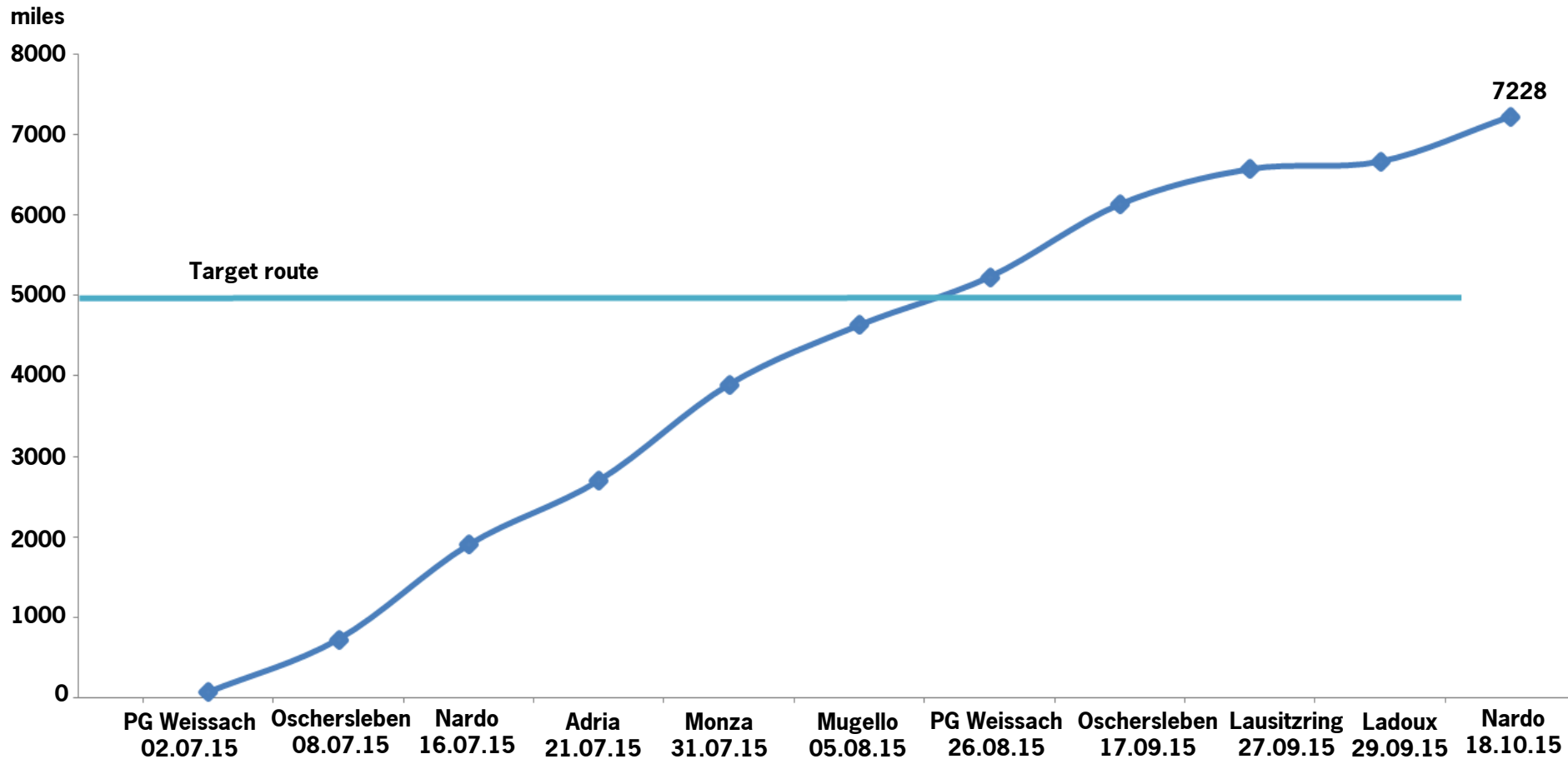

# Lap Times

Race Track	Lap Times (in minuntes)	Reference Time
Monza	1.58.68	2.00.00
Nardo	2.20.85	2.22.00
Oschersleben	1.34.67	1.35.00
Adria	1.21.29	1.21.00

# Combustion Engine

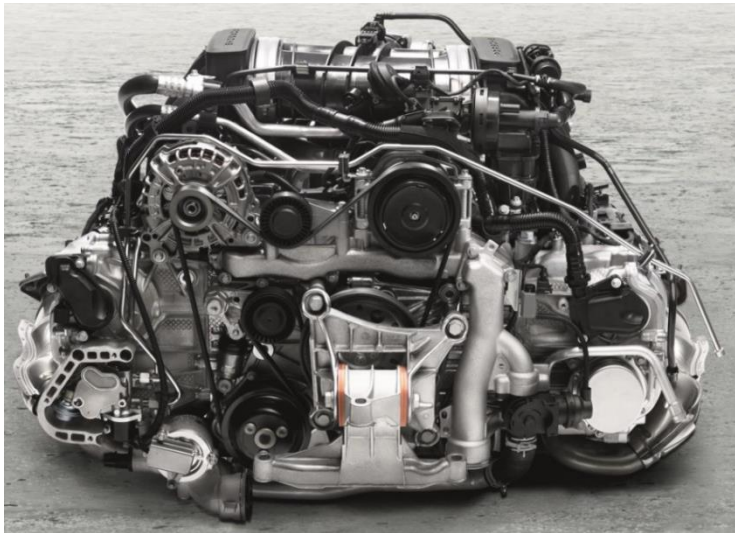

## Key Facts

- Boxer 6-cyl 3.8l 24 V
- $P_{\max}$  385 hp (283 kW) @ 7.400 rpm
- $M_{\max}$  420 Nm @ 4.750 - 5800 rpm
- Max. speed 7.800 rpm
- Integrated dry sump lubrication system
- Flow optimized sport exhaust system
- 100 cell metal catalytic converter
- rigid mounting

# Dual Clutch Transmission



## Key Facts

- 6 speed dual clutch transmission (modified PDK with the differential lock from the Boxster 2.7)
- Rigid transmission mounts

# System/ Electrical

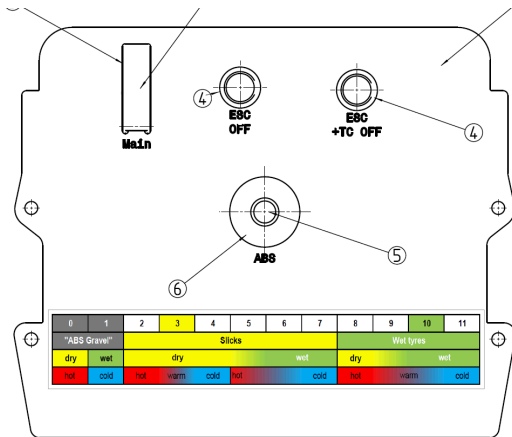

## Key Facts

- Race car optimized wiring harness of 981 GT4
- AGM battery 12V/ 70 Ah/ 450 A
- Switch plate on center console
- ABS S12 switch (wet, dry)
- Standard headlights from a 981 Cayman
- Possibility to switch off the PSM in 2 steps
- Preparation for Track Precision APP
- No parking brake
- Main switch

# Axles (front)

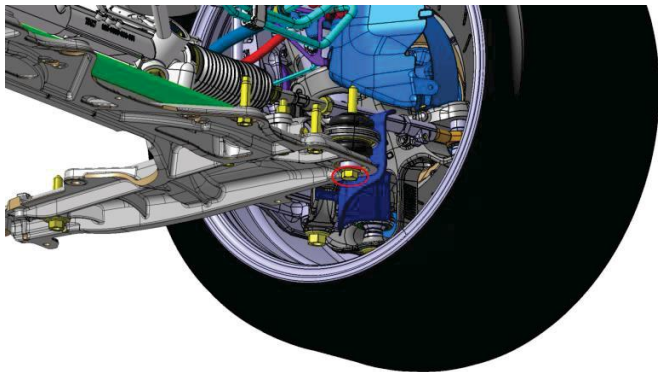

## front axle

- Lightweight damper strut with wishbone and tie rod from the 991 GT3 CUP for higher stability and higher wheel load capacity
- New antiroll bar
- Improved wheel bearings
- 9x18"/5-hole forged-rims
- Race specific dual-circuit hydraulic brake system with 380 mm ventilated steel brake discs and integral 6-Piston-aluminum-brake calipers
- Springs: 200-140
- Race optimized electromechanical steering from GT4 road car

# Axles (rear)



## rear axle

- Lightweight suspension from GT4 road car
- Reinforced damper strut and tie rod
- Improved wheel bearing
- GT3 Cup braking system
- Rear wheel drive
- Driveshaft from 991 GT3
- 10.5x18"/ 5-hole forged-rims
- Race specific dual-circuit hydraulic brake system with 380 mm ventilated steel brake discs and integral 4-Piston-aluminum-brake calipers
- Spring: 220-140

# Set Up

Höhe (Slick 2bar) Siehe Kapitel 0.4.2 Messpunkte der Fahrzeughöhe	VA li.	79 mm	VA re.	79 mm
	HA li.	105 mm	HA re.	105 mm
Stabi pos.	VA	2 (mitte)		
	HA	2 (mitte)		
Sturz (deg min)	VA li.	-3°50'	VA re.	-3°50'
	HA li.	-3°10'	HA re.	-3°10'
Spur (min)	VA li.	+0,02°	VA re.	+0,02°
	HA li.	0°17'	HA re.	0°17'
Feder	VA Haupt	200-140	VA Help	10/60/80
	HA Haupt	220-140	HA Help	10/60/80
Dämpfer	VA KW fix			
	HA KW fix			
Radstand	Links	2472 mm	Rechts	2472 mm



# Tire Sizes

	Slick	Rain
As delivered, Front Axle		24/64-18
As delivered, Rear Axle		27/68-18
Recommended, Front Axle	25/64-18	24/64-18
Recommended, Rear Axle	27/68-18	27/68-18

# Body

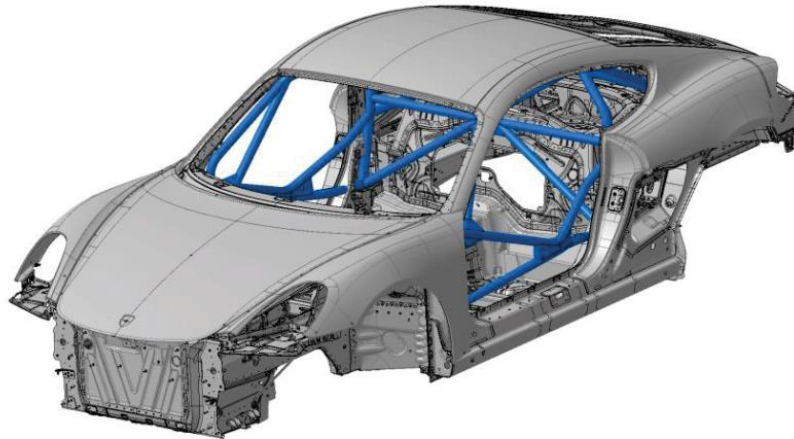

## Key Facts

- Based on Cayman GT4
- Welded roll cage (FIA approved)
- Outside positioned door bars
- Front body prepared for larger tank volume
- Tow straps/ hooks (§227 FIA)
- Hand fire extinguisher
- Preparation for extinguishing system
- Preparation for air jack system
- Length: 4.438 mm
- Breadth: 1.978 mm (FA)/ 2.002 mm (RA)
- Weight: 1.300 kg (2.860 lbs..)



21.11.2015

Cayman GT4 Clubsport

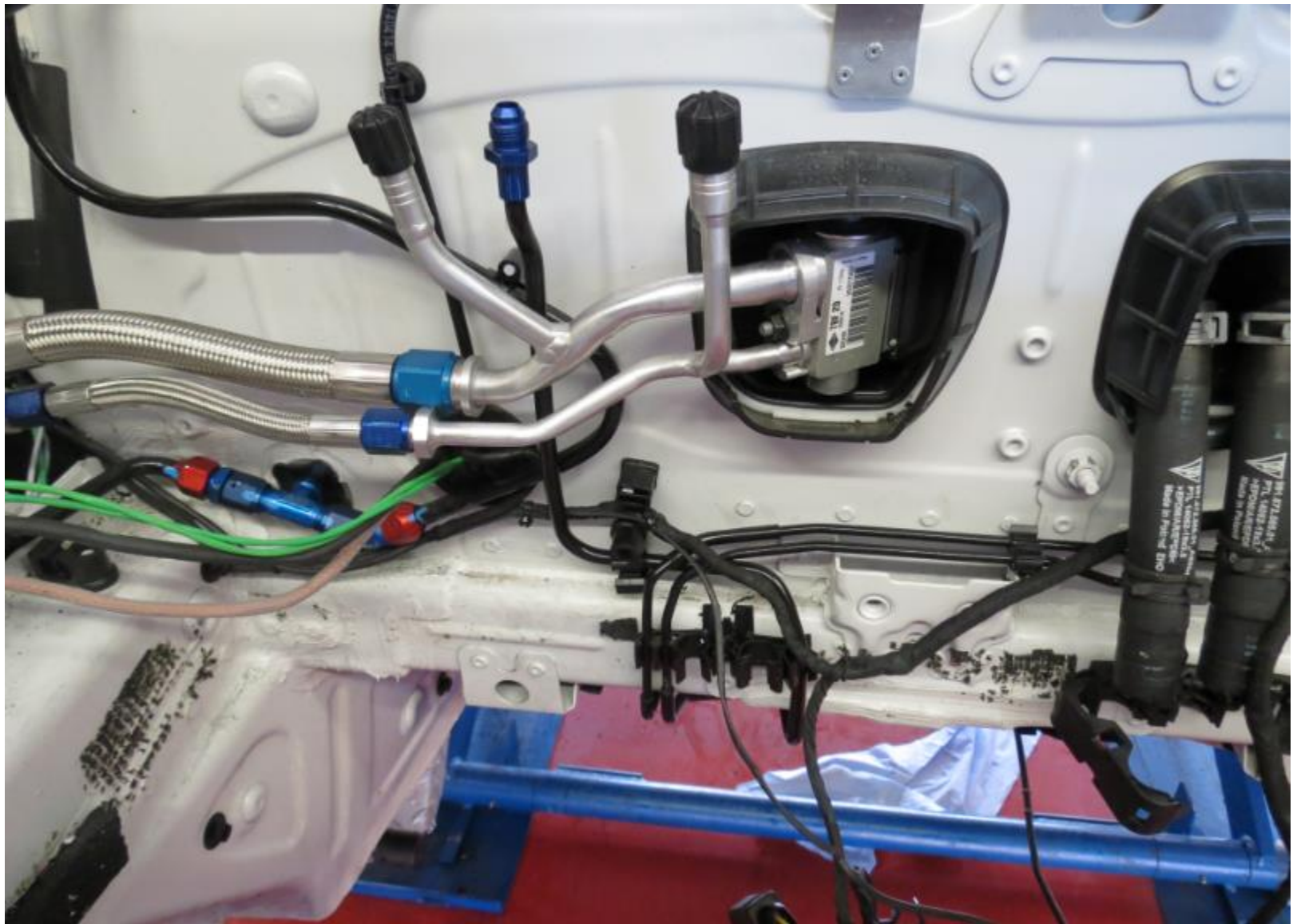

21.11.2015

Cayman GT4 Clubsport



21.11.2015

Cayman GT4 Clubsport



# Fuel Tank

70l (18.5 gal)  
FT3 Tank  
(Aluminum)  
20 kg (44 lbs.)

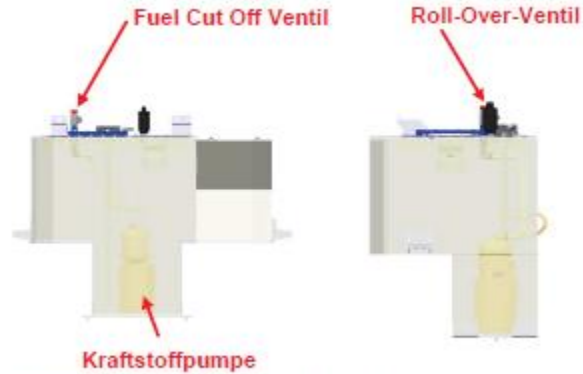

100l (24.4 gal)  
FT3 Tank (CfK)  
15,5 kg (13,4 lbs.)

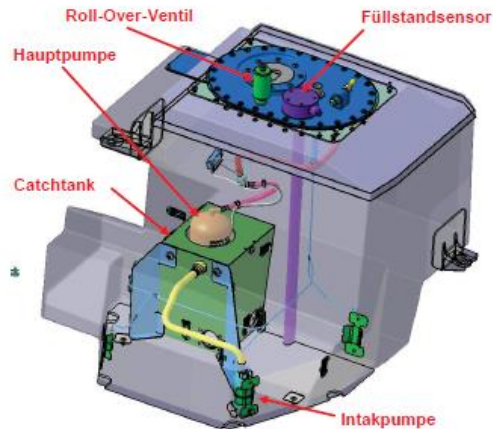

# Fuel Tank

Tank variation	Series	FT3 70 Liter	FT3 100 Liter
Tank capacity	90	70	100
Brake power booster	X	X	-
Brake master cylinder of 991 GT3 Cup	-	-	X
Fuel pump with supply Unit	-	-	X
Cable loom fuel tank Fuel pump ECU/FT3	-	X	X
Underride guard	Series	X	X
Covering and installation frame			X
Sub frame FA GT4	X	-	-
Sub frame FA 911 GT3 Cup	-	X	X
Fuel hose with drain coupling FT3 70 L	-	X	-
Fuel hose with drain coupling FT3 100 L	-	-	X



# Steering Wheel

## GT4 Road Car

- Standard steering wheel with shift paddles and steering wheel rim of Alcantara



## GT4 Clubsport

- Racing steering wheel with shift paddles of carbon fiber



# Seat

## GT4 Road Car

- Optional CFRP bucket seat with carbon-weave finish
- upholstered in black leather as standard with seat centers in Alcantara



## GT4 Clubsport

- Optional CFRP Recaro bucket seat from 991 GT3 Cup
- 6-point harness
- FIA certified



# Rear Wing

## GT4 Road Car

- Original GT4 rear wing



## GT4 Clubsport

- Carbon fiber rear wing with gurney flap 10 mm for more downforce
- Adjusted at Po. 1°



# Interior

## GT4 Road Car

- Original GT4 interior with many Alcantara features
- PCM audio system



## GT4 Clubsport

- Radical motorsport interior with series OMP seat
- No PCM



# Interior

## GT4 Road Car

- Original GT4 door panel
- door openers are belt straps



## GT4 Clubsport

- Lightweight motorsport door panel made of carbon fiber
- door openers are belt straps



# GT4 Clubsport vs. GT4 Road Car

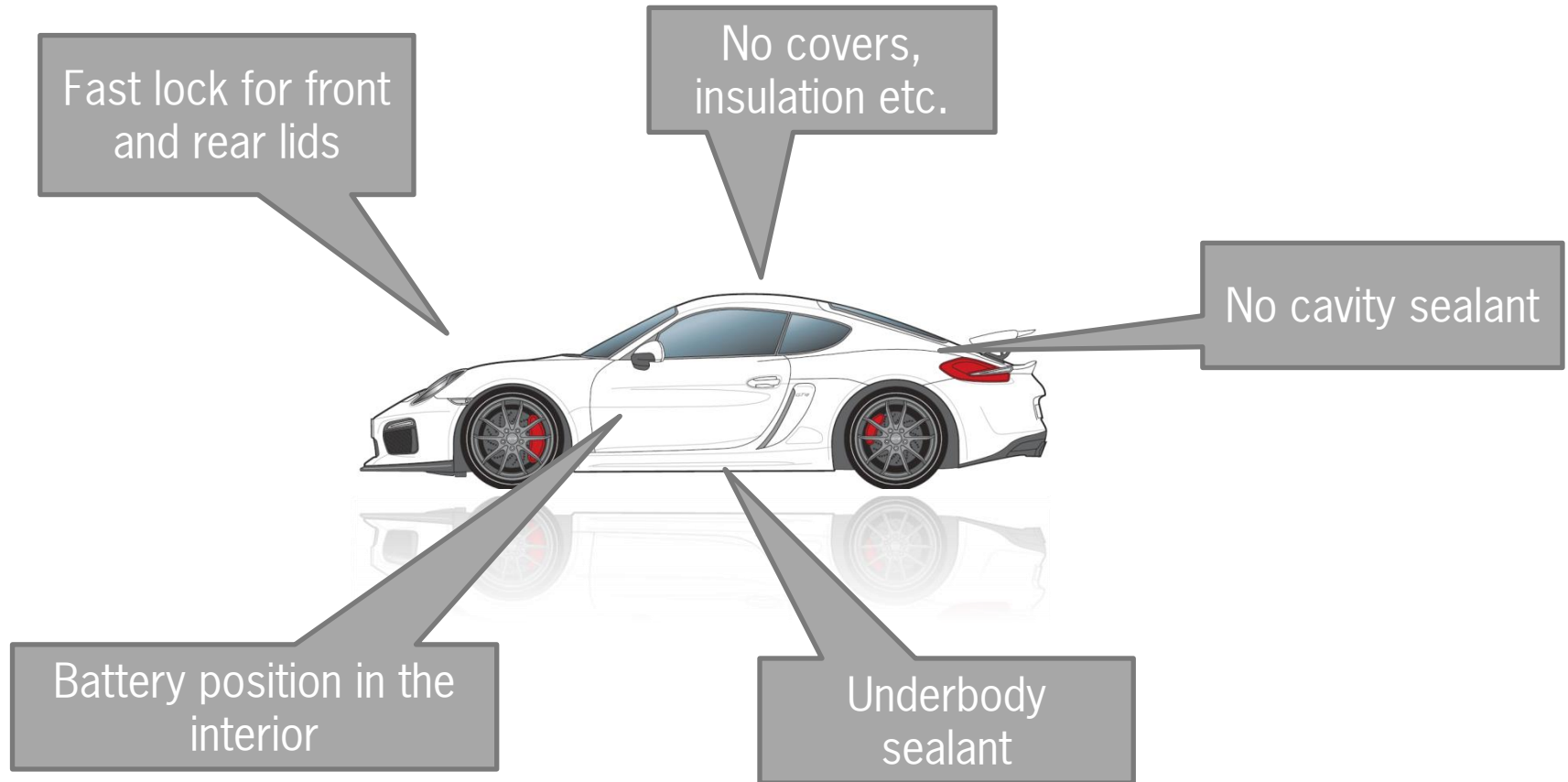

# ABS MAP Switch



0	1	2	3	4	5	6	7	8	9	10	11
„ABS Gravel“		Slicks						Wet tires			
dry	wet	dry			wet			dry		wet	
hot	cold	hot	warm	cold	hot	cold		hot	warm	cold	

# Track Precision App

Live Views	Analysis
<ul style="list-style-type: none"> <li>Track recording with GPS-Lap timer and visualize driving dynamics</li> <li>Comparative display „Ghost Car“</li> </ul>	<ul style="list-style-type: none"> <li>Video recording with driving data</li> <li>GPS trend</li> </ul>
Evaluation	Exchange
<ul style="list-style-type: none"> <li>Race statistics</li> <li>Analysis of the track/lap Speed curve with time projection:</li> <li>-Along crosswise acceleration</li> <li>Over-/under drive</li> <li>Driver action</li> <li>Consumption per lap</li> </ul>	<ul style="list-style-type: none"> <li>Profile and statistics</li> <li>Race track administration</li> <li>Exchange of the records</li> <li>Export of the PC-Software</li> </ul>

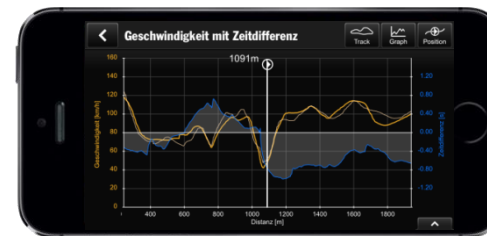



# Summary



*Cayman GT4*

**From the street to  
the race track**



*Cayman GT4 Clubsport as  
basic model  
limited for 360 vehicle*



Preparable for e.g.:

- GT4 European Series SRO
- 24h Dubai
- Porsche Club of America
- Pirelli GT3 Cup Trophy
- Ultra 94 GT3 Cup Challenge Canada
- Continental Tire SportsCar Challenge Sportscup
- Etc.



but there is one more



thing

# Additional features by Manthey Racing or After Sales

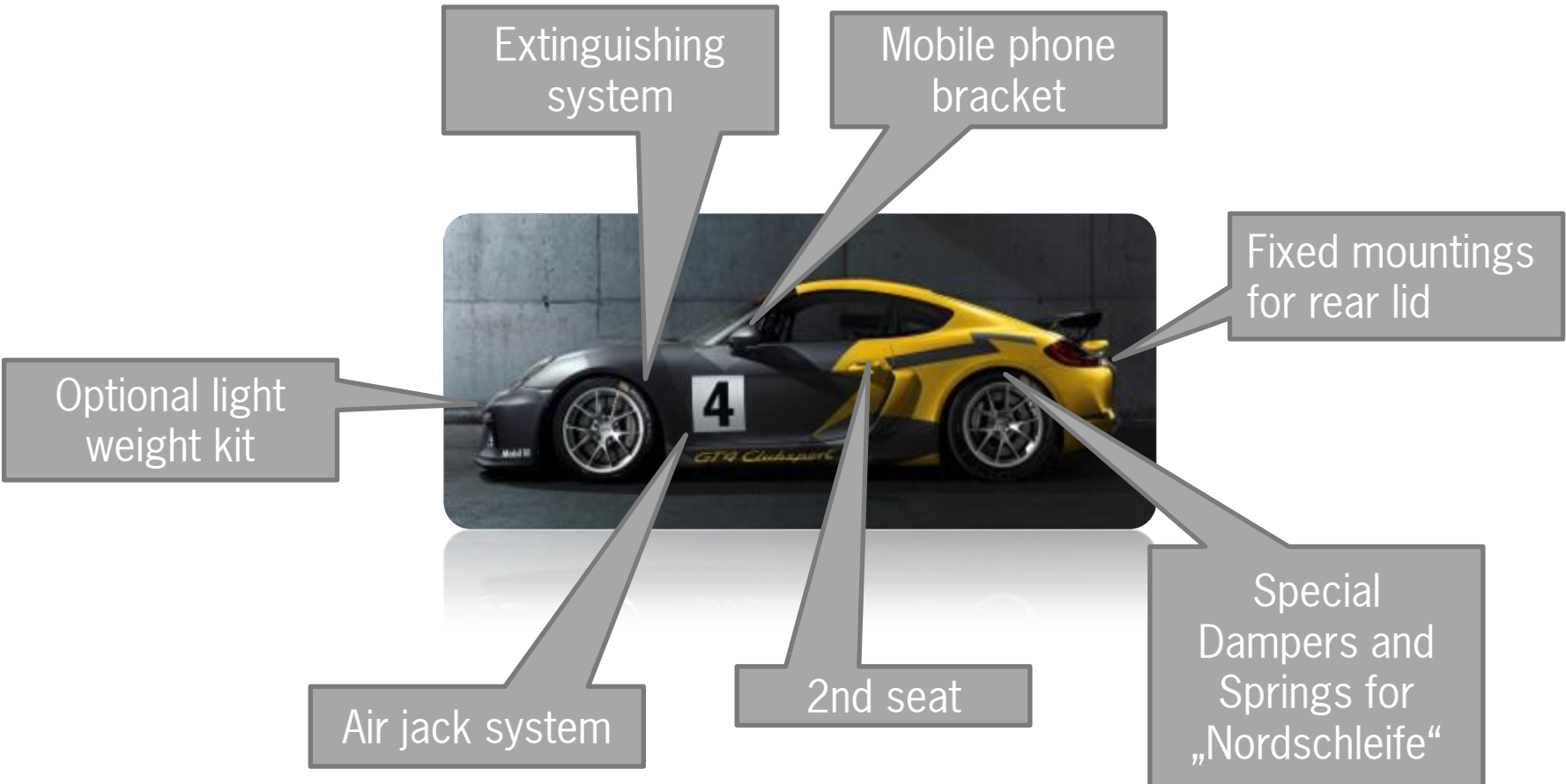



Thank you

