

**Wheel Clearance for Race Track Use**



**Information**

This Technical Information replaces the previous TI dated June 6, 2016.

**Additions compared to the previous TI:**

- Section ⇒ *Technical Information '4X0000 Fitting spacers on the spring struts on the rear axle'* was added

Vehicle Type: **911 GT3 RS (991)**

Model Year: **As of 2015 up to 2016**

Subject: **Wheel clearance for race track use**

Information: **The chassis of the 911 GT3 RS and the chassis settings implemented at the factory are designed for maximum performance. The vehicle's performance potential is supported by wider wheels and tires, including the larger 21-inch wheel diameter on the rear axle.**

Observations have shown that the chassis still shows a certain amount of settling behavior within the first 3,700 miles (6,000 km).

During performance-oriented driving on a race track – particularly if the vehicle is frequently driven at its performance limits – combined with chassis setup tolerances, this can quickly cause the wheels to come into contact with peripheral components.

Remedial Action: In order to improve the required wheel clearance even under extreme conditions (e.g. driving through compressed areas on the race track), there are various measures available for making the vehicle more robust.

Please inform customers who use their vehicle on race tracks about these measures.

**Measures for the entire vehicle**

- Fit spacers on the piston rods of the spring struts on the rear axle. For instructions, see section ⇒ *Technical Information '4X0000 Fitting spacers on the spring struts on the rear axle'* in this Technical Information.
- Perform suspension alignment. Make sure that the **height is never less than the required vehicle height at front and rear axle**. For instructions, see section ⇒ *Technical Information '4X0000 Performing suspension alignment and adjusting vehicle height if necessary'* in this Technical Information.

**Measures for front axle**

- **Remove upper grilles in the wheel housing liners** at the left and right **for driving the vehicle on the race track** in order to prevent possible contact between tire and grill under extreme conditions. **Re-install the grills before driving on public roads**. For instructions, see section ⇒

*Technical Information '4X0000 Removing grilles in the wheel housing liners on the front axle'* in this Technical Information.

#### Measures for rear axle

- Rework wire harness for rear axle steering at the left and right to prevent any possible contact between the tires and wire harness for rear axle steering under extreme conditions. For instructions, see section ⇒ *Technical Information '4X0000 Reworking wire harness for rear axle steering'* in this Technical Information.
- Flare the wheel arch on the rear side panel over an extended area to prevent possible contact between the tire and front area of the wheel arch under extreme conditions during which the rear axle steering is turned in sharply. For instructions, see section ⇒ *Technical Information '4X0000 Reworking side panel (wheel arch)'* in this Technical Information.



#### Information

If the **vehicle is used for driving on race tracks**, we recommend that the **measures are carried out as a preventative step** in consultation with the customer.

Before flaring the wheel arch as a preventative measure, please inform the customer regarding possible risks associated with implementation, e.g. the possibility of cracks appearing in the paint surface and the possible need to spot-paint the affected area. This will assure that the customer understands the risks and benefits before deciding whether or not to go ahead with this preventative measure.

#### Fitting spacers on the spring struts on the rear axle

Parts Info:	Part No.	Designation	Qty.
	991 333 955 80	⇒ Spacer	2 ea.

#### Work Preparatory work

Procedure: 1 Raise the vehicle on a lifting platform ⇒ *Workshop Manual '4X00IN Lifting the vehicle'*

#### Fit spacer on the rear spring strut at the left and right

- 1 Press the bellows ⇒ *Fitting spacer -1-* upwards with your hand ⇒ *Fitting spacer -arrow A-* until the piston rod ⇒ *Fitting spacer -3-* of the spring strut is visible. Hold the bellows in position with your hand.
- 2 Press spacer ⇒ *Fitting spacer -2-* onto the piston rod ⇒ *Fitting spacer -3-* (⇒ *Fitting spacer -arrow B-*) until it engages securely.
- 3 Release the bellows ⇒ *Fitting spacer -1-* again and align it with the concave washer.
- 4 Repeat steps 1 to 3 on the other side of the vehicle.

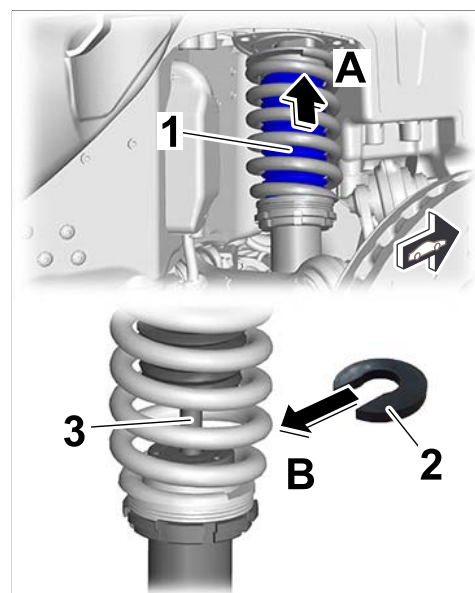

*Fitting spacer*

**Concluding work**

- 1 Remove the vehicle from the lifting platform.

**Performing suspension alignment and adjusting vehicle height if necessary**

Work Procedure: Perform suspension alignment. Make sure that the **height is never less than the required vehicle height at front and rear axle** as specified below.

Re-adjust the vehicle height if necessary.

Vehicle height	Adjustment value	Measurement reference
Front axle (20-inch wheels)	115 mm ± 2 mm	From road contact surface to measuring point on cross member/bulkhead ⇒ <i>Measuring point for front-axle height -arrows-</i>
Rear axle (21-inch wheels)	275 mm ± 2 mm	From road contact surface to locating bore in rear-axle side section ⇒ <i>Measuring point for rear-axle height -arrow-</i>

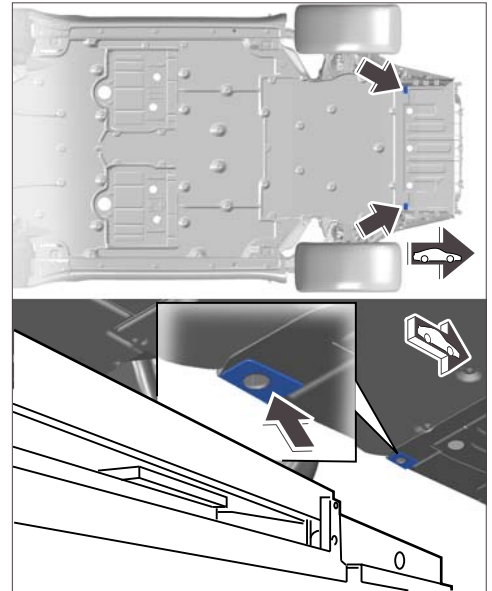

*Measuring point for front-axle height*

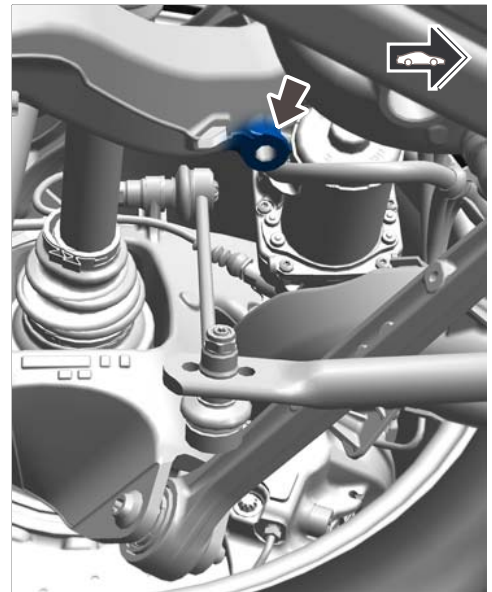

*Measuring point for rear-axle height*



**Information**

Due to the significant effect on handling and the low-tolerance wheel clearance designed to achieve maximum performance, particularly on the 911 GT3 RS, we generally recommend that you carry out a regular check on all chassis settings by performing suspension alignment.

For further details about suspension alignment and adjustment as well as measurement reference points, see

⇒ *Workshop Manual '449503 Suspension alignment, complete'*

⇒ *Workshop Manual '4495TW Adjustment values for suspension alignment'*

**Removing grills in the wheel housing liners on the front axle**



**Information**

**Exclusively for race track use**, the wheel clearance can be increased further on the front axle of the 911 GT3 RS by removing the upper grills in the wheel housing liners at the left and right, thereby preventing possible contact between the tire and grill under extreme conditions.

- The **removal of the grills** is **only permitted when driving on roads that are closed to public traffic** due to the legally required wheel cover.
- The grills help prevent road debris from passing through the opening and therefore must always be **reinstalled before use on public roads**.

Work Procedure: 1 Remove grills in the front wheel housing liners.

- 1.1 Loosen fastening screws ⇒ *Grill in wheel housing liner -A-* and remove the grills.
- 1.2 After removing the grills, screw the fastening screws in again and tighten them in order to secure the wheel housing liners correctly. **Tightening torque 2 Nm (1.5 ftlb.)**

2 Install grills in the front wheel housing liners.

- 2.1 Unscrew fastening screws.
- 2.2 Position grill in the wheel housing liner. Use new fastening screws if necessary (Part No. 999 073 505 01).
- 2.3 Screw in and tighten fastening screws. **Tightening torque 2 Nm (1.5 ftlb.)**

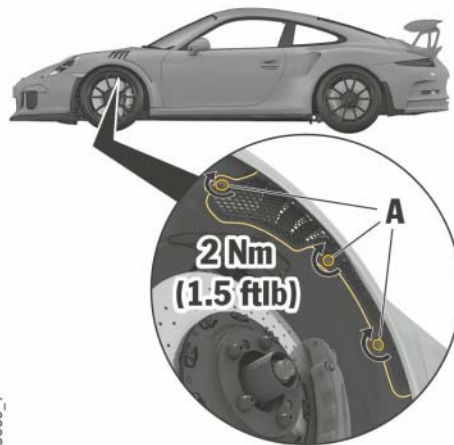

*Grill in wheel housing liner*

**Reworking wire harness for rear axle steering**

Parts Info:	Part No.	Designation	Qty.
	95B 971 820 A	⇒ Anti-chafing element (woven)	2 ea.
	955 606 838 00	⇒ Tie-wrap holder	2 ea.

Materials: Required materials – usually available in the Porsche Dealership:

Part No.	Designation	Qty.
...	Textile insulating tape	As required

Work

**Preparatory work**

Procedure:

- 1 Remove wheel with central bolt ⇒ *Workshop Manual '440519 Removing and installing wheel with central bolt'*.
- 2 Remove rear wheel housing liner ⇒ *Workshop Manual '536919 Removing and installing rear wheel housing liner'*.

**NOTICE****Tie-wraps not cut correctly**

- Risk of damage to electric wires
  - Risk of damage to insulation or protective sleeve on wire harness
- ⇒ Carefully cut tie-wraps using suitable side cutters when removing the wire harness.
- ⇒ Cut tie-wraps only in the fastening point area.

**Reworking wire harness for rear axle steering**

- 1 Disconnect wire harness for rear axle steering.
  - 1.1 Carefully cut tie-wrap ⇒ *Disconnecting wire harness for rear axle steering -1-* and remove wire harness ⇒ *Disconnecting wire harness for rear axle steering -2-* from the bracket.
  - 1.2 Remove plug connections for wire harness ⇒ *Disconnecting wire harness for rear axle steering -2-* from the bracket ⇒ *Disconnecting wire harness for rear axle steering -arrows-*.
  - 1.3 Lever off tie-wrap holder ⇒ *Disconnecting wire harness for rear axle steering -1-* on the wire harness bracket and dispose of it.

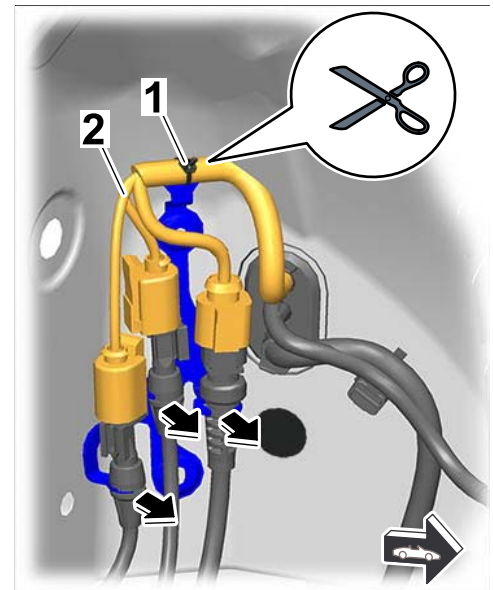

*Disconnecting wire harness for rear axle steering*

- 2 Bend bracket ⇒ *Bending bracket -1-* forward by approx. 35° as shown using suitable pliers ⇒ *Bending bracket -arrow-*.

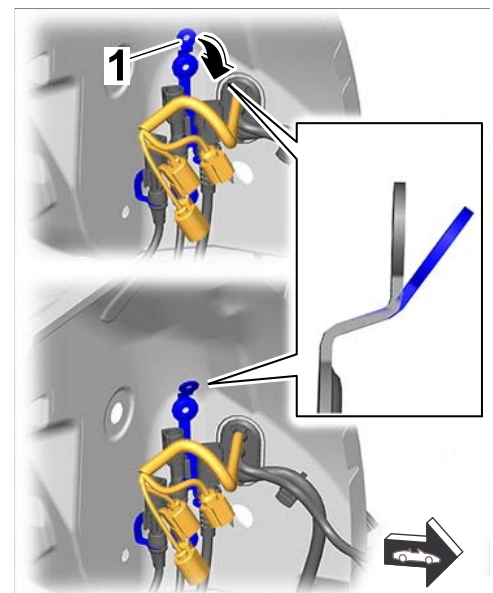

*Bending bracket*

- 3 Affix anti-chafing element on wire harness for rear axle steering.
  - 3.1 Position anti-chafing element ⇒ *Affixing anti-chafing element -1-* on the wire harness. To do this, align the anti-chafing element, starting at the rubber sleeve.
  - 3.2 Pull protective paper off the adhesive strip on the anti-chafing element and affix anti-chafing element so that it is wrapped closely around the wire harness.
  - 3.3 Wrap textile insulating tape ⇒ *Affixing anti-chafing element -2-* at least three times around both ends of the anti-chafing element.

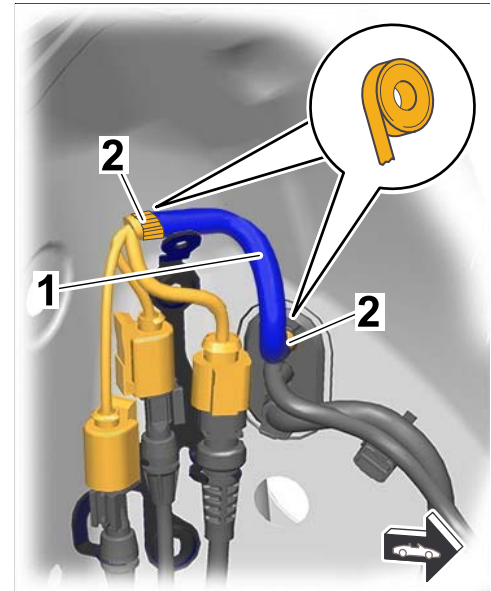

Affixing anti-chafing element

- 4 Secure wire harness for rear axle steering.
  - 4.1 Clip in new tie-wrap holder on the inside of the bracket.
  - 4.2 Insert wire harness into the open tie-wrap on the tie-wrap holder ⇒ *Securing wire harness -arrow A-*.
  - 4.3 Press plug connections for wire harness into the bracket ⇒ *Securing wire harness -arrows B-*. Make sure it is routed without tension, avoiding chafing points.
  - 4.4 Close the tie-wrap and secure the wire harness at the tie-wrap holder. Then cut off the extra length of tie-wrap.
- 5 Repeat steps 1 to 4.4 on the other side of the vehicle.

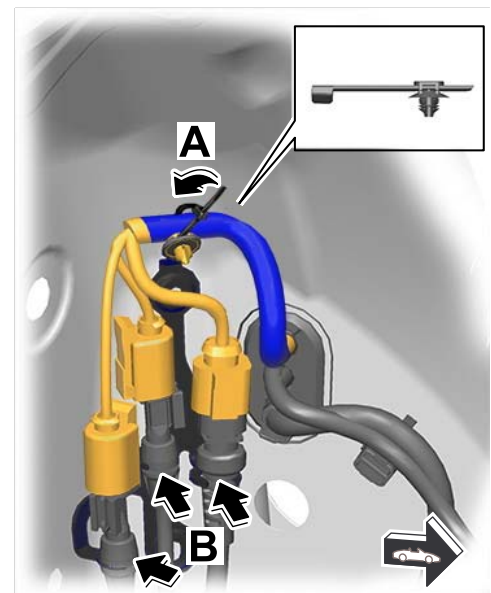

Securing wire harness

#### Concluding work

- 1 Install rear wheel housing liner ⇒ *Workshop Manual '536919 Removing and installing rear wheel housing liner'*.
- 2 Install wheel with central bolt ⇒ *Workshop Manual '440519 Removing and installing wheel with central bolt'*.



Invoicing: **Invoicing**

The work involved is invoiced under the labor operation:

APOS	Labour operation	I No.
97655000	Reworking wire harness	

For invoicing and documentation using PQIS, enter the following coding:

Location (FES5)	97650	Wire harness
Damage type (SA4)	9735	Repair in accordance with PAG instructions

**Reworking side panel (wheel arch)**

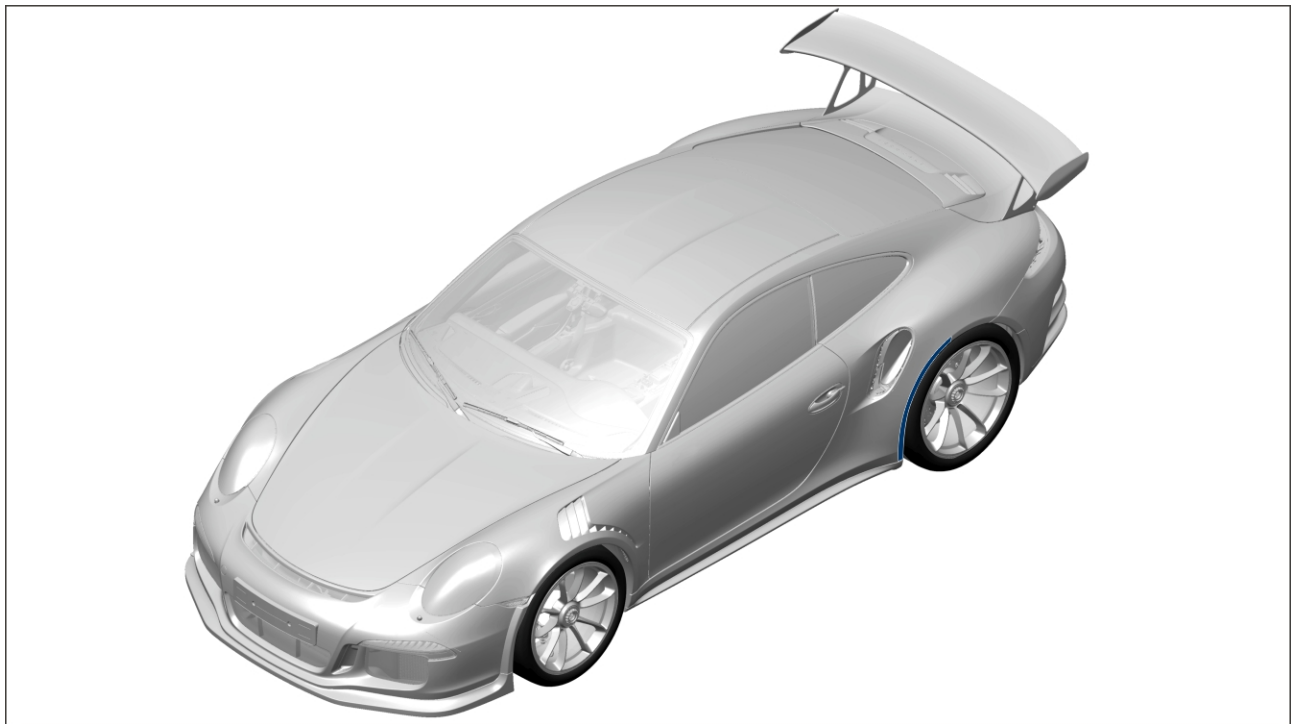

*Installation position of wheel arch*

**Information**

The use of a reforming and flaring tool ("flaring roller") that is usually used for body repairs (commercially available tool) is recommended for flaring the wheel arch.

In order to fit the tool on the contact surface of the brake disc, the tool must have a mounting with a pitch circle diameter of 130 mm.

Some adapter plates for a pitch circle diameter of 130 mm are available individually as accessories for the reforming and flaring tool.

- Tools:
- Commercially available reforming and flaring tool suitable for a pitch circle with **Diameter 130 mm**.
  - Heat gun, e.g. **V.A.G. 1416 - Hot-air blower**
  - Temperature gauge, e.g. **VAS 6886 - Temperature gauge**

Parts Info:	Part No.	Designation	Qty.
	991 341 905 80	⇒ Mounting parts (set) comprising: – Driving pin (5 ea.) – Cheese head bolt (5 ea.)	2 ea.
	999 067 053 09	⇒ Cheese head bolt M12 x 1.5 x 85 – For securing brake caliper to wheel carrier	4 ea.

Work  
Procedure:

**Preparatory work**

- 1 Remove wheel with central bolt ⇒ *Workshop Manual '440519 Removing and installing wheel with central bolt'*.
- 2 Remove rear wheel housing liner ⇒ *Workshop Manual '536919 Removing and installing rear wheel housing liner'*.
- 3 Loosen the brake caliper ⇒ *Workshop Manual '465019 Removing and installing front brake disc'*.
- 4 Loosen rear transmitter (trigger) for Tire Pressure Monitoring (TPM) ⇒ *Workshop Manual '443819 Removing and installing TPM antenna'*.

**Reworking side panel (wheel arch)****Information**

The following work is described for the right-hand side of the vehicle as an example.

The steps are identical for both sides of the vehicle and must be carried out at the left and right.

- 1 Clean the wheel arch.

- 2 Remove fastening screws ⇒ *Brake disc mounting on wheels with central bolts (shown as an example/figure shows front axle) -1-* and wheel driver pins ⇒ *Brake disc mounting on wheels with central bolts (shown as an example/figure shows front axle) -2-*.

- 3 Fit flaring tool on the contact surface of the brake disc using the fastening screws for the driving pins which you removed earlier.



**Information**

When positioning the flaring tool, make sure that the contact surfaces are lying flat on top of each other and that the flaring tool is centered.

- 3.1 Position flaring tool ⇒ *Fitting flaring tool-1-* on the contact surface of the brake disc.

- 3.2 Screw in and tighten fastening screws with washers fitted ⇒ *Fitting flaring tool-2-*.

- 4 Flare the wheel arch.

- 4.1 Heat the rear side panel in the wheel arch area before and during flaring using a heat gun, e.g. **WE1119 - Hot-air blower, Leister Electron/V.A.G. 1416**.



**Information**

Check the temperature at the wheel arch using **VAS 6886 - temperature gauge**. The temperature must not exceed 140° F (60° C) + 50° F (10° C).

Get another person to help you to heat the flange area with the heat gun and monitor the temperature at the same time.

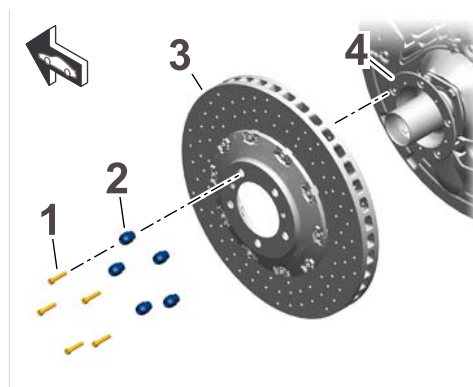

*Brake disc mounting on wheels with central bolts (shown as an example/figure shows front axle)*

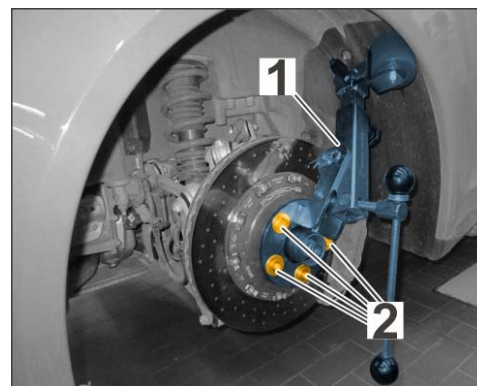

*Fitting flaring tool*

**Information**

When flaring the wheel arch, move the roller of the flaring tool further forward gradually, starting from the existing flanged edge and re-roll the flange area several times.

- 4.2 Slowly move the flaring tool along the wheel arch and carefully bend up the wheel arch edge  $\Rightarrow$  *Flaring the wheel arch*.

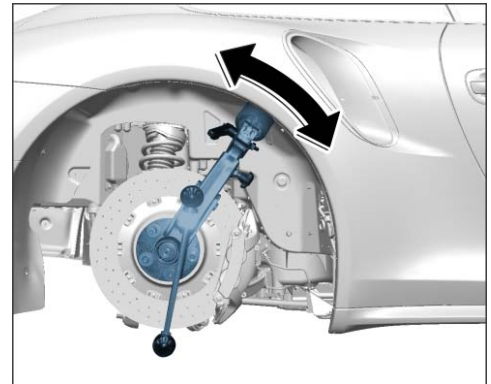

*Flaring the wheel arch*

- 5 Flare the wheel arch initially up to a distance of **29 cm** from the door sill  $\Rightarrow$  *Flange area -dimension X-*.

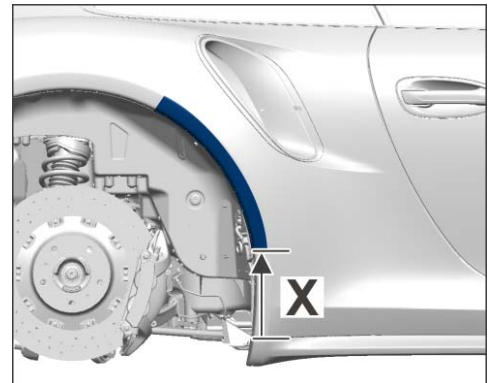

*Flange area*

- 6 Then continue flaring downwards up to a distance of **24 cm** from the door sill ⇒ *Flaring dimensions -dimension Y-* (⇒ *Flaring dimensions -arrow-*).

**dimension X** – Flaring up to a distance of **29 cm** from the door sill

**dimension Y** – Flaring run-out up to a distance of **24 cm** from the door sill

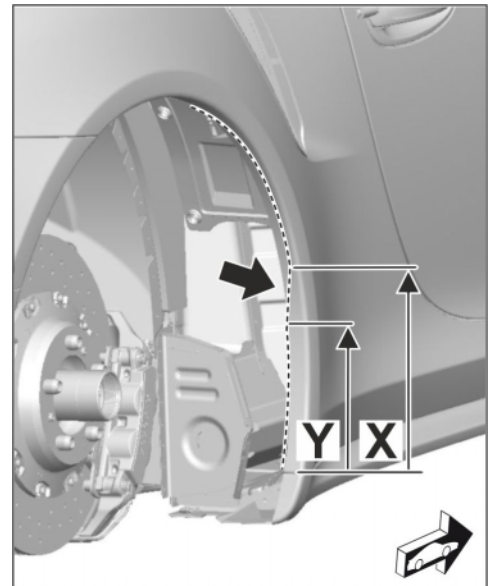

*Flaring dimensions*

- 7 Remove flaring tool ⇒ *Removing flaring tool-1-*.

7.1 Unscrew fastening screws ⇒ *Removing flaring tool-2-*.

7.2 Remove washers.

- 8 Install new wheel driver pins ⇒ *Brake disc mounting on wheels with central bolts-2-* with new fastening screws ⇒ *Brake disc mounting on wheels with central bolts-1-*.

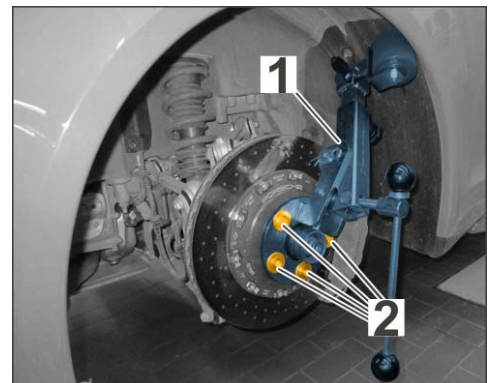

*Removing flaring tool*

Use set of mounting parts according to Porsche Electronic Parts Catalog (PET). Set contains new wheel driver pins and fastening screws.

**Pay particular attention to the following when fitting the wheel driver pins:**

- All contact surfaces must be clean and free of grease
- Tightening torque - 911 GT3 RS: **Tightening torque 31 Nm (23ftlb.)**

**Concluding work**

- 1 Secure rear transmitter (trigger) for Tire Pressure Monitoring (TPM) ⇒ *Workshop Manual '443819 Removing and installing TPM antenna'*.
- 2 Secure the brake caliper ⇒ *Workshop Manual '465019 Removing and installing front brake disc'*.
- 3 Install rear wheel housing liner ⇒ *Workshop Manual '536919 Removing and installing rear wheel housing liner'*.
- 4 Install wheel with central bolt ⇒ *Workshop Manual '440519 Removing and installing wheel with central bolt'*.
- 5 Check flared area on the wheel arch.  
If cracks have formed in the paintwork as a result of flaring, spot-paint the affected area.

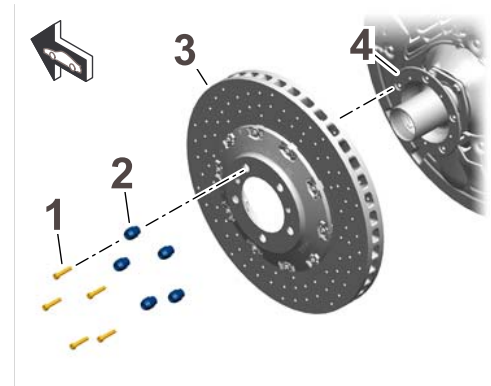

*Brake disc mounting on wheels with central bolts*

Invoicing: **Invoicing**

The work involved is invoiced under the labor operation:

APOS	Labour operation	I No.
53555030	Reworking rear side panels	
51017112	Preparing body for painting	
53557980	Painting rear side panels	

For invoicing and documentation using PQIS, enter the following coding:

Location (FES5)	53550	Rear side panel
Damage type (SA4)	9735	Repair in accordance with PAG instructions

**Important Notice:** Technical Bulletins issued by Porsche Cars North America, Inc. are intended only for use by professional automotive technicians who have attended Porsche service training courses. They are written to inform those technicians of conditions that may occur on some Porsche vehicles, or to provide information that could assist in the proper servicing of a vehicle. Porsche special tools may be necessary in order to perform certain operations identified in these bulletins. Use of tools and procedures other than those Porsche recommends in these bulletins may be detrimental to the safe operation of your vehicle, and may endanger the people working on it. Properly trained Porsche technicians have the equipment, tools, safety instructions, and know-how to do the job properly and safely. If a particular condition is described, do not assume that the bulletin applies to your vehicle, or that your vehicle will have that condition. See your authorized Porsche Dealer for the latest information about whether a particular technical bulletin applies to your vehicle. Part numbers listed in these bulletins are for reference only. Always check with your authorized Porsche dealer to verify the current and correct part numbers. The work procedures updated electronically in the Porsche PIWIS diagnostic and testing device take precedence and, in the event of a discrepancy, the work procedures in the PIWIS Tester are the ones that must be followed.

© Porsche Cars North America, Inc.

Dealership	Service Manager	Shop Foreman	Service Technician
Distribution	Asst. Manager	Warranty Admin.	Service Technician
Routing			

Dr. Ing. h.c. F. Porsche AG is the owner of numerous trademarks, both registered and unregistered, including without limitation the Porsche Crest®, Porsche®, Boxster®, Carrera®, Cayenne®, Cayman®, Macan®, Panamera®, Speedster®, Spyder®, 918 Spyder®, Tiptronic®, VarioCam®, PCM®, PDK®, 911®, RS®, 4S®, FOUR, UNCOMPROMISED®, and the model numbers and the distinctive shapes of the Porsche automobiles such as, the federally registered 911 and Boxster automobiles. The third party trademarks contained herein are the properties of their respective owners. Porsche Cars North America, Inc. believes the specifications to be correct at the time of printing. Specifications, performance standards, standard equipment, options, and other elements shown are subject to change without notice. Some options may be unavailable when a car is built. Some vehicles may be shown with non-U.S. equipment. The information contained herein is for internal authorized Porsche dealer use only and cannot be copied or distributed. Porsche recommends seat belt usage and observance of traffic laws at all times.

Printed in the USA