

**Sports Exhaust System (I-no. XLF)**

Revision: This bulletin replaces bulletin Group 2, #33/12, dated October 2, 2015.

Model Year: **As of 2013**

Concern: **Retrofitting**

Restrictions: • **ONLY** together with sports tailpipe (I-no. XLS).

Engine Types: MA122 = 2.7 l – Boxster  
 MA123 = 3.4 l – Boxster S

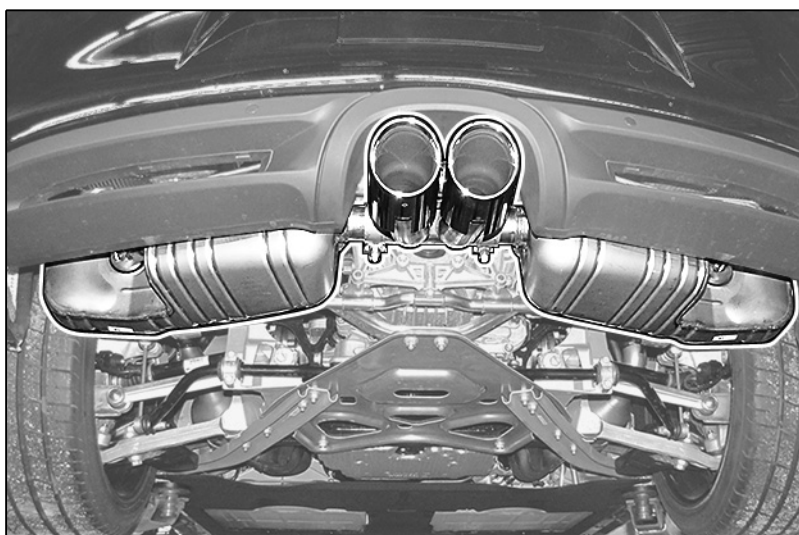

Notes: The sports exhaust system is activated and deactivated using the new switch console with the additional "Twin tailpipe" button. The sports exhaust system is also activated by pressing the "Sport" and "Sport Plus" buttons. The sports exhaust system can be switched off separately in these modes using the "Twin tailpipe" button.

The switch console (combined switch) is a repair kit and must also be ordered. The repair kit contains the main body, the required buttons and the trims. The new switch console is assembled in accordance with the new vehicle equipment.

Engine power and exhaust behaviour of the vehicle are not affected. The sports exhaust system is also available as a factory installed option for new vehicles by requesting optional equipment "XLF".

Parts Info: **981.044.200.00** ⇒ Sports exhaust system WITH sports tailpipe for Boxster, set  
**981.044.200.04** ⇒ Sports exhaust system WITH sports tailpipe for Boxster S, set  
**981.044.200.01** ⇒ Sports exhaust system WITHOUT sports tailpipe, set

Also order the following:  
**991.613.961.03.DML** Combined switch (switch console)

Parts List:

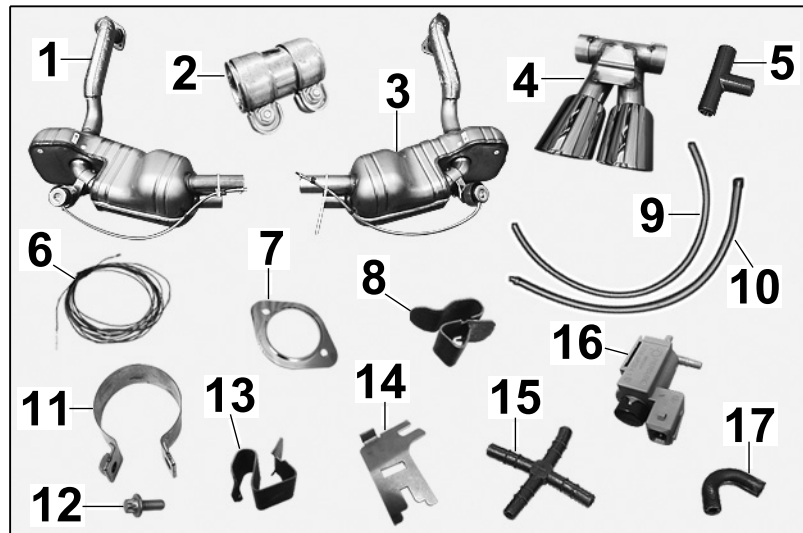

Figure 2

981.111.921.02	1 x	Rear muffler, left ⇒ Figure 2-1-
981.111.280.00	1 x	Clamp ⇒ Figure 2-2-
981.111.922.02	1 x	Rear muffler, right ⇒ Figure 2-3-
981.111.961.00 <sup>1</sup>	1 x	Sports tailpipe ⇒ Figure 2-4-
981.111.961.01 <sup>2</sup>	1 x	Sports tailpipe (not shown)
06E.133.794	1 x	T-piece ⇒ Figure 2-5-
981.612.905.00	1 x	Wire harness ⇒ Figure 2-6-
981.111.113.00	2 x	Seal ⇒ Figure 2-7-
999.651.360.01	4 x	Fixing clip ⇒ Figure 2-8-
981.111.049.00	1 x	590-mm steel flexi-pipe ⇒ Figure 2-9-
900.918.005.40	1 x	Tekalan line, 5.0 x 1.0 x 1,000 mm ⇒ Figure 2-10-
981.111.281.01	2 x	Clamp ⇒ Figure 2-11-
900.385.001.02	2 x	Torx screw, M8 x 20 ⇒ Figure 2-12-
3D0.971.939.B	1 x	Fixing clip (transmission) ⇒ Figure 2-13-
981.111.989.00	1 x	Change-over valve holder ⇒ Figure 2-14-
928.573.729.05	1 x	Distributing piece, 4-way ⇒ Figure 2-15-

7PP.906.270	1 x	Change-over valve ⇒ <i>Figure 2-16-</i>
928.574.717.05	2 x	Protective tube ⇒ <i>Figure 2-17-</i>
900.910.003.03	4 x	Hexagon nut, M8 (not shown)
999.141.047.01	4 x	Torx screw, M10 x 28 (for securing seat, not shown)
928.573.727.05	1 x	Distributing piece, 3-way (Y-piece, not shown)
N 020.904.4	15 x	Tie-wrap (not shown)
999.507.206.40	2 x	Combination holder (not shown)

1 ONLY contained in set 981.044.200.00.

2 ONLY contained in set 981.044.200.04.

Materials:	000.043.004.82	1 x	Optimol-HT mounting paste
	— — —		Rust solvent, commercially available, e.g. WD40

Notes: **Identifying features when installed:**  
A part number and the Porsche logo are shown on the rear mufflers and tailpipe.

Tools: **9818 - PIWIS Tester II**  
**T10118 - Assembly tool**  
**P300 - Socket-wrench insert**

- Work Procedure: 1 Preparatory work.
- 1.1 Move convertible top to service position. ⇒ *Workshop Manual '6101IN Convertible-top service position'*
  - 1.2 Remove engine compartment lid. ⇒ *Workshop Manual '557819 Removing and installing engine compartment lid'*
  - 1.3 Remove inner door sill trim on the left. ⇒ *Workshop Manual '680519 Removing and installing inner door sill trim'*
  - 1.4 Remove left front seat. ⇒ *Workshop Manual '720119 Removing and installing front seat'*
  - 1.5 Remove trim panel for rear-wall sound absorber. ⇒ *Workshop Manual '703119 Removing and installing trim panel for rear wall'*
  - 1.6 Loosen seat belt mount in the B-pillar sill area.

- 1.6.1 Open the cap ⇒ *Figure 3-1-*.
- 1.6.2 Unscrew cheese head bolt ⇒ *Figure 3-2-* and remove seat belt mount ⇒ *Figure 3-3-* and spacer sleeve ⇒ *Figure 3-4-*.
- 1.7 Remove side trim panel at the left. ⇒ *Workshop Manual '707519 Removing and installing side trim panel'*
- 1.8 Remove and install rear luggage compartment trim. ⇒ *Workshop Manual '700619 Removing and installing rear luggage compartment trim panel'*
- 1.9 Loosen parking brake control unit ⇒ *Figure 4-1-*.
- 1.9.1 Screw off fastening nuts ⇒ *Figure 4-2-*.
- 1.9.2 Pull parking brake control unit off the studs.
- 1.10 Remove moulded part ⇒ *Figure 5-1-*.
- 1.11 Loosen relay carrier in luggage compartment at the right.

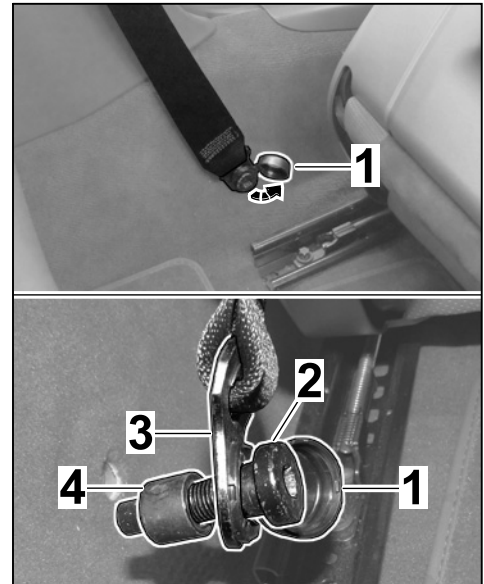

Figure 3

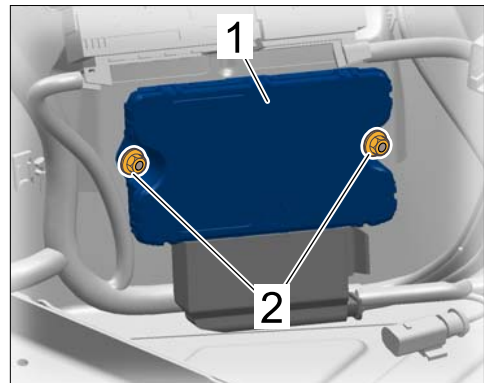

Figure 4

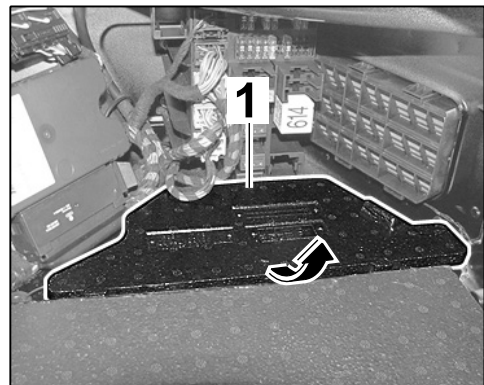

Figure 5

- 1.11.1 Release electric plug connection ⇒ *Figure 6 -arrow a-* and pull it off ⇒ *Figure 6 -arrow b-*.

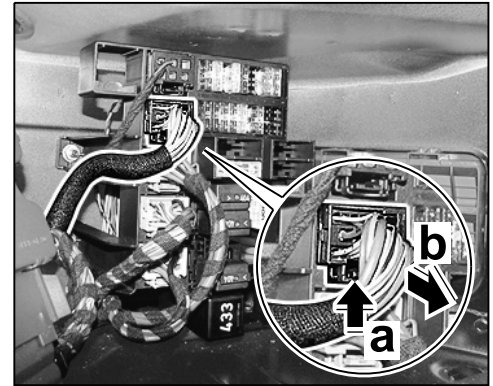

Figure 6

- 1.11.2 Unscrew fastening nuts ⇒ *Figure 7 -2-* and pull relay carrier for luggage compartment at the right ⇒ *Figure 7-1-* off the studs and set it down.

2 Install electric wire harness.

- 2.1 Secure electric wire harness to the auxiliary line.

- 2.2 Route electric wire harness as follows:  
Passenger compartment → along standard wire harness in passenger compartment at the left → cable duct → convertible-top compartment → relay carrier in luggage compartment at the right

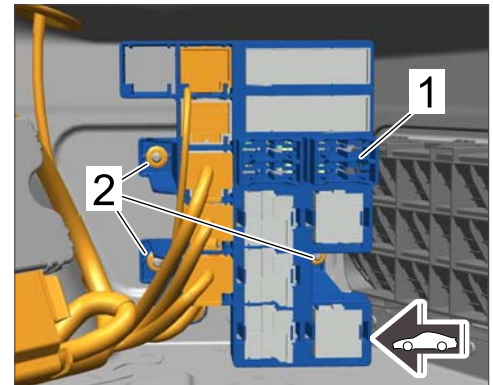

Figure 7

- 2.2.1 Route electric wire harness ⇒ *Figure 8-1-* from the rear-end electronics control unit position ⇒ *Figure 8-2-*, along wire harness in passenger compartment at the left to the cable duct ⇒ *Figure 8-3-*.

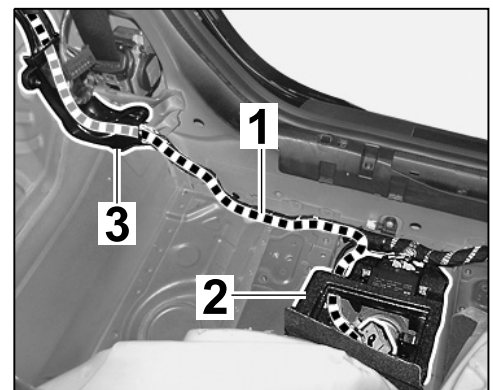

Figure 8

- 2.2.2 Route electric wire harness ⇒  
*Figure 9-1-* through the body ⇒  
*Figure 9-2-* to the convertible-top  
compartment. Lift up insulating mat  
⇒ *Figure 9-3-* to do this.

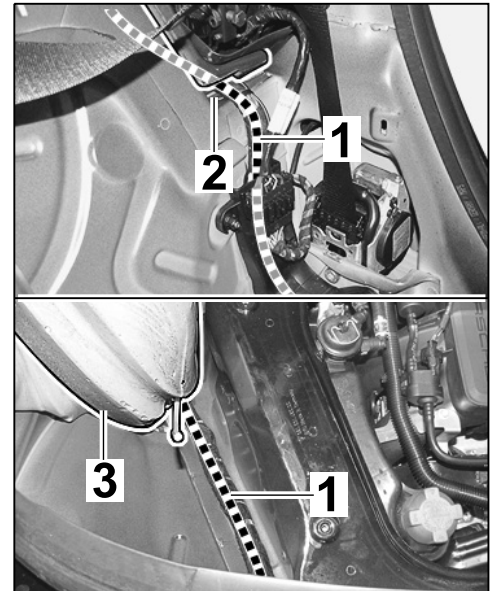

Figure 9

- 2.2.3 Route electric wire harness ⇒  
*Figure 10-1-* along the standard  
wire harness to the relay carrier in  
the luggage compartment at the  
right.

- 2 – Digital engine electronics (DME) control unit
- 3 – Relay carrier in luggage compartment at the right
- 4 – Parking brake control unit

- 2.3 Use tie-wraps to secure electric wire harness to existing lines or components without tension and so that no chafing occurs.

- 2.4 Connect electric wire harness to the rear-end electronics control unit.

- 2.4.1 Shorten BK/YE line and crimp together using a socket contact.

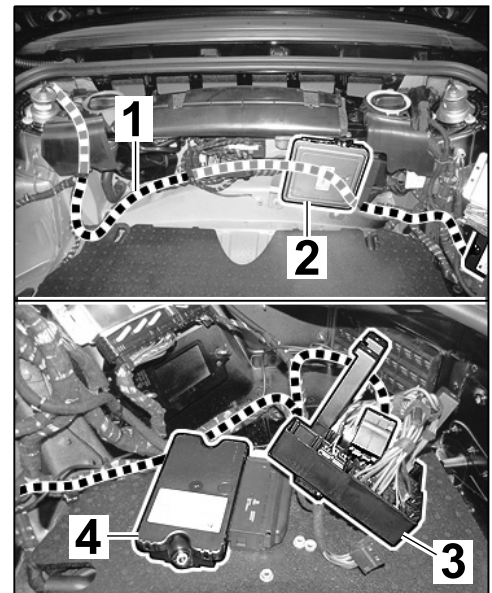

Figure 10

- 2.4.2 Fold carpet ⇒ *Figure 11 -arrow-* aside.
- 2.4.3 Remove rear-end electronics control unit ⇒ *Figure 11-1-* from the foam holder ⇒ *Figure 11-2-* and turn it until the plug connections are accessible.

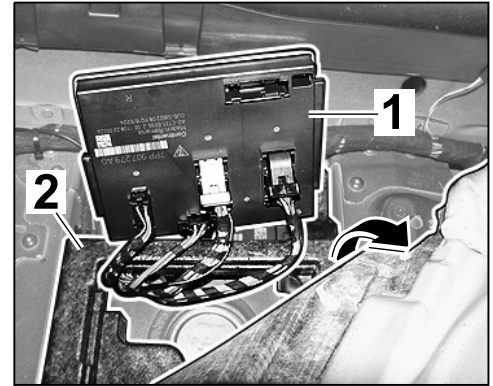

Figure 11

- 2.4.4 Release electric plug connection ⇒ *Figure 12-2-* (blue) by pressing the locking mechanism ⇒ *Figure 12-arrow-* and swivel the clip ⇒ *Figure 12-1-* upwards ⇒ *Figure 12-arrow-*.

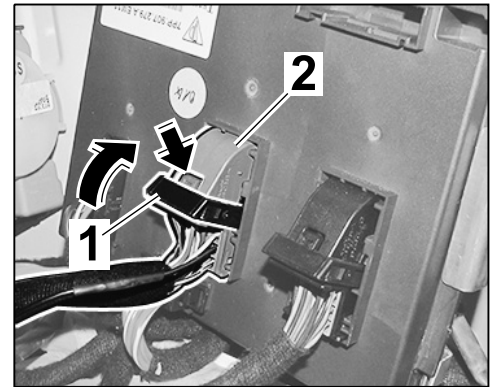

Figure 12

- 2.4.5 Press down the locking mechanism ⇒ *Figure 13-arrow-* and slide the grey plug socket ⇒ *Figure 13-1-* out of the plug carrier ⇒ *Figure 13-2-*.

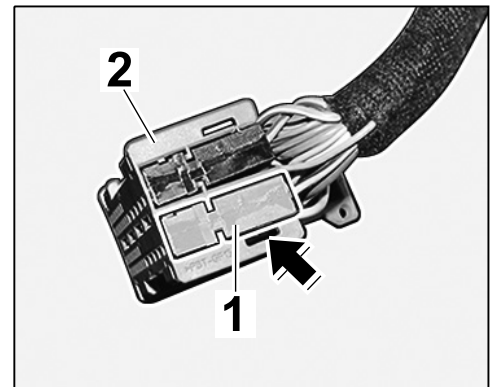

Figure 13

**Information**

Ensure socket contact is seated securely.

- 2.4.6 Insert socket contact ⇒ *Figure 14 -1-* into chamber A2 of the grey plug socket ⇒ *Figure 14-2-*.

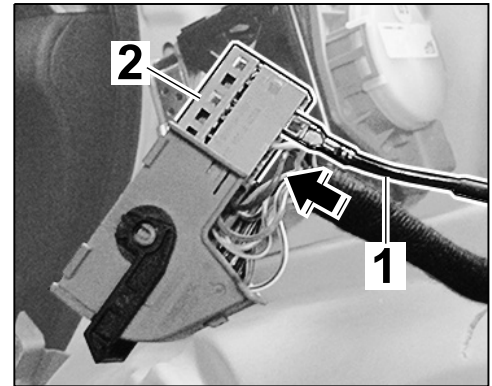

Figure 14

- 2.4.7 Slide grey plug socket ⇒ *Figure 15 -1-* into the plug carrier ⇒ *Figure 15-2-* until the locking mechanism ⇒ *Figure 15 -arrow-* engages.

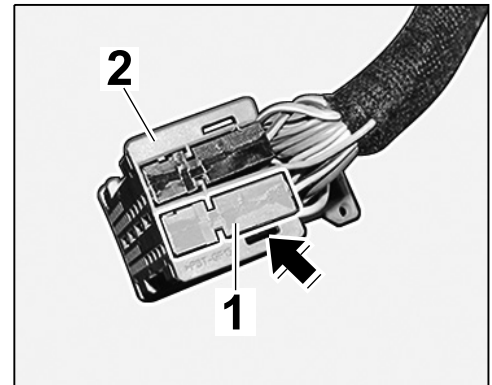

Figure 15

- 2.4.8 Connect electric plug connection ⇒ *Figure 16-2-* and swivel the clip ⇒ *Figure 16-1-* downwards.
- 2.4.9 Insert rear-end electronics control unit into the foam holder.
- 2.4.10 Fold back the carpet.
- 2.5 Connect BK/YE line to the black 17-pin connector socket (engine pre-wiring X31).

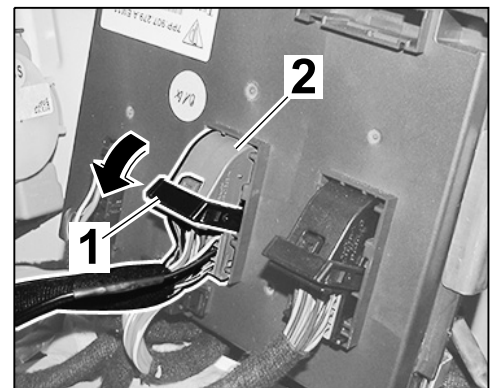
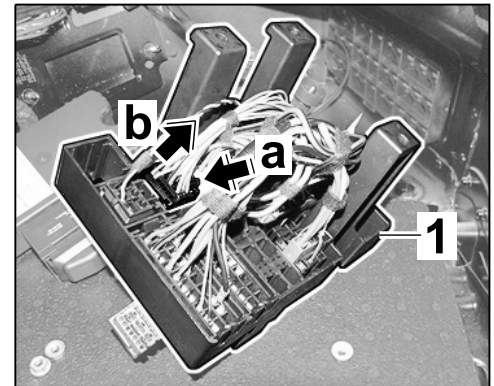

Figure 16



- 2.5.1 Release pin connector socket ⇒ *Figure 17* -**arrow a**- and pull it out of the relay carrier in the luggage compartment at the right ⇒ *Figure 17-1*- (⇒ *Figure 17* -**arrow b**-).



*Figure 17*

- 2.5.2 Release secondary lock on pin connector socket ⇒ *Figure 18* -**arrow**-.

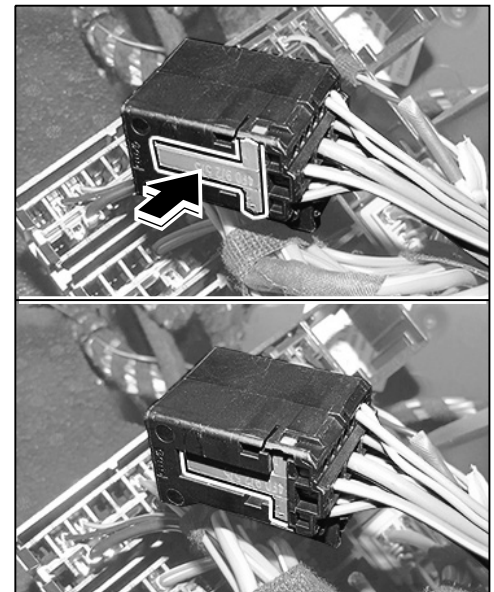

*Figure 18*



Information

Ensure socket contact is seated securely.

2.5.3 Insert pin contact ⇒ *Figure 19-1*- into chamber 5 of the pin connector socket ⇒ *Figure 19-2*-.

2.5.4 Lock secondary lock.

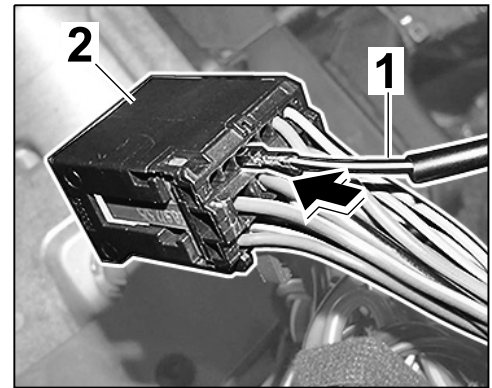

Figure 19

2.5.5 Insert pin connector socket ⇒ *Figure 20-1*- into the relay carrier in the luggage compartment at the right ⇒ *Figure 20-2*- until the locking lug locks with an audible click.

3 Concluding work for installing wire harness.

3.1 Install relay carrier in luggage compartment at the right.

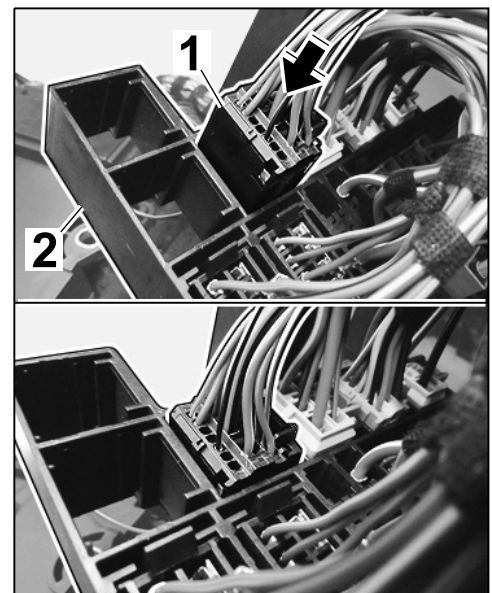

Figure 20

- 3.1.1 Position relay carrier in luggage compartment at the right ⇒ *Figure 21-1-* on the studs. Tighten fastening nuts ⇒ *Figure 21-2-*. **Tightening torque 9.7 Nm (7.5 ftlb.)**

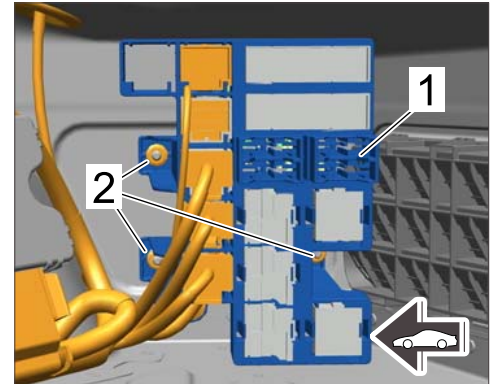

Figure 21

- 3.1.2 Connect electric plug connection.

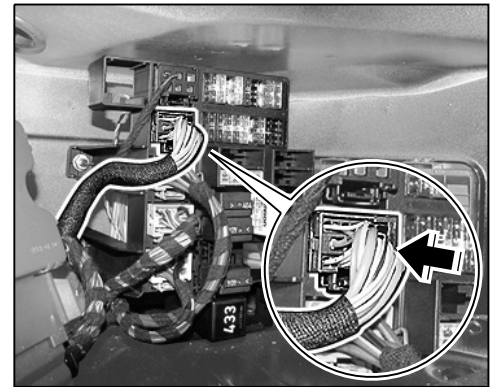

Figure 22

- 3.2 Secure parking brake control unit ⇒ *Figure 23-1-*.
  - 3.2.1 Position parking brake control unit on the studs.
  - 3.2.2 Tighten fastening nuts ⇒ *Figure 23-2-*.

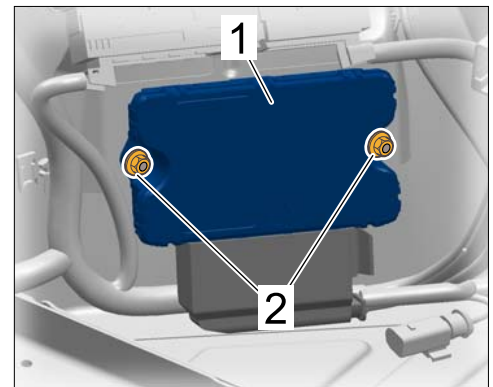

Figure 23

3.3 Fit moulded part ⇒ *Figure 24 -1-*.

4 Remove rear mufflers. ⇒ *Workshop Manual '263319 Removing and installing rear silencer'*



#### Information

Insert vacuum line at least 10 mm into the steel flexi-pipe.

5 Assemble vacuum lines.

5.1 Connect vacuum lines as shown.

#### 5.1.1 Vehicles with manual transmission

- 1 – T-piece
- 2 – 590-mm steel flexi-pipe
- 3 – 750-mm Tekalan line
- 4 – Protective tube
- 5 – Change-over valve
- 6 – 170-mm vacuum line
- 7 – Y-piece

Cut 750-mm ⇒ *Figure 25 -3-* and 170-mm lengths ⇒ *Figure 25 -6-* off the supplied Tekalan line.



#### Information

Insert vacuum line at least 10 mm into the steel flexi-pipe.

Fit 590-mm steel flexi-pipe ⇒ *Figure 25 -2-* and 750-mm Tekalan line ⇒ *Figure 25 -3-* together.

Fit 590-mm steel flexi-pipe ⇒ *Figure 25 -2-* into the T-piece ⇒ *Figure 25 -1-*.

Insert 750-mm Tekalan line and 170-mm Tekalan line at least 10 mm into the protective tubes ⇒ *Figure 25 -4-*.

Fit 170-mm Tekalan line ⇒ *Figure 25 -6-* into the Y-piece.

Fit protective tubes on change-over valve ⇒ *Figure 25 -5-*.

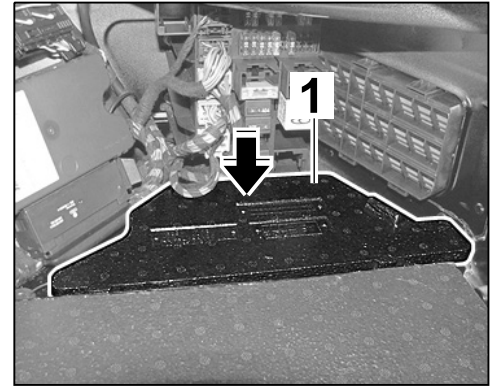

Figure 24

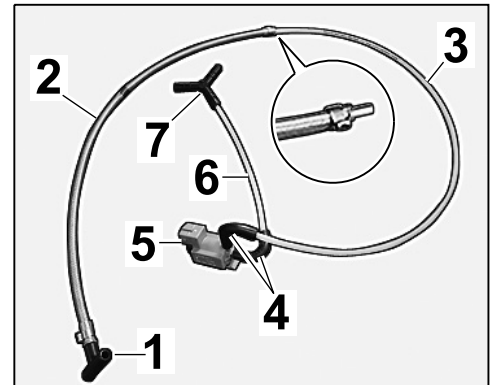

Figure 25

5.1.2 **Vehicles with Porsche Doppelkupplung (PDK)**

- 1 - T-piece
- 2 - 590-mm steel flexi-pipe
- 3 - 595-mm Tekalan line
- 4 - Protective tube
- 5 - Change-over valve
- 6 - 225-mm Tekalan line
- 7 - Distributing piece, 4-way

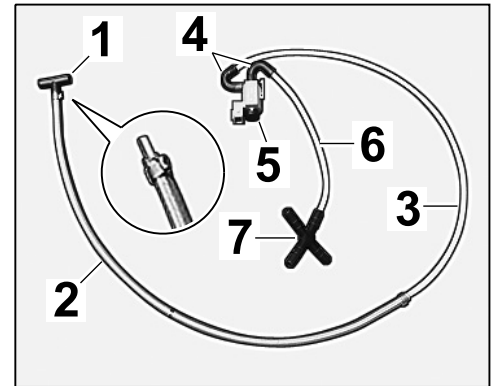

Figure 26

Cut 595-mm ⇒ *Figure 26-3-* and 225-mm lengths ⇒ *Figure 26-6-* off the supplied Tekalan line.



**Information**

Insert vacuum line at least 10 mm into the steel flexi-pipe.

Fit 590-mm steel flexi-pipe ⇒ *Figure 26-2-* and 595-mm Tekalan line ⇒ *Figure 26-3-* together.

Fit 590-mm steel flexi-pipe ⇒ *Figure 26-2-* into the T-piece ⇒ *Figure 26-1-*.

Insert 595-mm Tekalan line and 255-mm Tekalan line at least 10 mm into the protective tubes ⇒ *Figure 26-4-*.

Fit 225-mm Tekalan line into the 4-way distributing piece ⇒ *Figure 26-7-*.

Fit protective tubes on change-over valve ⇒ *Figure 26-5-*.

5.2 Lock single-lug clip ⇒ *Figure 27-1-*.

Fit fixing clip ⇒ *Figure 27-2-* at the marked position (black) on the steel flexi-pipe.

6 Install vacuum lines.

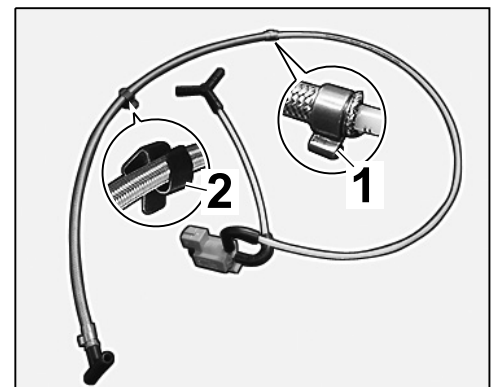

Figure 27

**Information**

The wire harness for the change-over valve is incorporated as standard in the engine wire harness and is secured to the cable duct with wrapping tape.

- 6.1 Expose wire harness for change-over valve ⇒ *Figure 28 -arrow-*.

- 6.2 Install change-over valve holder.

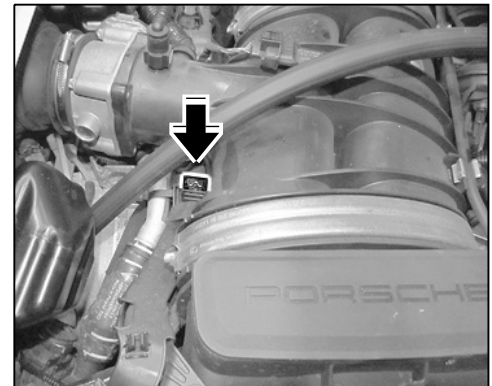

Figure 28

- 6.2.1 Loosen Torx screw ⇒ *Figure 29-1-* on the intake bridge.

- 6.2.2 Slide change-over valve holder ⇒ *Figure 29-2-* under the Torx screw and tighten Torx screw.

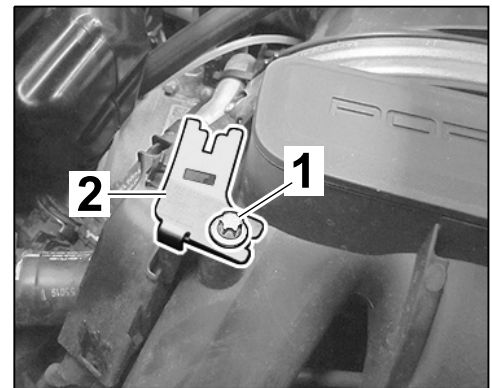

Figure 29

- 6.3 Slide change-over valve ⇒ *Figure 30-1-* onto the change-over valve holder. Route the longer vacuum line ⇒ *Figure 30-3-* along the shift cable ⇒ *Figure 30-4-* and down to the transmission ⇒ *Figure 30-arrow b-*.

Pull off dummy plug on change-over valve connector.

Connect plug connection ⇒ *Figure 30-arrow a-*.

- 6.4 **Only** for vehicles with PDK:  
Connect vacuum lines for change-over valve.

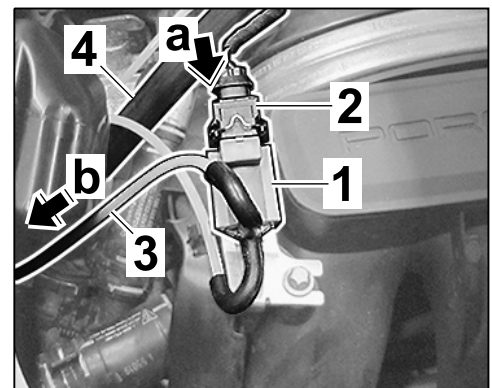

Figure 30

6.4.1 Pull Y-piece ⇒ *Figure 31-1*- off the standard change-over valve ⇒ *Figure 31-2*-.

5 – Throttle valve

6.4.2 Pull Tekalan line (vacuum line on engine side) ⇒ *Figure 31-4*- and Tekalan line (vacuum line on transmission side) ⇒ *Figure 31-3*- out of the Y-piece ⇒ *Figure 31-1*-.

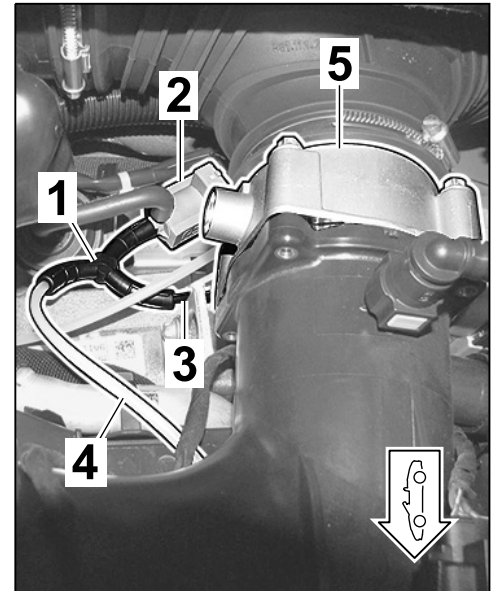

Figure 31

6.4.3 Insert Tekalan line (vacuum line on engine side) ⇒ *Figure 32-4*-, Tekalan line (vacuum line on transmission side) ⇒ *Figure 32-3*- and Tekalan line (vacuum line for change-over valve for sports exhaust system) ⇒ *Figure 32-5*- at least 10 mm into the 4-way distributing piece.

6.4.4 Fit 4-way distributing piece ⇒ *Figure 32-1*- on the standard change-over valve ⇒ *Figure 32-2*-.

6.5 **Only** for vehicles with manual transmission: Connect vacuum lines for change-over valve.

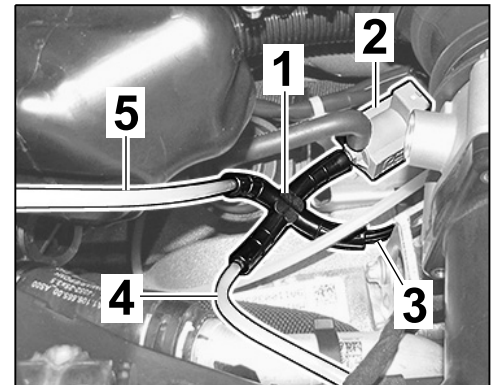

Figure 32

- 6.5.1 Pull Tekalan line (vacuum line on engine side) ⇒ *Figure 33-1-* and Tekalan line (vacuum line on transmission side) ⇒ *Figure 33-2-* out of the connecting piece ⇒ *Figure 33-3-*.

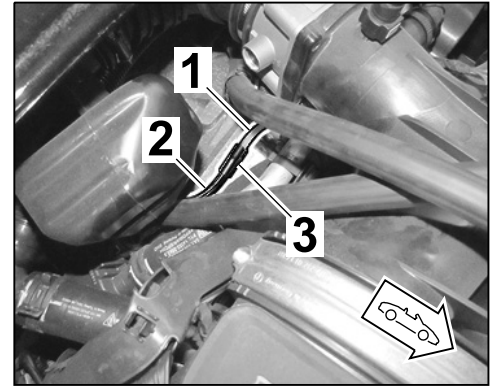

Figure 33

- 6.5.2 Insert Tekalan line (vacuum line on engine side) ⇒ *Figure 34-2-*, Tekalan line (vacuum line on transmission side) ⇒ *Figure 34-3-* and Tekalan line (vacuum line for change-over valve for sports exhaust system) ⇒ *Figure 34-4-* at least 10 mm into the Y-piece ⇒ *Figure 34-1-*.

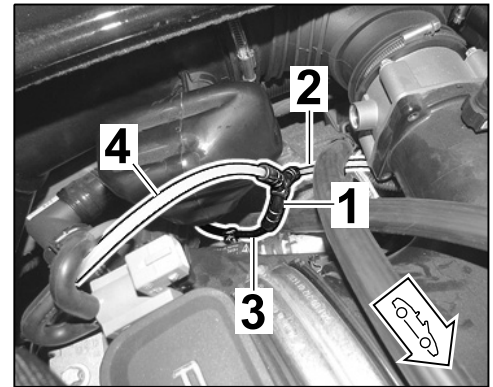

Figure 34

**Information**

The vacuum line is routed correctly if the T-piece is touching the rear support **rear arrow**.

- 6.6 Fit fixing clip ⇒ *Figure 35-arrow-* in the pocket before the third cross strut on the transmission.
- 7 Install new rear mufflers. ⇒ *Workshop Manual '263319 Removing and installing rear silencer'*
- 8 Secure vacuum lines in the rear support area.

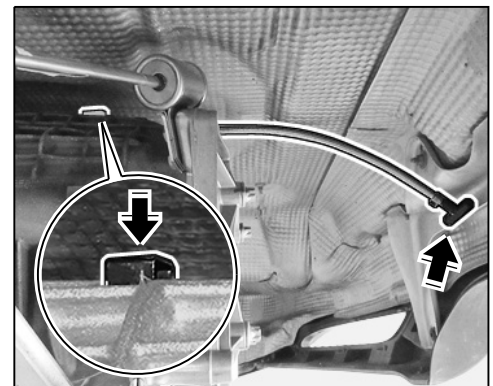

Figure 35



8.1 Fit four fixing clips ⇒ *Figure 36 -1-* on rear support ⇒ *Figure 36 -2-*. Check spacing!

- a - 155 mm
- b - 48 mm

8.2 Join steel flexi-pipes from the rear mufflers and T-piece.

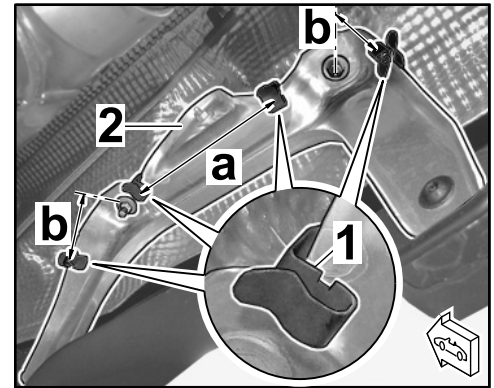

Figure 36



### Information

Steel flexi-pipe follows the inner contour of the rear support ⇒ *Figure 37 -arrows-*.

Fit steel flexi-pipe ⇒ *Figure 37-2-* into the clips ⇒ *Figure 37-1-*.

- ✓ - Position of steel flexi-pipe is OK
- X - Position of steel flexi-pipe is not OK

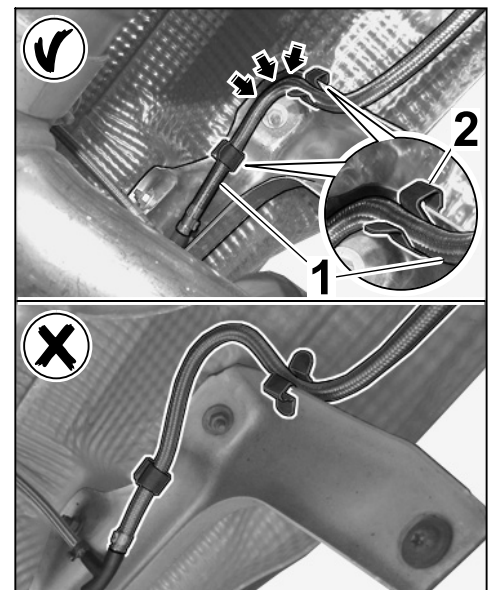

Figure 37

**Information**

The steel flexi-pipe should only be barely visible in the air outlet area.

- 8.3 Fit steel flexi-pipe in the fixing clips and check that the steel flexi-pipe is not hanging down from the rear apron in the air outlet area.

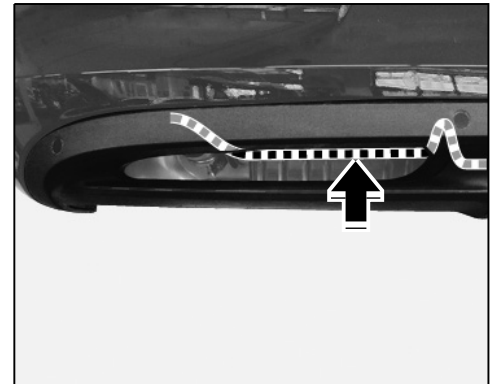

Figure 38

- 9 **Only** for vehicles with manual transmission:  
Fit the holders ⇒ *Figure 39-1-* on the coolant hoses.  
Clip 750-mm Tekalan line ⇒ *Figure 39-2-* into the holder.

- 10 Concluding work.

- 10.1 Install rear luggage compartment trim panel.  
⇒ *Workshop Manual '700619 Removing and installing rear luggage compartment trim panel'*
- 10.2 Install engine compartment lid. ⇒ *Workshop Manual '557819 Removing and installing engine compartment lid'*
- 10.3 Install trim panel for rear-wall sound absorber.  
⇒ *Workshop Manual '703119 Removing and installing trim panel for rear wall'*
- 10.4 Install side trim panel at the left. ⇒ *Workshop Manual '707519 Removing and installing side trim panel'*
- 10.5 Secure the seat belt mount in the B-pillar sill area.

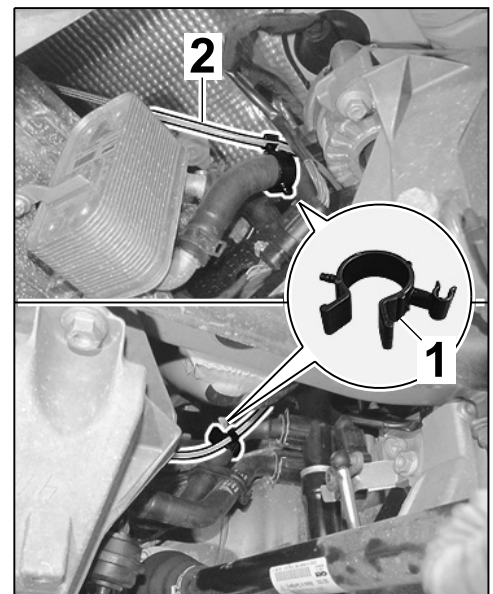

Figure 39

- 10.5.1 Guide the belt at the left of the door sill ⇒ *Figure 40-A-* and turn the seat belt mount 180 degrees (clockwise) ⇒ *Figure 40-B-*.

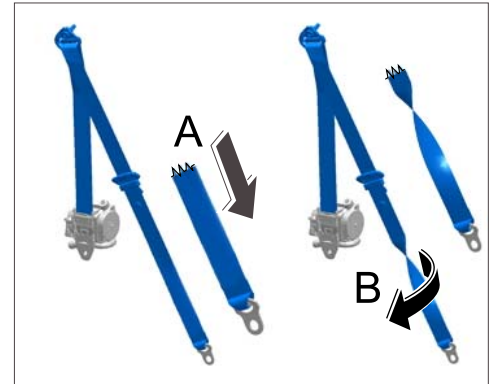

Figure 40

- 10.5.2 Guide cheese head bolt ⇒ *Figure 41-2-* through the seat belt mount ⇒ *Figure 41-3-* and spacer sleeve ⇒ *Figure 41-4-* and secure it.

**Tightening torque 50 Nm (37 ftlb.)**

- 10.5.3 Close the cap ⇒ *Figure 41-1-*.

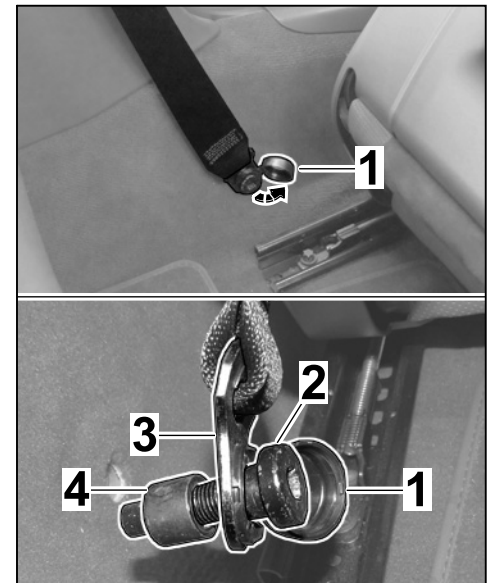

Figure 41

**WARNING**

**Incorrect handling of safety bolts**

- **Danger of injury**
  - **Loss of torque**
- ⇒ **Always use new fastening screws and nuts following removal.**
- ⇒ **Observe specified tightening torques.**
- ⇒ **Carry out a visual inspection of all re-used parts.**

- 10.6 Install left front seat. ⇒ *Workshop Manual '720119 Removing and installing front seat'*

- 10.7 Install inner door sill trim at the left. ⇒ *Workshop Manual '680519 Removing and installing inner door sill trim'*
- 10.8 Move convertible top out of service position. ⇒ *Workshop Manual '6101IN Convertible-top service position'*
- 10.9 Convert switch console.
- 10.9.1 Remove switch console. ⇒ *Workshop Manual '962719 Removing and installing switch console'*



### Information

The switch console consists of a total of 16 buttons, 10 light guides and 10 trims. Each half can be used for the left or right row of the main body.

- 10.9.2 Assemble new switch console in accordance with the new vehicle equipment.

Fit light guide at the correct side ⇒  
*Figure 42-1-* in the main body ⇒  
*Figure 42-arrow-*.

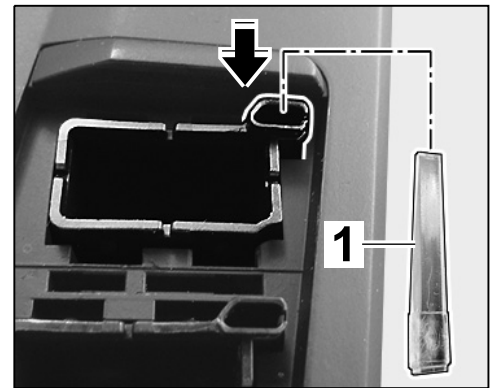

Figure 42

Fit trim ⇒ *Figure 43-1-* underneath  
the button in the main body ⇒  
*Figure 43-arrows-*.

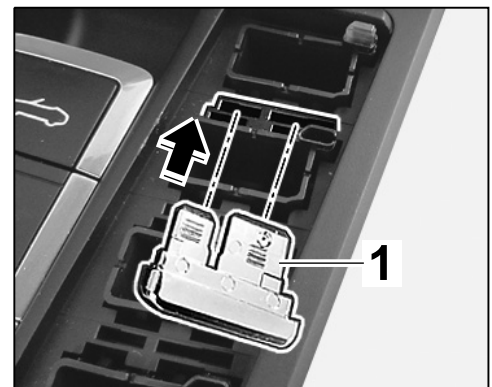

Figure 43

Position button ⇒ *Figure 44 -1-* and clip it into the main body ⇒ *Figure 44 -arrow-*.

10.9.3 Install switch console. ⇒ *Workshop Manual '962719 Removing and installing switch console'*

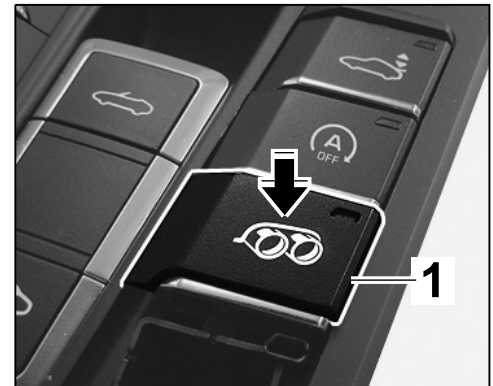

Figure 44

**NOTICE**

**Voltage drop**

- Risk of irreparable damage to control unit
  - Risk of damage to control unit
  - Fault entries in the control unit
  - Coding in the control unit is aborted
  - Malfunctions in control unit, even during programming
- ⇒ Switch off the ignition and remove the ignition key before disconnecting the control unit.
- ⇒ Ensure that the power supply is not interrupted during programming.
- ⇒ Connect a battery charger with a current rating of at least Nominal value 70 A to the vehicle battery.



**Information**

The **9818 - PIWIS Tester 2** instructions take precedence since the description may be different with later Tester releases.

The procedure described here has been structured in general terms; different text or additions may appear on the **9818 - PIWIS Tester 2**.

11 Code sports exhaust system.

11.1 **9818 - PIWIS Tester II** must now be connected and the ignition switched on.

11.2 Select the required vehicle type. PIWIS Tester Diagnostics starts.



**Information**

The sports exhaust system button can only be coded on the right-hand side of the switch console.

- 11.3 Code keypad assignment. ⇒ *Workshop Manual '962755 Replacing switch console'*
- 11.4 Maintenance of vehicle data
- 11.4.1 **Additional menu** must now be selected by pressing •F7" .
- 11.4.2 Select the **Maintenance of vehicle data** function. Press •F12" until **X numbers** appears in the Value group column.
- 11.4.3 Select **XLF - Sports exhaust system** in the Coding value column. When you touch the Installed cell, a tick appears.
- 11.4.4 Save the values by pressing •F8" . Wait until the message **Modified values have been buffered** appears.
- 11.4.5 Press •F12" until •F8" can be activated.
- 11.4.6 Press •F8" to write values. Wait until the message **Generation of vehicle data is complete** appears.
- 11.4.7 Press •F12" to switch to Report management. Open the log by pressing •F10" and check that vehicle equipment **XLF Sports exhaust system** is displayed.
- 11.5 Adapt coding.
- 11.5.1 Press •F11" to return to the list of control units.  
Select all control units.
- 11.5.2 Switch to the **Codings/adaptations** menu.  
Select **Automatic coding**. Press •F12" to continue.  
Wait until the message **Coding has been completed successfully** appears.  
Press •F12" to continue.
- 11.6 Read out the fault memories of all systems, work through any existing faults and erase the fault memories. ⇒ *Workshop Manual '033500 Fault memory for on-board diagnosis'*
- 11.7 Carry out "Sports exhaust system" function test.  
  
Start the vehicle. The exhaust flaps open when you press the "Twin tailpipe" button. The noise of the exhaust motor can be heard.
- 11.8 Disconnect battery charger. ⇒ *Workshop Manual '2X00IN Battery trickle charging'*

26013100: Sports exhaust system installed Labor time: **480 TU**  
Includes: Removing and installing rear mufflers and strip for switches,  
coding sports exhaust system.

**Important Notice:** Technical Bulletins issued by Porsche Cars North America, Inc. are intended only for use by professional automotive technicians who have attended Porsche service training courses. They are written to inform those technicians of conditions that may occur on some Porsche vehicles, or to provide information that could assist in the proper servicing of a vehicle. Porsche special tools may be necessary in order to perform certain operations identified in these bulletins. Use of tools and procedures other than those Porsche recommends in these bulletins may be detrimental to the safe operation of your vehicle, and may endanger the people working on it. Properly trained Porsche technicians have the equipment, tools, safety instructions, and know-how to do the job properly and safely. If a particular condition is described, do not assume that the bulletin applies to your vehicle, or that your vehicle will have that condition. See your authorized Porsche Dealer for the latest information about whether a particular technical bulletin applies to your vehicle. Part numbers listed in these bulletins are for reference only. Always check with your authorized Porsche dealer to verify the current and correct part numbers. The work procedures updated electronically in the Porsche PIWIS diagnostic and testing device take precedence and, in the event of a discrepancy, the work procedures in the PIWIS Tester are the ones that must be followed.

© Porsche Cars North America, Inc.

---

Dealership	Service Manager	_____	Shop Foreman	_____	Service Technician	_____	_____	_____	_____
Distribution									
Routing	Asst. Manager	_____	Warranty Admin.	_____	Service Technician	_____	_____	_____	_____

---

Dr. Ing. h.c. F. Porsche AG is the owner of numerous trademarks, both registered and unregistered, including without limitation the Porsche Crest®, Porsche®, Boxster®, Carrera®, Cayenne®, Cayman®, Macan®, Panamera®, Speedster®, Spyder®, 918 Spyder®, Tiptronic®, VarioCam®, PCM®, PDK®, 911®, RS®, 4S®, FOUR, UNCOMPROMISED®, and the model numbers and the distinctive shapes of the Porsche automobiles such as, the federally registered 911 and Boxster automobiles. The third party trademarks contained herein are the properties of their respective owners. Porsche Cars North America, Inc. believes the specifications to be correct at the time of printing. Specifications, performance standards, standard equipment, options, and other elements shown are subject to change without notice. Some options may be unavailable when a car is built. Some vehicles may be shown with non-U.S. equipment. The information contained herein is for internal authorized Porsche dealer use only and cannot be copied or distributed. Porsche recommends seat belt usage and observance of traffic laws at all times.

Printed in the USA