

Technical Bulletin

Model
911 Carrera 2
1990-92

Group
4

Subject: Tension Ring for Front Axle

Part Identifier
4057

Number
9306

ATTENTION: Service Manager/Service Technician

Models Affected: *911 Carrera 2 from 1990*
911 Turbo 1991 and 1992
911 America Roadster from 1992

Concern: To eliminate any confusion regarding the proper tension ring to be used on a specific model, this bulletin clarifies the ring application for each model listed above.

General Information: The following information will be divided into three sections: A, B and C. Each section will contain the necessary information to determine what tension ring is installed on a particular car and the applicable tightening torque for the front wheel hub nut.

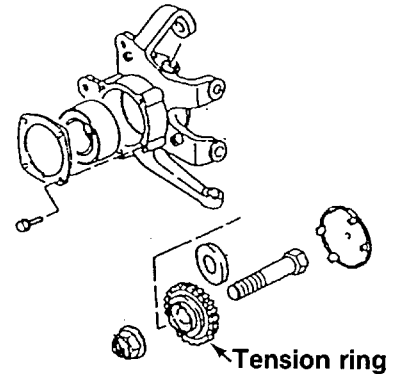

Figure 1

Figure 1 shows the location of the tension ring. Figure 2 shows the three variations of the tension ring as viewed from the side.

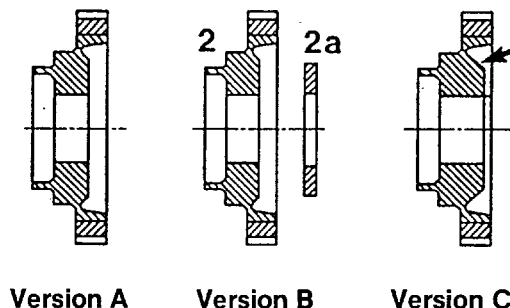
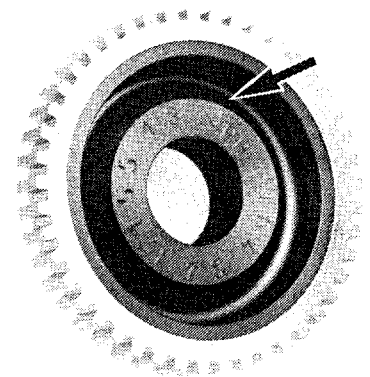

Figure 2



Version A:

911 C2/Turbo /America Roadster from production date November 28, 1991, from VIN:

- 960 NS 420564 Coupe
- 966 NS 440189 Targa
- 968 NS 460593 Cabriolet
- 1991 911 Turbo



Technical Bulletin

Model
911 Carrera 2
1990-92

Group
4

Subject: Tension Ring for Front Axle

Part Identifier
4057

Number
9306

The tightening torque for Version A tension ring is 420 Nm for Coupe, Targa and Cabriolet. For the 1991 911 Turbo and all Carrera 2 vehicles produced before November 28, 1991, the tightening torque for Version A tension ring is 460 Nm.

Version B:

911 C2 /America Roadster from production date April 1, 1992, from VIN:

966 NS 420701 Coupe
966 NS 440208 Targa
966 NS 460916 Cabriolet

The tightening torque for Version B tension ring is 460 Nm.

Note: The 4mm thick washer (2A) used in Version B is no longer available. Should replacement of this washer or the tension ring become necessary, then Version C tension ring is used. The 4mm washer **must not be used** with Version C.

Version C:

911 Turbo /America Roadster from production date July 7, 1992, from VIN:

967 NS 460990 America Roadster
963 NS 480308 Turbo

For Coupe and Targa 911 Carrera 2, there was no change. Once existing old stock (Version B tension ring) is depleted, then Version C will be used in production on Coupe and Targa models.

The tightening torque for Version C is 460 Nm.

Note: If replacement of the tension ring is necessary on any of the three versions, only Version C may be used. Different version tension rings may be mixed on one car.

Parts Information:

964 341 155 13 Tension Ring (Version C)

P
O
R
S
C
H
E
C
A
R
S
N
O
R
T
H
A
M
E
R
I
C
A
I
N
C

