

Technical Bulletin

Model
All 911
1994

Group
X

Subject: Motor Vehicle Theft Law
Enforcement Act - Part Marking

Part Identifier
N/A

Number
9301

ATTENTION: Service Manager/Service Technician

Models Affected: *All 1994 911 models
C2/C4/Turbo/Speedster*

**Concern and
General Information:**

In 1984, Congress passed an act which required that replacement and original parts of certain cars must be marked in a way that prevents "theft rings" from disposing of parts easily. Then in 1990, with the introduction of qualified alarm systems as standard equipment on all Porsche vehicles, Porsche vehicles were exempt from Parts Marking requirements.

With the re-introduction of the 911 Speedster, marking of parts, both original and replacement, will resume. This is necessary because the 1994 911 Speedster is not equipped with a central locking system.

I.D. Marking Locations:

The following diagrams show the location of I.D. marking locations for both original and replacement parts. The letter "O" will identify original I.D. location, "R" will identify replacement I.D. location.

The stickers that identify the part as original or replacement appear as below (see Figure 1).

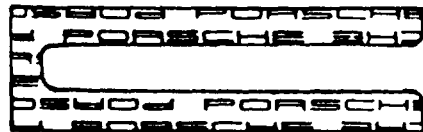

New Vehicle (Original Part)



Replacement Part

Figure 1

.....
Index # 039176
.....



Technical Bulletin

Model
All 911
1994

Group
X

Subject: Motor Vehicle Theft Law
Enforcement Act - Part Marking

Part Identifier
N/A

Number
9301

I.D. Marking Locations for Transmission and Engine

Tiptronic transmission original
(view from top)

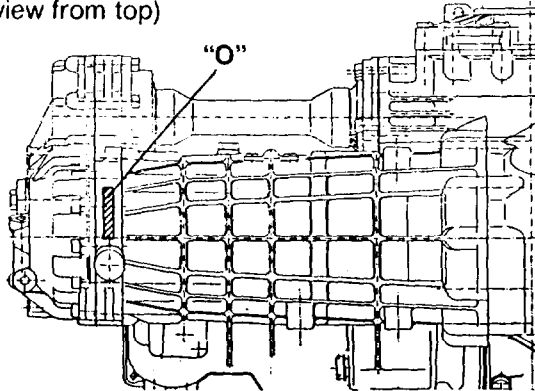

Tiptronic transmission replacement
(view from side)

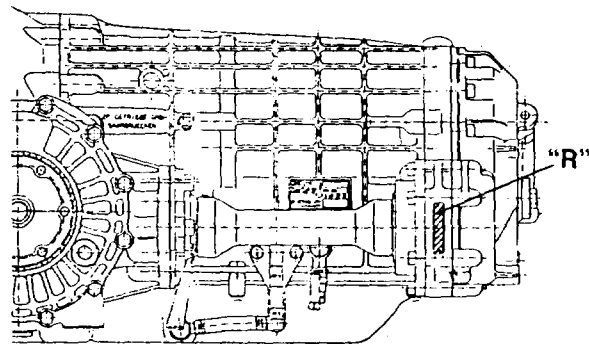

Manual transmission original
(bottom of transmission)

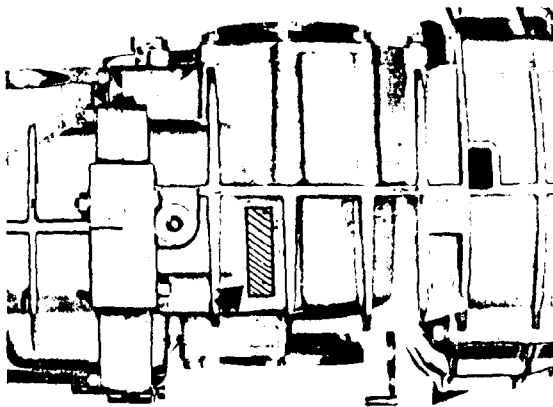

Manual transmission replacement
(top of transmission)

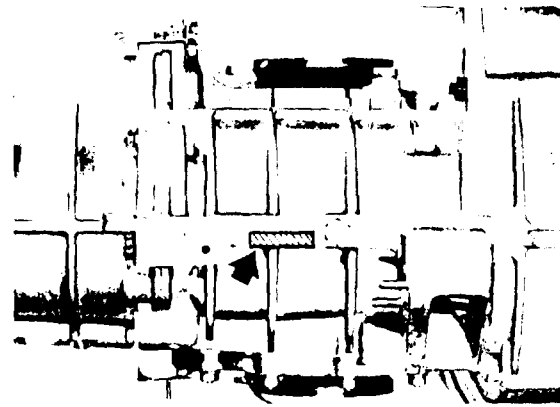

Engine original
(bottom of engine)



Engine replacement
(bottom of engine)



PORSCHE CARS NORTH AMERICA INC.



Technical Bulletin

Model
All 911
1994

Group
X

Subject: Motor Vehicle Theft Law
Enforcement Act - Part Marking

Part Identifier
N/A

Number
9301

I.D. Marking Locations for Body Parts

Door
(left and right)

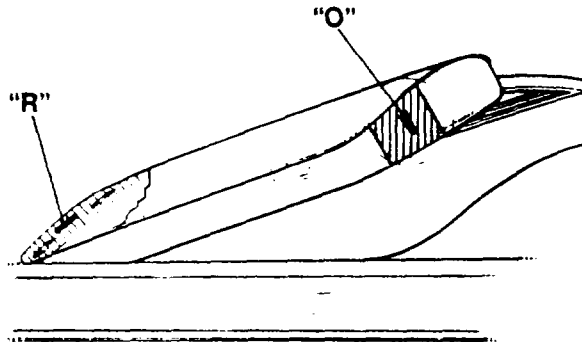

(viewed from below)

Front bumper

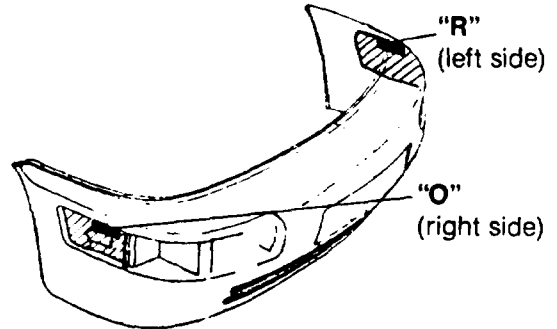

Fender front
(left and right)
Rear top inside fender seam

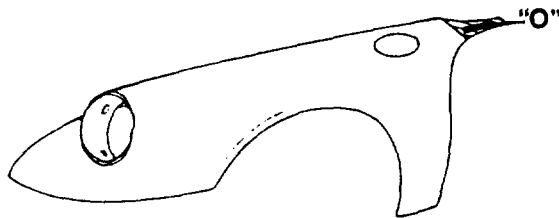

Fender front
(left and right)
Mounting flange rear inside

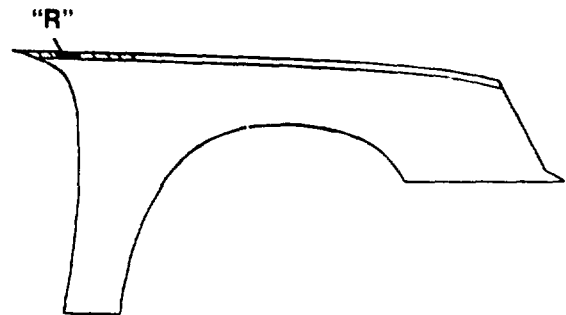

Bumper rear
(in 3 parts)

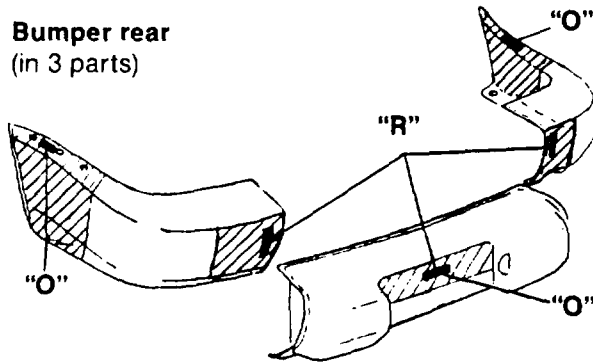

Note: On the center section of the rear bumper, the original I.D. marking is behind the license plate bracket. On the replacement part, it is on the inside behind the insulation piece.

PORSCHE CARS NORTH AMERICA INC.



Technical Bulletin

Model
All 911
1994

Group
X

Subject: Motor Vehicle Theft Law
Enforcement Act - Part Marking

Part Identifier
N/A

Number
9301

I.D. Marking Location for Body Parts

Front hood

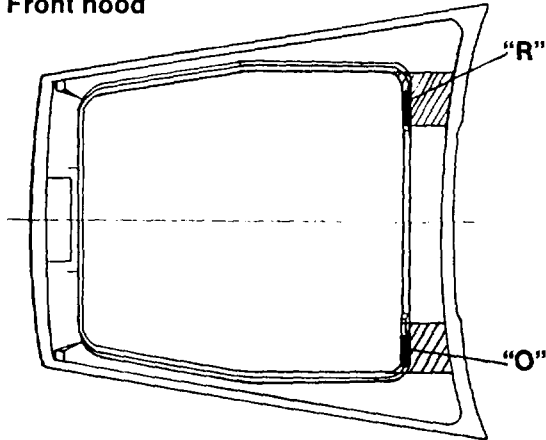

Engine lid

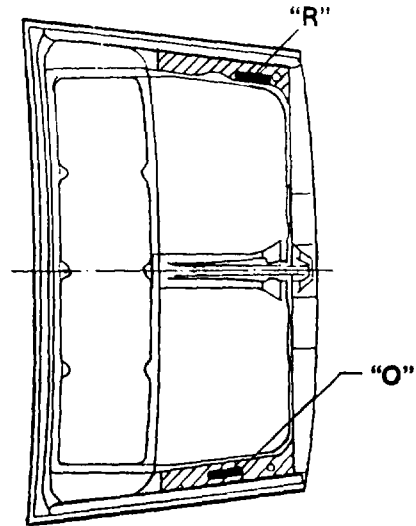

Rear quarter panel
(left and right)

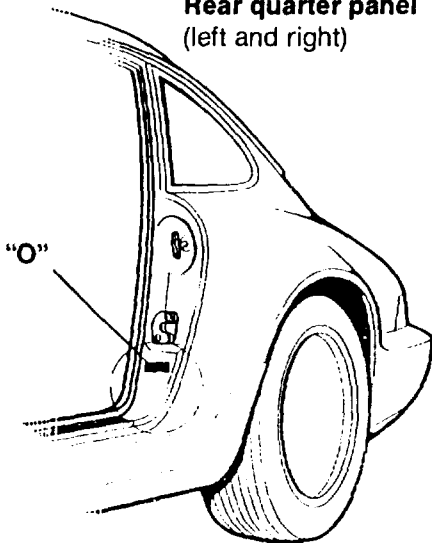

Rear quarter panel
(left and right)
Inside engine lid opening

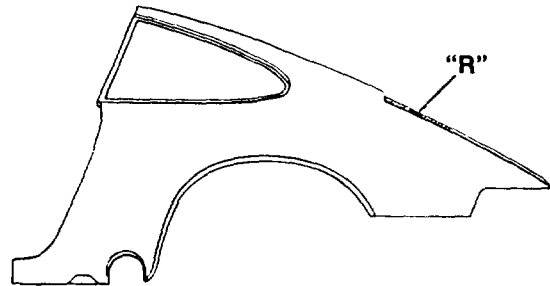

PORSCHE CARS NORTH AMERICA INC.

