

Code 30103202	Type VA01-AP90/VLL-66A Suction/Puller	Fan Diameter 305 mm
-------------------------	---	-------------------------------

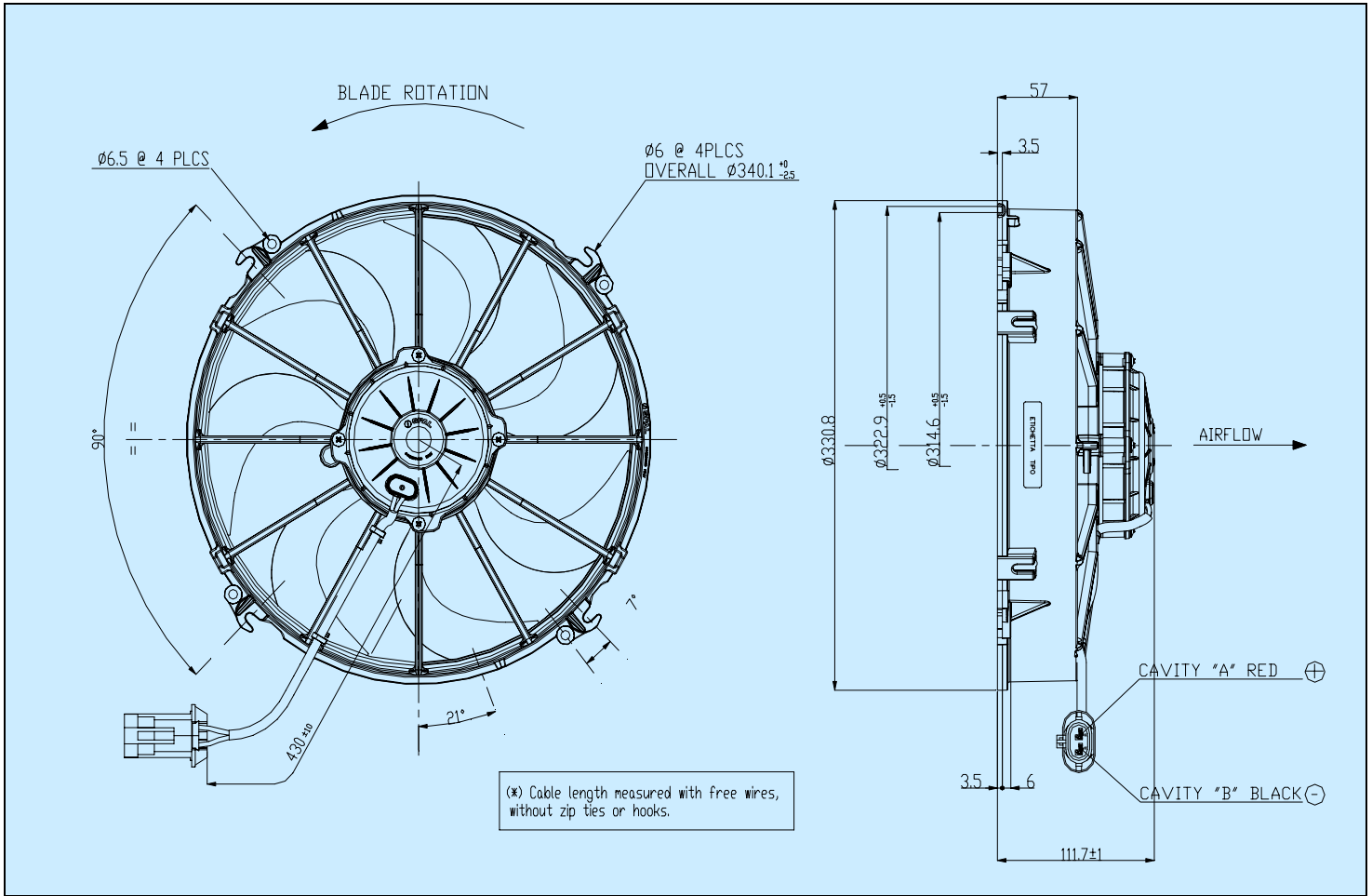

Test Voltage @ 13VDC

Approximate Weight is 5.5lbs.

Waterproof motor (IP68)

Very Long Life Motor

Delphi/Packard 630 Series
Connector Interface

Static Pressure Mm H2O	Airflow m ³ /h	Current Amps
0	3073	22.1
2.6	2940	23.2
5	2801	23.7
7.6	2655	23.8
10	2482	24.9
12.4	2414	25.5
15	2265	25.8
17.4	2138	26.3
20.1	1900	26.4
22.5	1788	26.3
25.1	1539	26.1
27.4	1018	27.1
30	783	28.6
32.6	615	29.1
35	528	29.7
37.4	466	30.1
39.9	308	31.3
42.5	183	32.9
45	0	33.3

ISOMETRIC (ENLARGED) VIEWS

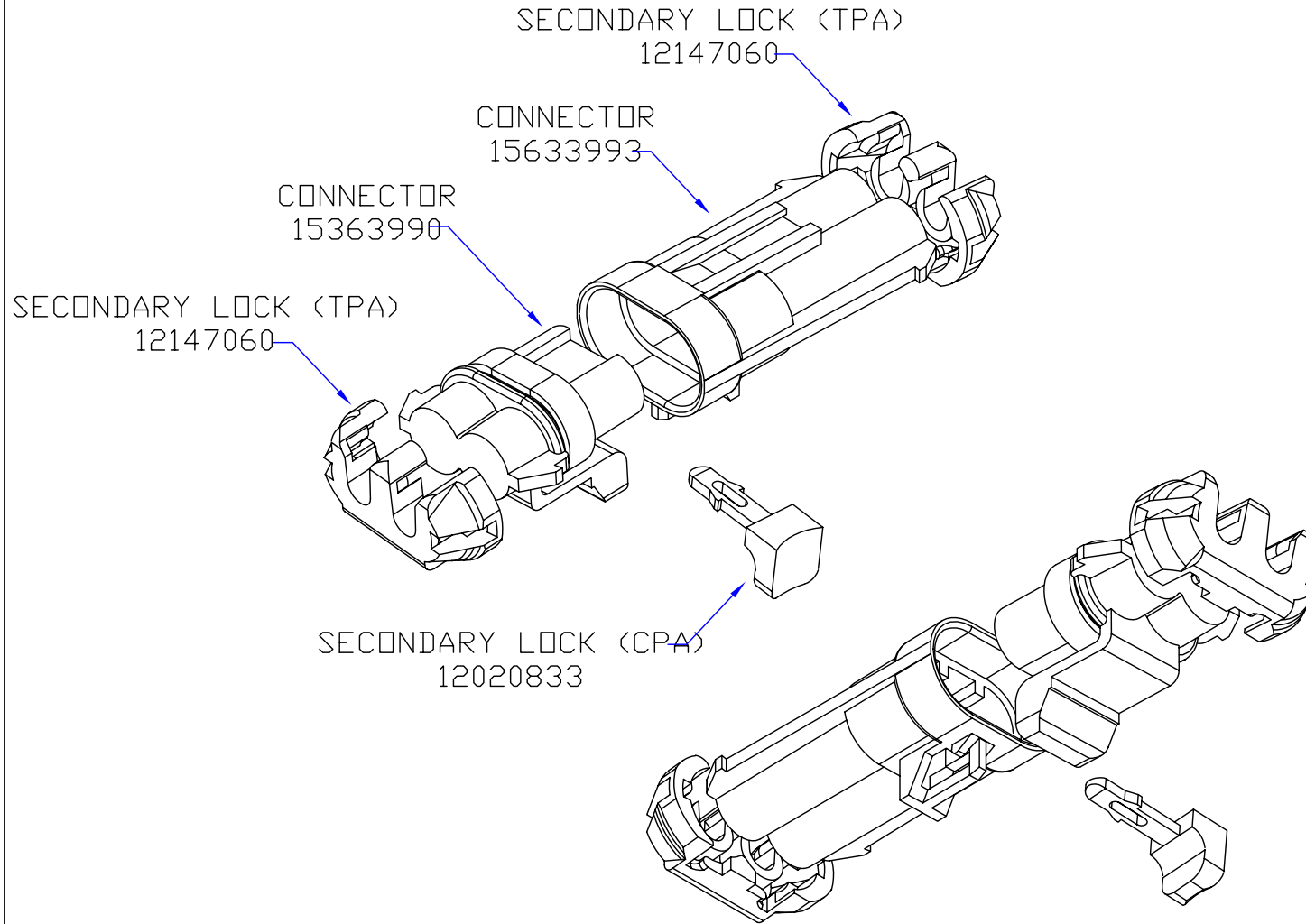

NOTES:

1. SECONDARY LOCK 12147060 (TPA) INSTALLED ON CONNECTOR 15363990 AS SHOWN UPON SUCCESSFUL INSERTION/INDEXING OF CORRESPONDING WIRES.
2. OPTIONAL - SECONDARY LOCK 12020883 (CPA) INSERTED INTO LATCHING MECHANISM OF CONNECTOR 15363990 PRIOR TO SHIPPING. THIS CPA WILL BE REMOVED AT THE TIME OF INSTALLATION OF THE HARNESS IN APPLICATION. HARNESS CONNECTOR 15363990 IS MATED TO FAN CONNECTOR 15363993. THE CPA IS INSERTED INTO THE COMBINED LATCHED MECHANISM OF THE 2 CONNECTORS TOGETHER.