

first time fit

A/C Compressor Assembly Installation Instructions

Prior to the installation of this DENSO *First Time Fit* A/C compressor kit, you must read these instructions completely.

Definition of Terms

△WARNING: Describes precautions that should be observed in order to prevent injury or death to the user during installation.

△CAUTION: Describes precautions that should be observed in order to prevent damage to the vehicle or its components, which may occur during installation if sufficient care is not taken.

NOTE: Provides additional information that facilitates installation work.

WARRANTY

NOTE: Information relating to maintaining the DENSO *First Time Fit* A/C compressor warranty.

General Service Information and Requirements

△CAUTION: Only trained/certified personnel who have a thorough knowledge of automotive air conditioning systems should perform repairs to the air conditioning system.

△WARNING: It has been determined that mixtures of R-134a and air can result in combustion when exposed to a spark. Shop air should not be used for leak checking since it contains moisture and can be combustible when used with R-134a.

REQUIRED TOOLS:

- Safety Goggles
- Assorted Hand Tools
- Refrigerant Recovery Machine for specific (R-12/R-134a) refrigerant
- Charging Station / A/C Manifold Gauge Set for specific (R-12/R-134a) refrigerant
- Vacuum Pump for specific (R-12/R-134a) refrigerant
- Electronic Leak Detector
- Torque Wrench
- Belt Tension Gauge
- Magnetic Clutch Pressure Plate Remover

SAFETY PRECAUTIONS

⚠WARNING: DENSO compressors are sealed, pressurized and contain factory-specified amounts of refrigerant oil used in the original design of the unit. PRIOR to removal of shipping plates or unit installation, you must read these instructions completely.

- Always wear safety goggles.
- Avoid skin contact with refrigerant or refrigerant oil.
- Work in a well-ventilated area.
- Never release refrigerant into the atmosphere.
- Never expose refrigerant container to direct heat or temperature in excess of 125°F.
- Never expose refrigerant to an open flame.

NOTE: Service valve(s) are not included with this compressor. Reuse service valve(s) from compressor being replaced (if applicable). Do not attempt removal or reinstallation of service valve(s) before reading instructions.

Compressor type identification can be found on the rear housing which is opposite of the magnetic clutch.

Compressor Removal Procedures

NOTE: Before removal of the compressor, please refer to the appropriate manufacturer's service manual for complete instructions.

1. Disconnect negative (-) ground cable from battery.
2. Disconnect A/C compressor lead wire from the vehicle harness.
3. Using a certified refrigerant recovery machine, reclaim the old refrigerant from the A/C system.
4. Disconnect the suction and discharge hoses from the compressor and quickly cap the hose ends to reduce the amount of moisture entering the A/C system.
5. Loosen and remove the compressor drive belt.
6. Remove compressor mounting bolts and remove compressor.

Service Valve Installation

NOTE: Not all DENSO compressors require the service valve(s) to be reused. If the compressor type does not use a separate service valve(s), it is **mandatory** to still verify the level of compressor lubricant. (See Fig. 1)

1. Slowly release the pressure from the Schrader valve located on the compressor shipping plate(s).
2. To prevent the loss of refrigerant oil, place the compressor on a flat surface with the shipping plate(s) in an upright position, then remove and save the shipping plate(s), O-ring(s) and mounting bolts.
3. Remove the service valve(s) from the old compressor. Make sure service valves and O-ring surfaces are clean.
4. Verify the level of compressor lubricant. (See Fig. 1)
5. Remove new O-ring(s) from plastic bag (included with compressor) and install O-ring(s) in grooves in compressor. (See Fig. 2)
6. Lubricate new O-ring(s) with appropriate DENSO lubricant to ensure proper seating of O-ring(s).

7. Attach service valve(s) or service valve cap(s) to compressor using original bolts and torque bolts to 24.5 N·m (250 kgf·cm, 18.1 lbf·ft). (See Fig. 3)
8. Attach shipping plate with O-ring(s) or service valve cap(s) to old compressor to prevent oil leakage/damage to compressor during shipment.

WARRANTY NOTE: Item 8 is mandatory for core acceptance.

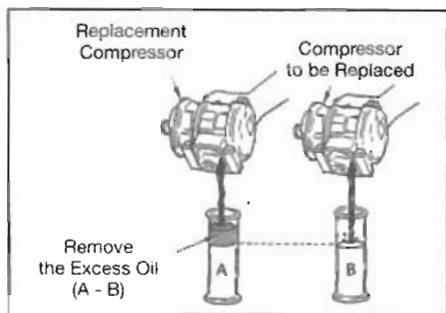

Fig. 1

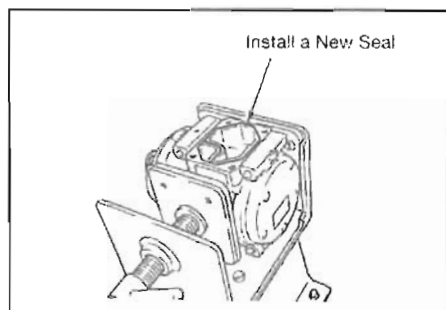

Fig. 2

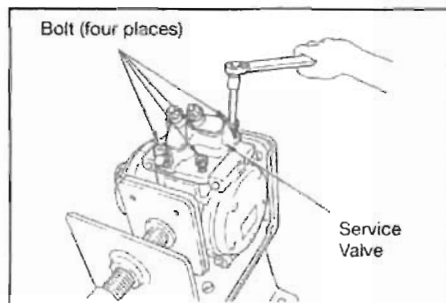

Fig. 3

Compressor Installation

NOTE: Before installing the compressor, please refer to the appropriate manufacturer's service manual for complete instructions.

1. Install the magnetic clutch to the compressor. *(If applicable, refer to A/C Compressor Magnetic Clutch Installation Instructions)*
2. Place the compressor on a flat surface with the service valve(s) in an upright position, hand turn the clutch pressure plate a minimum of 10 times to release lubricant from the compressor head.
3. Install the compressor to the engine and/or engine bracket, tighten and torque the bolts to factory specifications. Refer to appropriate manufacturer's service manual for correct bolt tightening sequence and torque.
4. Install compressor drive belt on compressor and tighten to factory specifications. Refer to appropriate manufacturer's service manual for correct bolt tightening sequence and torque.
5. Using the appropriate compressor oil, lubricate and install new O-ring(s) to the suction and discharge hoses. Connect and torque the hoses to compressor.
6. Connect A/C compressor lead wire to vehicle harness.
7. To insure system performance and protection, always install a new receiver drier or accumulator when replacing the compressor.

WARRANTY NOTE: Receiver drier or accumulator replacement is mandatory as a condition for warranty acceptance.

8. Connect negative (-) ground cable to battery.
9. Evacuate and recharge A/C system.
 - Protect eyes and skin during recharging by using safety glasses and appropriate handwear.
 - Connect manifold gauge set & vacuum pump/refrigerant charging station and evacuate A/C system for a minimum of 30 minutes at 61-69 cmHG (24-27 inHG) of vacuum.
 - Charge the A/C system with refrigerant per the factory specifications.
 - Use the appropriate electronic leak detector to check the compressor and hose connections for leaks.
 - DO NOT overcharge the A/C system.

TORQUE SPECIFICATIONS

| Lines Fittings | TYPE / REFRIGERANT | TYPE / REFRIGERANT | TYPE / REFRIGERANT |
|-------------------|-----------------------------------|-------------------------------------|-----------------------------------|
| | Flare Nut / R-12 | Block / R-12 | Block Type / R-134a |
| Suction | 32.5 N·m 332 kgf·cm, 24 lbf·ft | 24.5 N·m 250 kgf·cm, 18.1 lbf·ft | 9.8 N·m 100 kfg·cm, 7.2 lbf·ft |
| Discharge | 21.7 N·m 225 kgf·cm, 16 lbf·ft | 24.5 N·m 250 kgf·cm, 18.1 lbf·ft | 9.8 N·m 100 kfg·cm, 7.2 lbf·ft |

Compressor Oil Type

Compressor oil is necessary for the lubrication of the compressor bearings, moving and sliding parts. Since compressor oil circulates through the entire refrigeration cycle, manufacturer's recommended oil must be used. The recommended oil for crankshaft and swash plate type compressors using refrigerant R-12 is ND-OIL 6.

"Through vane" (TV) type compressors use a completely different oil. The recommended oil for TV type compressors using refrigerant R-12 is ND-OIL 7. ND-OIL 7 is manufactured with special additives to endure the TV compressor design vane clearances. Using substitutes or mixtures with other oils must be avoided because this could lead to vane seizure.

The composition of refrigerant R-134a prevents the use of conventional mineral oils used with R-12. The new R-134a systems use a synthetic lubricant, polyalkylene glycol or (PAG) oil. ND-OIL 8 is used for swash plate type and ND-OIL 9 is used for TV type compressors using refrigerant R-134a.

When the compressor is replaced, the amount of oil needed for the system is filled in the DENSO compressor. Therefore, when replacing the compressor remove excess oil as outlined in the "Service Valve Installation" instructions.

COMPRESSOR OIL ID CHART

| Refrigerant Compressor | R-134a (HFC 134a) | R-12 (CFC 12) |
|------------------------------|----------------------|------------------|
| Reciprocating Swash Plate | ND-OIL 8 | ND-OIL 6 |
| Rotary Through Vane | ND-OIL 9 | ND-OIL 7 |