



FUEL INJECTORS AND ADAPTERS

HIGH-FLOW RATE FUEL INJECTOR SETS

PCM calibration data for each model of injector is available on our website.

PART NUMBER (SETS OF 8)	FLOW RATE	BODY STYLE	IMPEDANCE	LENGTH	CONNECTOR
M-9593-C302*	19 lb/hr	EV1	11-18 ohms	L	Jetronic/Minitimer
M-9593-M23*	23 lb/hr	EV6	11-18 ohms	L	USCAR
M-9593-AA302* 	24 lb/hr	EV6	11-18 ohms	L	Jetronic/Minitimer
M-9593-BB302* 	30 lb/hr	EV6	11-18 ohms	L	Jetronic/Minitimer
M-9593-MU32* 	32 lb/hr	EV14	11-12 ohms	M	USCAR
M-9593-M39*	39 lb/hr	EV6	11-18 ohms	L	USCAR
M-9593-F302*	42 lb/hr	EV1	11-18 ohms	L	Jetronic/Minitimer
M-9593-G302*	47 lb/hr	EV14	11-18 ohms	M	USCAR
M-9593-LU60*	60 lb/hr	EV6	11-12 ohms	L	USCAR

All injector flow rates are quoted at a delta pressure of 39.15 psi. To convert to a delta pressure of 43.5 psi, multiply flow rate by 1.054.

INJECTOR ADAPTER KITS

M-14464-A8*

- Adapts Jetronic/Minitimer style harness to USCAR style injector
- Packaged in sets of (8)



M-14464-A8 shown

INJECTOR ADAPTER KITS

M-14464-U2J

- Adapts USCAR style harness to Jetronic/Minitimer style injector
- Packaged in sets of (8)



BODY STYLE



EV1



EV6



EV14

CONNECTORS



Jetronic/
Minitimer



USCAR

LENGTH

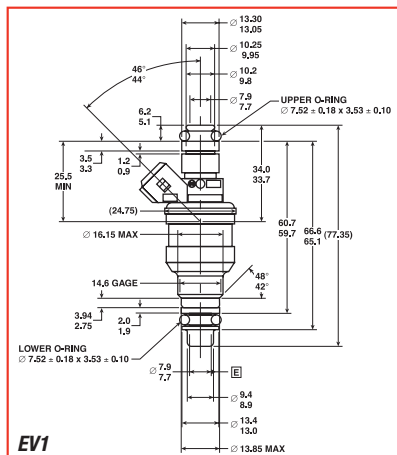

EV1

Long

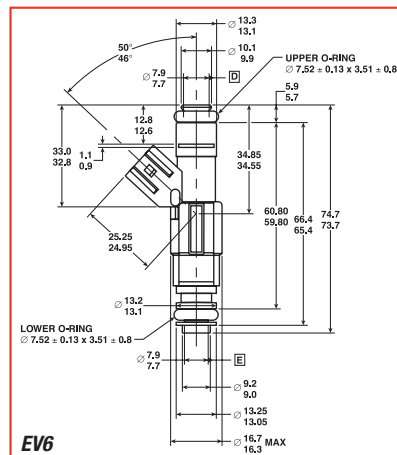

EV6

Long

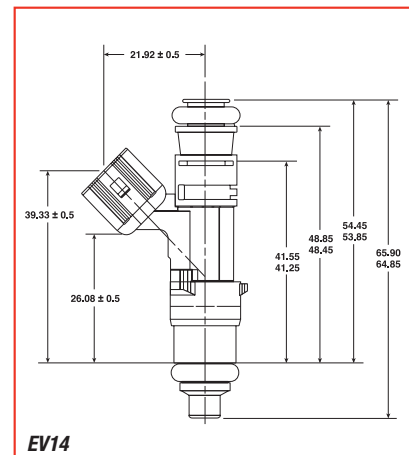

EV14

Medium

PROPERLY SELECTING ELECTRONIC FUEL INJECTION COMPONENTS

One of the more commonly misunderstood aspects of Electronic Fuel Injection (EFI) is how to select the correct size fuel injectors, fuel pump and Mass Air Flow (MAF) sensor for a particular engine horsepower output. The following information is intended to offer a very brief tutorial on properly selecting the most common EFI components.

FUEL INJECTORS

First and foremost, adding larger fuel injectors alone will NOT create extra horsepower! The purchase of larger fuel injectors should only be considered when your engine has exceeded the horsepower capacity of the existing fuel injectors, at which point larger injectors are then required to SUPPORT the additional horsepower. If you add larger-than-stock injectors to an otherwise stock engine, you should not expect any horsepower increase whatsoever.



The nominal injection pressure for most Ford EFI systems is 39.15 psi (270 kPa) “across the injector.” The term “across the injector” takes manifold pressure and fuel rail pressure into account, and is usually referred to as “delta pressure.” (See “Measuring Fuel Pressure” below for more details.) Ford Racing’s fuel injectors are always rated at 39.15 psi delta, so the fuel injector sizing discussions found below will assume a fuel pressure of at least 39.15 psi delta.

There are some exceptions to the above-mentioned nominal injection pressure. In relatively recent years, emissions regulations have become so stringent that the government is now regulating the emissions output that gasoline vehicles are allowed to produce even when the engine is not running! This is referred to as “evaporative emissions” and results from unburned hydrocarbons (raw fuel) emitting into the atmosphere from the fuel tank, fuel lines, injector leakage, intake manifold, etc. when the engine is shut off. This is the fundamental purpose of the charcoal canister (and hydrocarbon trap in the air-box on many vehicles) and is also the reason that Ford switched to the Returnless Fuel Systems (RFS) found in production vehicles today. These systems have only a fuel supply line from the tank to the engine, with no return line. The primary reason for these systems is that evaporative emissions increase as the temperature of the fuel in the tank increases. On a conventional return system, the fuel is sent to the engine through the supply line, and the excess is returned (via the mechanical fuel pressure regulator) to the tank through the return line. Since the engine is hot, this process heats up the fuel and thus increases evaporative emissions. To combat this, the returnless fuel systems were invented. Currently, Ford uses 2 primary types of RFS which are called Electronic Returnless Fuel System (ERFS) and Mechanical Returnless Fuel System (MRFS). The latter is the simpler of the two systems and controls the fuel rail to a constant pressure via a regulator in the tank, which is typically set to around 60 psi. The powertrain control module (PCM) then calculates the pressure across the injector either by inferring or measuring manifold pressure and subtracting from what it knows is the rail pressure set-point. ERFS, on the other hand, has no mechanical regulator at all, but instead has a Fuel Rail Pressure Transducer (FRPT) mounted on the fuel rail that measures fuel rail pressure relative to manifold pressure and feeds that information back to the PCM. The PCM then controls the Fuel Pump Driver Module (FPDM) which in turn varies the voltage to the fuel pump (or pumps) in the tank to supply the correct pressure and flow rate to the injectors. Most of the time this pressure is maintained at 39.15 psi delta, but when the fuel temperature rises, this pressure can be boosted in order to delay the onset of boiling the fuel. Some vehicles also boost the pressure under some conditions in order to get away with using smaller flow-rate fuel injectors for various reasons beyond the scope of this tutorial. Both V6 and V8 Mustangs have used ERFS since the 1999 model year and continue to do so today. The purpose of going into all this detail is to convey the message that if you choose your fuel injectors based on a pressure of 39.15 psi delta (which is the pressure at which Ford Racing specifies the flow rate), the injectors will be correctly sized regardless of which fuel system you actually have, and also to show you that fuel pressure on ERFS vehicles can change based on a number of conditions. These concepts will be important in the rest of this tutorial.

If you are trying to compare injector flow rates and you have flow data at one delta pressure, you can easily calculate the flow rate at a different delta pressure as follows:

Flow rate at new delta pressure = (flow rate at old pressure) x $\sqrt{\text{new pressure/old pressure}}$

Example: What is the flow rate for an injector at 43.5 psi if it is rated at 60 lb/hr at 39.15 psi?

Flow rate at 43.5 psi delta = $60 \times \sqrt{43.5/39.15} = 63.2 \text{ lb/hr}$

You can use the following information to properly determine what size injectors are needed for various applications. For this example, we will use a naturally aspirated 5.0L V8 engine making 300 hp. Keep in mind that this is FLYWHEEL (also known as brake) horsepower, NOT wheel horsepower.

Engines require a certain fuel flow rate that is generally measured in lb/hr (pounds per hour) and can be calculated via knowledge of their Brake Specific Fuel Consumption (BSFC). By definition, BSFC represents how much fuel (in lb) is required per hour per each brake horsepower the engine produces. Most naturally aspirated production gasoline engines generally operate on a 0.42 to 0.52 lb/hp-hr BSFC at wide open throttle (WOT). High-performance gasoline and race engines (12.5:1 compression ratio and higher) which tend to be extremely efficient can sometimes have a BSFC as low as 0.38 to 0.42. More clearly stated, this means that if you have a gasoline engine that makes 300 brake horsepower, its total maximum fuel requirement in lb/hr can be calculated as follows:

Fuel flow requirement = (brake horsepower) x (BSFC)

Example: A 300 hp naturally aspirated gasoline-powered V8 requires what size fuel injector?

First, assume a BSFC of 0.50 lb/hr and injection pressure of 39.15 psi across the injector.

$300 \text{ hp} \times 0.50 \text{ lb/hp-hr} = 150 \text{ lb/hr}$ maximum total fuel flow requirement

Since this is the total fuel flow requirement to the engine, we must now divide this by the number of injectors being used to determine the flow rate necessary for each injector so that you can select the correct size injector from this catalog. In this example, we have an 8-cylinder engine using 1 injector per cylinder, which gives: **150 lb/hr/8 injectors = 18.8 lb/hr per cylinder**

PROPERLY SELECTING ELECTRONIC FUEL INJECTION COMPONENTS (continued...)

So, technically, the engine only needs a 19 lb/hr fuel injector to support 300 hp, but this will require that the injector is at nearly a 100% duty cycle in order to achieve this horsepower level. Duty cycle refers to how long the injector needs to be open (flowing fuel) in order to supply the required amount of fuel. If the injector needs a 100% duty cycle at a particular engine speed and load to inject enough fuel, that means it is open all the time. Under most conditions, fuel is injected when the intake valves are closed, which helps with fuel atomization and efficiency. If the injectors need to be on 100% of the time to supply enough fuel, this means that some fuel is being injected while the intake valves are open. Depending on the overlap of the cam in the engine, some of this unburned fuel can be blown right past the exhaust valve, or be poorly atomized, which makes for a less efficient combustion process. Perhaps more importantly, operating a fuel injector between roughly 85% and 99% duty cycle does not give the injector sufficient time to close before it is commanded to open again. This can cause extreme variability in the amount of fuel actually injected, which can sometimes result in a rich condition. Similar issues exist at the low end of the flow region at extremely low duty cycles, but this is highly dependent on the type and flow rate of each model of injector. In this case the injector does not have enough time to fully open before it is commanded to close again, which causes extreme variability that can result in a lean condition. For these reasons, we generally recommended selecting an injector with a flow rate sufficiently high that it will not be required to exceed an 85% duty cycle. So to figure out what size fuel injector will result in an 85% duty cycle, divide the original result by 0.85: $18.75 \text{ lb/hr} / 0.85 = 22.1 \text{ lb/hr requirement}$.

Since the next popular injector size available is 24 lb/hr, this is the correct size injector that you should choose for this particular application. Keep in mind that this discussion assumes your fuel pump, lines, regulator, etc. are sufficient to be able to maintain at least 39.15 psi across the injector at all engine speeds and loads (even under boost, if applicable). Now that you have selected an injector, the calibration (or "tune") in the PCM must either be changed or a different MAF must be used. (See "Mass Airflow Sensors" below for more details.)

This calculation can also be reversed to give the maximum safe hp a set of injectors can support, which gives:

$$\text{max safe hp} = [(\text{injector size}) \times (\text{total \# of injectors}) \times (\text{max duty cycle})] / \text{BSFC}$$

Example: The following guide is a general rule of thumb for sizing fuel injectors on an **8-cylinder engine** using a BSFC of 0.50. Forced-induction engines typically range from a BSFC of 0.55 to 0.65, with the latter value arising from the fuel enrichment necessary to keep exhaust temperatures below 1650 deg F and catalyst temperatures below 1700 deg F.

Naturally Aspirated: $(19 \text{ lb} \times 8 \times .85) / .50 = 258.4$ or approx 258 hp @ 85% duty cycle
 Forced Induction @ 0.55: $(19 \text{ lb} \times 8 \times .85) / .55 = 234.9$ or approx 235 hp @ 85% duty cycle
 Forced Induction @ 0.65: $(19 \text{ lb} \times 8 \times .85) / .65 = 198.8$ or approx 199 hp @ 85% duty cycle

Inj Flow Rate (@ 40 psid)

19 lb/hr
 24 lb/hr
 30 lb/hr
 32 lb/hr
 39 lb/hr
 42 lb/hr
 47 lb/hr
 60 lb/hr

Naturally Aspirated hp (@ 0.50)

258 hp @ 85% Duty Cycle
 326 hp @ 85% Duty Cycle
 408 hp @ 85% Duty Cycle
 435 hp @ 85% Duty Cycle
 530 hp @ 85% Duty Cycle
 571 hp @ 85% Duty Cycle
 639 hp @ 85% Duty Cycle
 816 hp @ 85% Duty Cycle

Forced-Induction hp (@ 0.65)

199 hp @ 85% Duty Cycle
 251 hp @ 85% Duty Cycle
 314 hp @ 85% Duty Cycle
 335 hp @ 85% Duty Cycle
 408 hp @ 85% Duty Cycle
 439 hp @ 85% Duty Cycle
 492 hp @ 85% Duty Cycle
 628 hp @ 85% Duty Cycle

Remember, the above calculations assume a fuel pressure of 39.15 psid. If you can raise fuel pressure and still be sure that your fuel pump can supply the desired flow rate, then these maximum horsepower numbers will increase.

FUEL PUMPS

Most EFI fuel pumps are rated for flow at 12 volts @ 40 psi. Most vehicle charging systems operate anywhere from 13.2 V to 14.4 V. Within limits, the more voltage you feed a pump (for a given current), the faster it spins, resulting in a higher output of fuel from the same fuel pump. Rating a fuel pump at 12 V should offer a fairly conservative fuel flow rating allowing you to safely determine the pump's ability to supply an adequate amount of fuel for a particular application, assuming the gauge of wire feeding power to the pump is sufficient to carry the current required.



As previously mentioned, engines actually require a certain **mass** of fuel, NOT a certain **volume** of fuel per hour per horsepower. This can offer a bit of confusion since most fuel pumps are rated by volume, and not by mass. To determine the proper fuel pump required, a few mathematical conversions will need to be performed using the following information. There are 3.785 liters in 1 U.S. gallon and 1 gallon of gasoline (0.72 specific gravity @ 65° F) weighs 6.009 lb.

An additional fact to consider regarding the BSFC is that the specific gravity of the fuel that you are using is very important. The fuel that you put in your car should only be obtained from a source which supplies fuel intended for an automobile. Some people make the mistake of using aviation fuel (sometimes referred to as "Av Gas") thinking that the higher octane of this fuel may offer a performance gain. The problem is that TRUE aviation fuel has a much lower specific gravity (commonly as low as 0.62 to 0.65) than automotive grade fuel (0.72 to 0.76). Herein lies the problem: as previously stated, an engine requires a certain **mass** of fuel per hour per horsepower, and 1 gallon of aviation gasoline has a lower mass than 1 gallon of automotive gasoline. Since the specific gravity of aviation gasoline is only about 90% that of automotive gasoline, all other things being equal, your engine will run approximately 10% lean by using aviation gasoline. Be sure to take the specific gravity and stoichiometric ratio of your desired fuel into consideration when sizing the fuel pump and injectors.

PROPERLY SELECTING ELECTRONIC FUEL INJECTION COMPONENTS (continued...)

It is always a good idea to apply a safety factor to account for things such as pump-to-pump variability, voltage loss between the pump and the battery, etc., so we recommend you multiply the final output of the fuel pump by 0.90 to determine the capacity of the fuel pump at 90% output to be on the safe side.

To determine the overall capacity of a fuel pump rated in liters per hour (L/hr), use the following additional conversions:

<i>Do:</i>	<i>To Get:</i>
(L/hr)/3.785	→ U.S. gallons/hr
Multiply above by 6.009 lb/gallon	→ lb/hr
Multiply above by 0.9	→ Capacity in lb/hr at 90%
Divide above by BSFC	→ "Horsepower Capacity" (flywheel)

So for a fuel pump rated at 110 L/hr for example, supplying a naturally aspirated engine:

110/3.785	= 29.06 U.S. gallons/hr
29.06 x 6.009	= 174.62 lb/hr
174.62 x 0.9	= 157 lb/hr @ 90% capacity
157/0.50	= 314 hp safe naturally aspirated "Horsepower Capacity"

Safe "Horsepower Capacity" @ 40 psi with 12 V assuming 0.5 lb/hp-hr BSFC

60 L/hr pump	= 95 lb/hr X 0.90	= 86 lb/hr, safe for up to 170 naturally aspirated flywheel hp
88 L/hr pump	= 140 lb/hr X 0.90	= 126 lb/hr, safe for up to 250 naturally aspirated flywheel hp
110 L/hr pump	= 175 lb/hr X 0.90	= 157 lb/hr, safe for up to 310 naturally aspirated flywheel hp
155 L/hr pump	= 246 lb/hr X 0.90	= 221 lb/hr, safe for up to 440 naturally aspirated flywheel hp
190 L/hr pump	= 302 lb/hr X 0.90	= 271 lb/hr, safe for up to 540 naturally aspirated flywheel hp
255 L/hr pump	= 405 lb/hr X 0.90	= 364 lb/hr, safe for up to 720 naturally aspirated flywheel hp

Very Important Note: For any type of forced-induction engine, the above maximum power levels will be reduced because as the boost pressure increases, the fuel pressure required from the pump also increases, creating an additional load to the fuel pump, which results in a decreased fuel flow rate at the higher pressure. In order to do proper fuel pump sizing for these applications, a fuel pump map is required, which shows flow rate versus delivery pressure for a given voltage. For example, a 255 L/hr pump at 40 psi may only supply 200 L/hr at 58 psi (40 psi plus 18 lb of boost). Additionally, if you use a fuel supply line that is not large enough, this can result in decreased fuel flow due to the pressure drop. For example, a 255 L/hr at the pump may only result in 220 L/hr at the fuel rail because as the required pressure increases (due to the pressure loss from the supply line restriction), the maximum flow rate of the pump decreases. Figure 1 shows an example fuel pump map for a pump assembly at a supply voltage of 13 V.

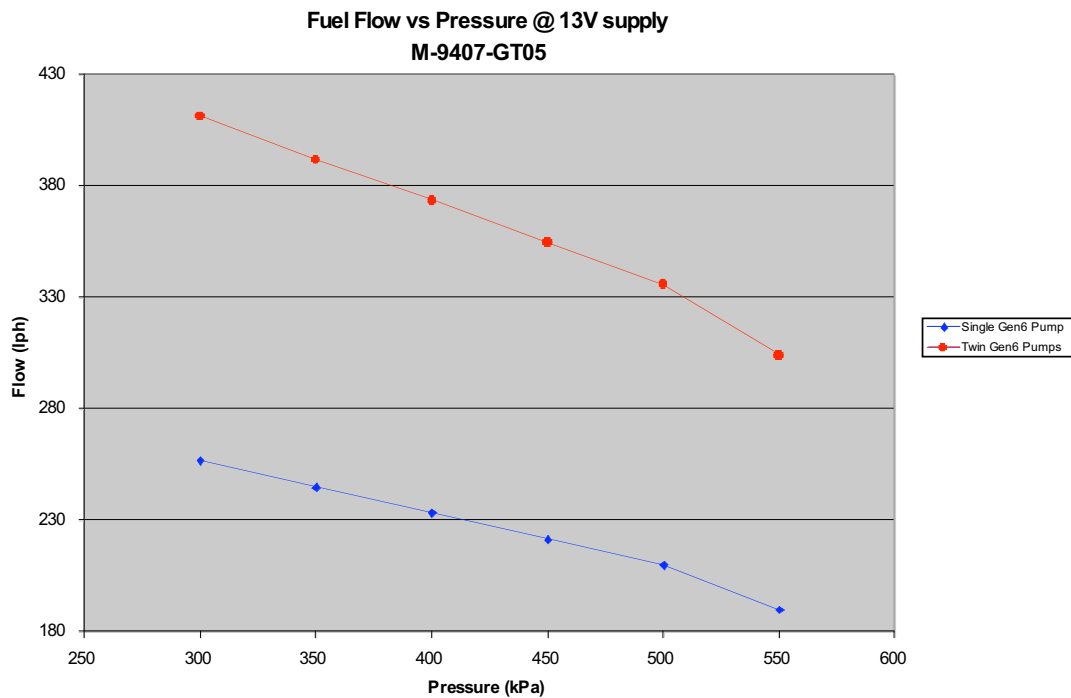

Figure 1

MEASURING FUEL PRESSURE

The above fuel pump sizing information should be regarded as a **guideline** in selecting the size of pump you need. Once installed in the car, you still need to **verify** that adequate fuel pressure (at least 39.15 psi across the injector) is maintained at all engine speeds and loads. Do not skip this fuel pressure verification step, as failure to maintain adequate fuel pressure can cause issues ranging from calibration difficulty to engine failure due to running lean.

PROPERLY SELECTING ELECTRONIC FUEL INJECTION COMPONENTS (continued...)



As mentioned earlier, all injector flow rates published in this catalog have been determined at a pressure of 39.15 psi (270 kPa) across the injector, but what does the phrase “across the injector” mean? To understand this fully, we first need to discuss three different methods of measuring pressure.

The first is called **absolute** pressure. This is defined as the pressure relative to a complete vacuum, such as would be found in outer space. For instance, atmospheric pressure (the air we breathe) is typically around 14.7 psi absolute (29.93 inHg) at sea level, depending on temperature and weather conditions. An engine that has a vacuum signal of 12 “inches” simply means that the absolute pressure in the intake manifold is 12 inHg less than the atmospheric pressure. When you subtract the 12 inHg from the atmospheric pressure of 29.93 inHg, you are left with a positive pressure of 17.93 inHg, or roughly 9 psi absolute as compared to a complete vacuum. Sometimes you will see absolute pressure in psi written as “psia.”

The second is called **gauge** pressure, which is pressure relative to atmospheric pressure. Gauge pressure is what everyone is most familiar with because it is what you measure when you check the air in your tires or when you connect a fuel pressure gauge to the fuel rail. An engine which makes 6 psi of boost at sea level is actually equivalent to 20.7 psi absolute ($14.7 + 6 = 20.7$). Sometimes you will see gauge pressure in psi written as “psig.”

The third is called **delta** pressure and is very much like gauge pressure, but instead of being relative to atmospheric, it can be relative to any other pressure, such as the pressure in the intake manifold. Sometimes you will see delta pressure in psi written as “psid.”

When we quote pressure “across the injector,” what we really mean is the **delta** pressure (or difference) between the fuel rail and the intake manifold. On most EFI systems (non-MRFS), this is the pressure that the system controls, either by use of a mechanical regulator referenced to the intake manifold (in a traditional or “return” system), or by the use of the FRPT and the PCM (in ERFS). This means that if you connect a fuel rail pressure gauge to the fuel rail on one of these systems, you will see fuel pressure vary depending on intake manifold pressure. This is because the gauge is measuring gauge pressure, which is relative to atmospheric, but the EFI system is controlling the fuel rail pressure relative to intake manifold pressure which is changing depending on engine load (your right foot) among other things. On a naturally aspirated engine, the manifold pressure at idle is typically around 10 psia, and the manifold pressure at Wide Open Throttle (WOT) will be atmospheric, so typically at the fuel rail you will see approximately 30 psig at idle and at least 39.15 psig at WOT, depending on whether or not you have ERFS and whether or not it is boosting pressure for one of the reasons mentioned in the previous section. On a forced-induction engine, the highest manifold pressure that the engine can reach will be atmospheric *plus* the maximum boost your configuration can obtain. This means that to keep 39.15 psid across the injector, the gauge pressure will have to increase by the same amount as the maximum boost. A couple of examples should make these concepts more clear. First, consider a naturally aspirated conventional (non-ERFS, non-MRFS) EFI system with a mechanical regulator set at the stock pressure setting. The system will try to keep the pressure across the injector at 39.15 psid regardless of engine load, so if you have a fuel pressure gauge attached to the fuel rail, you will see a maximum pressure of 39.15 psig at WOT if the system is doing its job properly. Now consider a forced-induction engine making a maximum of 10 psig boost, also with a conventional EFI system and mechanical regulator set to the stock pressure setting. The system will still try to keep the pressure across the injector at 39.15 psi, so this time your fuel pressure gauge attached to the rail should read a maximum of $39.15 + 10 = 49.15$ psig. If it never gets to 49.15 psig at WOT, your fuel system is inadequate for your engine. You will need to either increase the capacity of the pump, minimize the voltage loss between the pump and the battery or decrease the pressure loss between the pump and the engine through the use of larger lines, etc., and re-test. Do NOT try to “tune around” this type of fuel delivery problem. It will bite you in the long run, and can result in hard-to-diagnose problems at best, all the way to engine failure at worst. Note that at WOT, the fuel pump in the forced-induction engine must supply fuel at a higher pressure than in the naturally aspirated engine. As mentioned in the previous section, this means that the fuel pump supplying the forced-induction engine will have a lower maximum flow rate capability than the fuel pump supplying the naturally aspirated engine. This is a critical concept to grasp because it means that in general, **for engines with equal brake horsepower, the fuel pump supplying the forced-induction engine will need to have more capacity than the fuel pump supplying the naturally aspirated engine!**

MASS AIRFLOW SENSORS

On EFI systems that use a MAF sensor, this is the single most important sensor on the engine for determining a proper air/fuel (A/F) ratio. Unfortunately, it is also one of the most misunderstood sensors on the engine as well. The engine’s air/fuel ratio and spark advance are determined by the PCM primarily from the input received from the MAF sensor. This is also why it is of critical importance that there are no air leaks (defined as air entering the intake stream between the MAF and the combustion chamber) in a MAF-based system. Air leaks can cause a check-engine light, rough idling, stalling, spark knock, drivability issues and, in extreme cases, complete engine failure, depending on their magnitude.

PROPERLY SELECTING ELECTRONIC FUEL INJECTION COMPONENTS (continued...)



As with fuel injectors, changing the MAF alone will not result in more horsepower on an otherwise stock engine. A different MAF sensor should only be considered after engine modification which either causes the stock sensor to become a flow restriction or when the stock MAF sensor electronics are insufficient to measure the airflow that the modified engine is capable of ingesting. This latter point is critical in understanding when a MAF needs to be replaced. It is possible to have 2 MAF sensors that are equal in size, but capable of different maximum power levels. This is because the electronics in each MAF are different and are capable of measuring different maximum airflow, despite the fact that the size of the MAF housing is the same. For example, you can have 2 different 90 mm MAF sensors but one will be capable of measuring 60 lb/min of air, while the other can measure, say, 100 lb/min of air. They both present the same airflow restriction (which is dictated primarily by their physical size) but they are definitely NOT interchangeable. So how do you know how much air your MAF needs to be capable of measuring? If you have an approximation of the engine's BSFC at WOT, as well as a target air/fuel ratio in mind, then the amount of air that your MAF sensor needs to be capable of measuring (in lb/hr) can be calculated as follows. Note that this formula includes a safety factor of 10%.

$$\text{Max airflow} = 1.10 * (\text{Power} * \text{BSFC} * \text{A/F Ratio})$$

Example: What is the max airflow a naturally aspirated 300 hp gasoline engine will ingest?

First, assume a BSFC of 0.50 lb/hp-hr and A/F ratio of 12:1.

$$\text{Max airflow} = 1.1 * (300 * 0.50 * 12) = \mathbf{1980 \text{ lb/hr}}$$

Now that we know the minimum size fuel injector and MAF that we need, we have to consider what the PCM will do with this new hardware. The two main methods of dealing with the installation of a new MAF and injectors are to either "trick" the PCM by careful selection of injectors and a "matched" MAF, or by changing the calibration in the PCM to match the MAF and injectors that you selected.

The first method requires a MAF sensor that has been "curved" to a certain flow rate of injector. For instance, let's say your engine originally came with 19 lb/hr injectors and you replaced them with 39 lb/hr injectors. To use this method, you will need a MAF with electronics that have been modified such that it will output a signal proportional to an airflow that is 19/39 times as great as the stock MAF would measure. This will result in the PCM delivering the correct amount of fuel despite the fact that the injector size has been increased from 19 lb/hr to 39 lb/hr. The downside of this method is that many other variables such as spark advance are determined from the MAF sensor through a parameter called "load." For a given engine rpm, as load increases, required spark advance decreases. Since, by using this method, the MAF outputs a signal that is lower than the stock MAF, the calculated load will also be lower. This means that commanded spark advance will be higher than it should be, which can potentially result in spark knock, and other concerns. While this method works quite well on less sophisticated electronics, such as the EEC-IV found in Fox body Mustangs, it is not recommended for newer vehicles which have a much higher dependency on the calculated value of load.

The second, and preferred method requires the ability to alter the calibration inside the PCM, generally through the use of one of the aftermarket tools available. When using this method, the actual flow data for the injector (available on our website for all FRPP injectors), as well as the "transfer function" for the MAF are entered into the calibration in the PCM. Generally, it is recommended to test the new calibration on a dynamometer to ensure that the engine receives the correct A/F ratio at all speeds and loads. Provided this is performed by a competent and experienced tuner using proper equipment, this is by far the best method and will result in the best part-throttle drivability and idle, and the least amount of trouble with check-engine lights, returnless fuel, electronic throttle monitors, transmission shifting, etc.

Prior to tuning on a dyno, you should be absolutely certain that the ground circuits for the EFI system are in pristine condition. Doing so will help to ensure that the calibration you and your tuner develop on the dyno will also work when you leave. It can't be overstated that prior to the vehicle being tuned in any way, all vacuum leaks, electrical issues, etc., need to be resolved. Fixing them before you go to the dyno will always be cheaper than paying for dyno time while you're wrenching on your car.

As a *general rule of thumb*, the following stock Ford MAF sensors will safely support the corresponding horsepower:

MAF Sensor	Approximate Max hp
55 mm (Stock 88-93 Mustang)	275 hp
70 mm (Stock 94-95 Mustang)	350 hp
80 mm (Stock Ford)	425 hp
90 mm (M-12579-54)	540 hp

If you have a specific question not addressed in this tutorial, please contact the Ford Racing technical hotline at 1-800-FORD788 and we will be happy to assist you.