

Throttle-valve angular-position sensors

Measurement of angles up to 92°

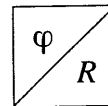

- Potentiometric angular-position sensor with linear characteristic curve
- Sturdy construction for extreme loading
- Very compact

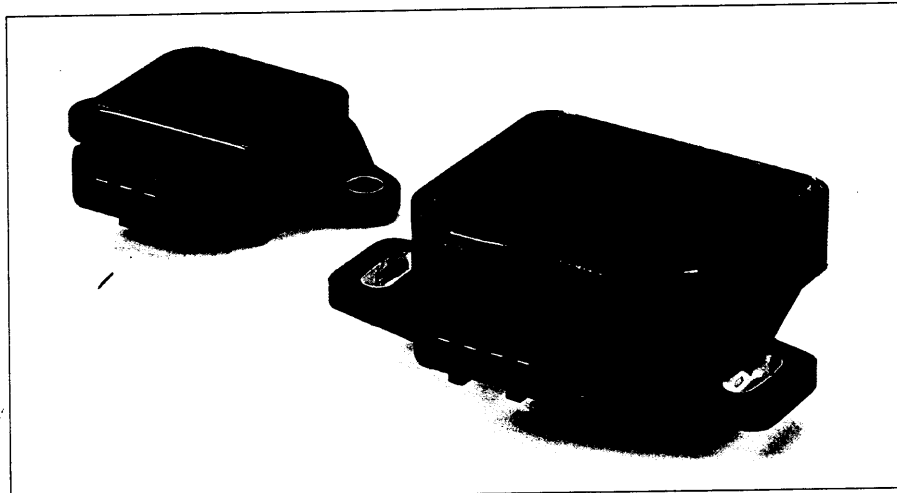

Application

These sensors are used in automotive applications for measuring the angle of rotation of the throttle valve. Since these sensors are directly attached to the throttle-valve housing at the end of the throttle-shaft extension, they are subject to extremely hostile underhood operating conditions. In order to remain fully functional under such conditions, they must be resistant to fuels, oils, saline fog, and industrial climate.

Design and function

The throttle-valve angular-position sensor is a potentiometric sensor with a linear characteristic curve. In electronic fuel-injection (EFI) engines, it serves to generate a voltage ratio which is proportional to the throttle valve's angle of rotation. The sensor's rotor is attached to the throttle-valve shaft, and when the throttle valve moves, the sensor's special wipers travel over the corresponding resistance tracks so that the throttle's angular position is transformed into an equivalent voltage ratio.

Design

The throttle-valve angular-position sensor 0 280 122 001 has one linear characteristic curve. The throttle-valve angular-position sensor 0 280 122 201 has two linear characteristic curves. This permits a very high resolution in the angle range 0°...23°.

Explanation of symbols

U_A Output voltage
 U_V Supply voltage
 φ Angle of rotation
 U_{A2} Output voltage, characteristic curve 2
 U_{A3} Output voltage, characteristic curve 3

Accessories for 0 280 122 001

Connector 1 237 000 039

Accessories for 0 280 122 201

Cable terminal 1 284 485 118
 Receptacles, 5 per pack
 Qty. required: 4 1 284 477 121
 Protective cap, 5 per pack
 Qty. required: 1 1 280 703 023

Characteristic curve 1

A Internal stop, L Positional tolerance of wiper when sensor installed, N Nominal characteristic curve, T Tolerance limits, φ_w Useful electrical angular range.

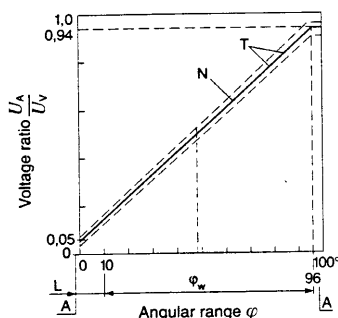

Characteristic curve 2 and 3

A Internal stop, φ_w Useful electrical angular range.

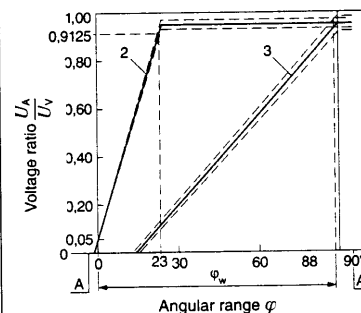

Technical Data / Range

	0 280 122 001 ¹⁾	0 280 122 201
Part number	1.2	3
Diagram	≤ 86	≤ 88
Useful electrical angular range	Degrees	≤ 88
Useful mechanical angular range	Degrees	≤ 92
Total electrical angular range	Degrees	≤ 96
Angle between internal stops (not to be reached when sensor installed on engine)	Degrees	≥ 98
Direction of rotation	Arbitrary	Arbitrary
Total resistance (Terms. 1-2)	kΩ	2 ± 20 %
Wiper protective resistor (wiper in zero position, Terms 2-3)	Ω	710 ... 1380
Operating voltage U_V	V	5
Electrical loading		Ohmic Ohmic
Permissible wiper current	μA	≤ 18
Voltage ratio from stop to stop		
Characteristic curve 1	0.04 ≤ U_A/U_V ≤ 0.96	
Voltage ratio in the range 0 °C ... 88 °C		
Characteristic curve 2	-	0.05 ≤ U_{A2}/U_V ≤ 0.985
Characteristic curve 3	-	0.05 ≤ U_{A3}/U_V ≤ 0.970
Slope of the nominal characteristic curve	grd ⁻¹	0.00927
Operating temperature	°C	-30 ... +110
Short-term	°C	-40 ... +120
Guide values for permissible vibration acceleration	m · s ⁻²	≤ 700
Service life (operating cycles)	Mio	2

¹⁾ This version has one linear characteristic curve

Dimension drawings

A Plug-in connection C 280 202 294 A/3-pole

B O-ring 14.65x2,

C Fixing dimensions for throttle-valve housing, D Clockwise¹⁾,

E Counterclockwise¹⁾, Ö Opening direction of the throttle valve.

¹⁾ Throttle valve in idle position

0 280 122 001

F O-ring 16.5x2.5, G 2 ribs, 2.5 mm thick,

H Plug-in connection C 280 202 294 A, I Blade terminal,

K Fixing dimensions for throttle-valve potentiometer,

L This mounting position is only permissible when the throttle-valve shaft is sealed against oil and gasoline etc. Ö Opening direction of the throttle valve.

0 280 122 001

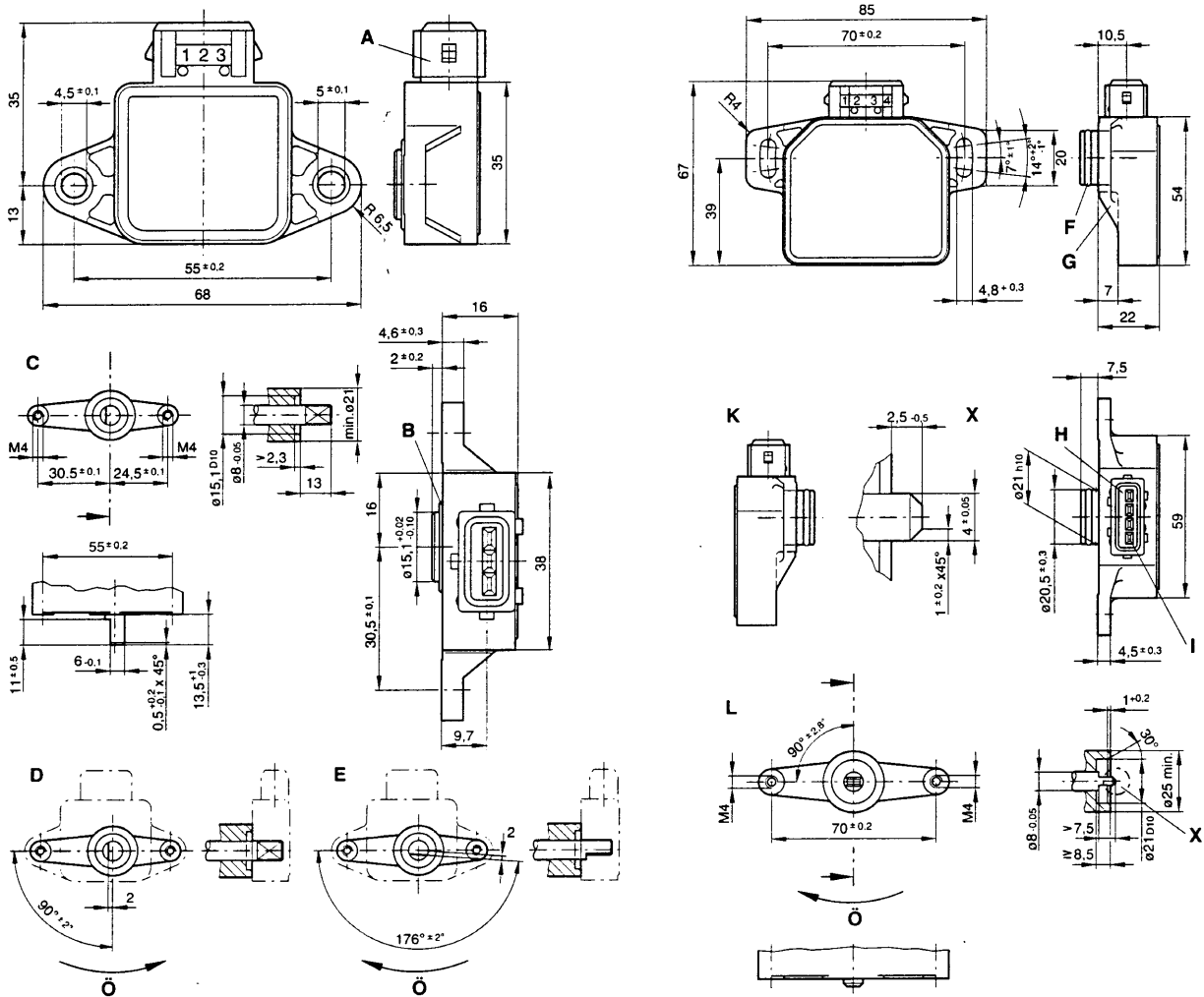

Diagram 1

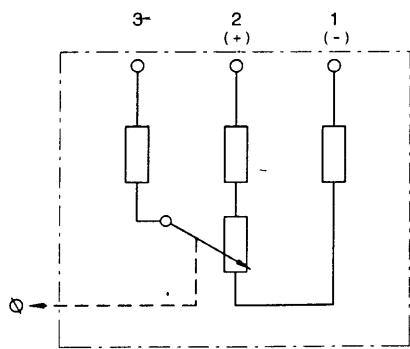

Diagram 2

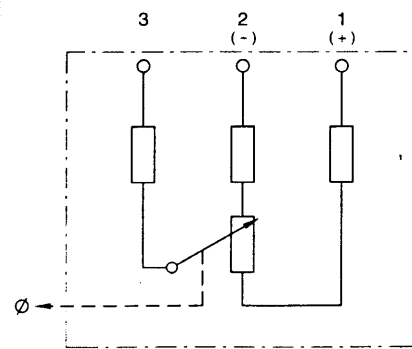

Diagram 3

(throttle valve in idle position)

